

z/OS Communications Server



# CSM Guide

*Version 2 Release 1*

**Note:**

Before using this information and the product it supports, be sure to read the general information under “Notices” on page 115.

**First edition (September 2013)**

This edition applies to version 2, release 1, modification 0 of z/OS (5650-ZOS), and to subsequent releases and modifications until otherwise indicated in new editions.

IBM welcomes your comments. You may send your comments to the following address.

International Business Machines Corporation  
Attn: z/OS Communications Server Information Development  
Department AKCA, Building 501  
P.O. Box 12195, 3039 Cornwallis Road  
Research Triangle Park, North Carolina 27709-2195

You can send us comments electronically by using one of the following methods:

**Fax (USA and Canada):**

1+919-254-1258

Send the fax to “Attn: z/OS Communications Server Information Development”

**Internet email:**

comsvrcf@us.ibm.com

**World Wide Web:**

<http://www.ibm.com/systems/z/os/zos/webqs.html>

If you would like a reply, be sure to include your name, address, telephone number, or FAX number. Make sure to include the following information in your comment or note:

- Title and order number of this document
- Page number or topic related to your comment

When you send information to IBM, you grant IBM a nonexclusive right to use or distribute the information in any way it believes appropriate without incurring any obligation to you.

© Copyright IBM Corporation 2000, 2013.

US Government Users Restricted Rights – Use, duplication or disclosure restricted by GSA ADP Schedule Contract with IBM Corp.

---

# Contents

<b>Figures</b> . . . . .	<b>v</b>
<b>Tables</b> . . . . .	<b>vii</b>
<b>About this document</b> . . . . .	<b>ix</b>
Who should read this document . . . . .	ix
How this document is organized . . . . .	ix
How to use this document . . . . .	ix
Determining whether a publication is current . . . . .	ix
How to contact IBM service . . . . .	x
Conventions and terminology that are used in this document . . . . .	x
How to read a syntax diagram . . . . .	xi
Prerequisite and related information . . . . .	xiii
<b>Summary of changes</b> . . . . .	<b>xix</b>
<b>Chapter 1. Communications storage manager (CSM) overview</b> . . . . .	<b>1</b>
CSM application programming interface (API) . . . . .	1
Installing, defining, and initializing CSM . . . . .	2
Monitoring CSM storage . . . . .	2
Diagnosing CSM problems . . . . .	4
Formatting CSM dump information . . . . .	5
Application responsibilities for using CSM . . . . .	5
Functions provided by the CSM API . . . . .	6
Creating and registering buffer pools . . . . .	8
Requesting storage from CSM . . . . .	9
CSM buffer lists . . . . .	9
Fixed buffers versus pageable buffers . . . . .	10
Ownership of buffers . . . . .	10
Storage return . . . . .	12
Clearing data from buffers . . . . .	12
Removing registration from a pool . . . . .	13
Copying data to or from a CSM buffer . . . . .	13
Sharing buffers among multiple users . . . . .	14
Obtaining CSM dumping information . . . . .	15
Obtaining CSM resource statistics . . . . .	16
CSM buffer pool expansion and contraction . . . . .	17
Buffer return exit routine . . . . .	18
CSM recovery for normal and abnormal termination . . . . .	19
<b>Chapter 2. CSM macroinstructions</b> . . . . .	<b>21</b>
How the macroinstructions are described . . . . .	21
Computing environment for the CSM API . . . . .	22
IVTCSM REQUEST=ASSIGN_BUFFER . . . . .	23
IVTCSM REQUEST=CHANGE_OWNER . . . . .	29
IVTCSM REQUEST=COPY_DATA . . . . .	34
IVTCSM REQUEST=CREATE_POOL . . . . .	40
IVTCSM REQUEST=DELETE_POOL . . . . .	46
IVTCSM REQUEST=DUMP_INFO . . . . .	49
IVTCSM REQUEST=FIX_BUFFER . . . . .	52
IVTCSM REQUEST=FREE_BUFFER . . . . .	56
IVTCSM REQUEST=GET_BUFFER . . . . .	61
IVTCSM REQUEST=PAGE_BUFFER . . . . .	68
IVTCSM REQUEST=RESOURCE_STATS . . . . .	73

<b>Appendix A. IVTCSM macroinstruction return and reason codes . . . . .</b>	<b>77</b>
<b>Appendix B. CSM DSECTs . . . . .</b>	<b>81</b>
CSM buffer list entry (IVTBUFL) . . . . .	81
CSM data space information (IVTDATSP) . . . . .	83
CSM resource status area (IVTSTATA) . . . . .	83
<b>Appendix C. Related protocol specifications . . . . .</b>	<b>85</b>
<b>Appendix D. Architectural specifications. . . . .</b>	<b>109</b>
<b>Appendix E. Accessibility . . . . .</b>	<b>111</b>
<b>Notices . . . . .</b>	<b>115</b>
Programming interface information . . . . .	123
Policy for unsupported hardware. . . . .	123
Trademarks . . . . .	123
<b>Bibliography. . . . .</b>	<b>125</b>
<b>Index . . . . .</b>	<b>129</b>
<b>Communicating your comments to IBM . . . . .</b>	<b>133</b>

---

## Figures

1. Example of copy data buffer list and copy results. . . . . 14



---

## Tables

1.	Buffer pools in CSM . . . . .	1
2.	Valid operands for IVTCSM macroinstruction . . . . .	7
3.	Default values for EXPBUF . . . . .	42
4.	Default values for INITBUF . . . . .	43
5.	Default values for MINFREE. . . . .	44
6.	IVTCSM macroinstruction return and reason codes . . . . .	77
7.	CSM buffer list format . . . . .	81
8.	IVTDATSP DSECT layout. . . . .	83





---

## About this document

This document helps customers write application programs that use the communications storage manager (CSM). It describes the CSM application programming interface (API). It also describes the IVTCSM macro and the programming techniques for using this macro. It is intended to be used by application programs using the high performance data transfer (HPDT) interface. See the *z/OS Communications Server: SNA Programmer's LU 6.2 Guide* for information about how VTAM® application programs use the HPDT interface.

---

## Who should read this document

This book is for system programmers who code authorized application programs for a System/390® or zSeries® host. This audience can include programmers who are modifying existing programs or writing new ones. The manual can also be useful to planners who are estimating the amount of work required to use the API for CSM.

You should be familiar with programming concepts and programming VTAM applications, as described in *z/OS Communications Server: SNA Programming*, before you use the macroinstructions described in this book.

You should be familiar with the following concepts:

- Systems network architecture
- Data communications
- LU 6.2 architecture

---

## How this document is organized

This document is divided into the following sections:

- Chapter 1, "Communications storage manager (CSM) overview," on page 1
- Chapter 2, "CSM macroinstructions," on page 21
- Appendix A, "IVTCSM macroinstruction return and reason codes," on page 77, Appendix B, "CSM DSECTs," on page 81, Appendix C, "Related protocol specifications," on page 85, Appendix D, "Architectural specifications," on page 109, and Appendix E, "Accessibility," on page 111 provide additional information for this document.
- "Notices" on page 115 contains notices and trademarks used in this document.
- "Bibliography" on page 125 contains descriptions of the documents in the *z/OS® Communications Server* library.

---

## How to use this document

To use this document, you should be familiar with System/390 or zSeries host.

### Determining whether a publication is current

As needed, IBM® updates its publications with new and changed information. For a given publication, updates to the hardcopy and associated BookManager® softcopy are usually available at the same time. Sometimes, however, the updates

to hardcopy and softcopy are available at different times. The following information describes how to determine if you are looking at the most current copy of a publication:

- At the end of a publication's order number there is a dash followed by two digits, often referred to as the dash level. A publication with a higher dash level is more current than one with a lower dash level. For example, in the publication order number GC28-1747-07, the dash level 07 means that the publication is more current than previous levels, such as 05 or 04.
- If a hardcopy publication and a softcopy publication have the same dash level, it is possible that the softcopy publication is more current than the hardcopy publication. Check the dates shown in the Summary of Changes. The softcopy publication might have a more recently dated Summary of Changes than the hardcopy publication.
- To compare softcopy publications, you can check the last 2 characters of the publication's file name (also called the book name). The higher the number, the more recent the publication. Also, next to the publication titles in the CD-ROM booklet and the readme files, there is an asterisk (\*) that indicates whether a publication is new or changed.

## How to contact IBM service

For immediate assistance, visit this website: <http://www.software.ibm.com/network/commserver/support/>

Most problems can be resolved at this website, where you can submit questions and problem reports electronically, and access a variety of diagnosis information.

For telephone assistance in problem diagnosis and resolution (in the United States or Puerto Rico), call the IBM Software Support Center anytime (1-800-IBM-SERV). You will receive a return call within 8 business hours (Monday – Friday, 8:00 a.m. – 5:00 p.m., local customer time).

Outside the United States or Puerto Rico, contact your local IBM representative or your authorized IBM supplier.

If you would like to provide feedback on this publication, see “Communicating your comments to IBM” on page 133.

---

## Conventions and terminology that are used in this document

Commands in this book that can be used in both TSO and z/OS UNIX environments use the following conventions:

- When describing how to use the command in a TSO environment, the command is presented in uppercase (for example, NETSTAT).
- When describing how to use the command in a z/OS UNIX environment, the command is presented in bold lowercase (for example, **netstat**).
- When referring to the command in a general way in text, the command is presented with an initial capital letter (for example, Netstat).

All the exit routines described in this document are *installation-wide exit routines*. The installation-wide exit routines also called installation-wide exits, exit routines, and exits throughout this document.

The TPF logon manager, although included with VTAM, is an application program; therefore, the logon manager is documented separately from VTAM.

Samples used in this book might not be updated for each release. Evaluate a sample carefully before applying it to your system.

**Note:** In this information, you might see the term RDMA network interface card (RNIC) that is used to refer to the IBM 10GbE RoCE Express feature.

For definitions of the terms and abbreviations that are used in this document, you can view the latest IBM terminology at the IBM Terminology website.

## Clarification of notes

Information traditionally qualified as Notes is further qualified as follows:

**Note** Supplemental detail

**Tip** Offers shortcuts or alternative ways of performing an action; a hint

### Guideline

Customary way to perform a procedure

**Rule** Something you must do; limitations on your actions

### Restriction

Indicates certain conditions are not supported; limitations on a product or facility

### Requirement

Dependencies, prerequisites

**Result** Indicates the outcome

---

## How to read a syntax diagram

This section describes how to read the syntax diagrams used in this book.

- Read the diagrams from left-to-right, top-to-bottom, following the main path line. Each diagram begins on the left with double arrowheads (▶▶) and ends on the right with two arrowheads facing each other (◀◀).

▶▶ | Syntax Diagram | —————▶▶

- If a diagram is longer than one line, the first line ends with a single arrowhead (▶) and the second line begins with a single arrowhead.

▶▶ | First Line | —OPERAND1—OPERAND2—OPERAND3—OPERAND4—OPERAND5—▶

▶ | Second Line | —————▶▶

- Required operands and values appear on the main path line.

▶▶—REQUIRED\_OPERAND—▶▶

You must code required operands and values.

If there is more than one mutually exclusive required operand or value to choose from, they are stacked vertically in alphanumeric order.



- Optional operands and values appear below the main path line.



You can choose not to code optional operands and values.

If there is more than one mutually exclusive optional operand or value to choose from, they are stacked vertically in alphanumeric order below the main path line.

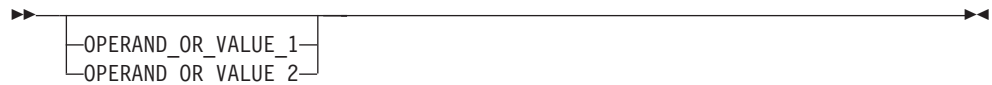

- An arrow returning to the left above an operand or value on the main path line means that the operand or value can be repeated. The comma means that each operand or value must be separated from the next by a comma.



- An arrow returning to the left above a group of operands or values means more than one can be selected, or a single one can be repeated.

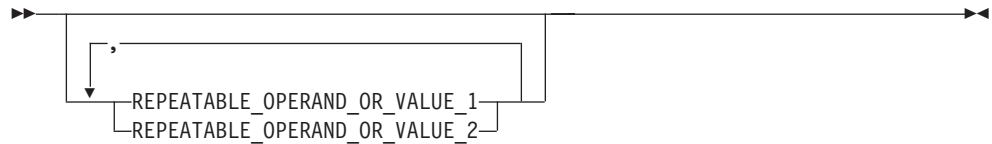

- A word in all uppercase is an operand or value you must spell exactly as shown. In this example, you must code *OPERAND*.

**Note:** VTAM and IP commands are not case sensitive. You can code them in uppercase or lowercase. If the operand is shown in both uppercase and lowercase, the uppercase portion is the abbreviation (for example, OPERand).



If an operand or value can be abbreviated, the abbreviation is described in the text associated with the syntax diagram.

- If a diagram shows a character that is not alphanumeric (such as parentheses, periods, commas, and equal signs), you must code the character as part of the syntax. In this example, you must code *OPERAND=(001,0.001)*.



- If a diagram shows a blank space, you must code the blank space as part of the syntax. In this example, you must code *OPERAND=(001 FIXED)*.

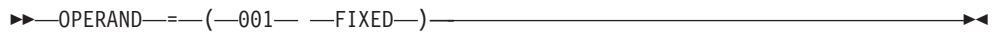

- Default operands and values appear above the main path line. VTAM uses the default if you omit the operand entirely.



- A word in all lowercase italics is a *variable*. Where you see a variable in the syntax, you must replace it with one of its allowable names or values, as defined in the text.



- References to syntax notes appear as numbers enclosed in parentheses above the line. Do not code the parentheses or the number.



**Notes:**

- 1 An example of a syntax note.
- Some diagrams contain *syntax fragments*, which serve to break up diagrams that are too long, too complex, or too repetitious. Syntax fragment names are in mixed case and are shown in the diagram and in the heading of the fragment. The fragment is placed below the main diagram.



**Syntax Fragment:**



---

## Prerequisite and related information

z/OS Communications Server function is described in the z/OS Communications Server library. Descriptions of those documents are listed in “Bibliography” on page 125, in the back of this document.

### Required information

Before using this product, you should be familiar with TCP/IP, VTAM, MVS™, and UNIX System Services.

## Softcopy information

Softcopy publications are available in the following collection.

Titles	Order Number	Description
<i>IBM System z® Redbooks Collection</i>	SK3T-7876	The IBM Redbooks® publications selected for this CD series are taken from the IBM Redbooks inventory of over 800 books. All the Redbooks publications that are of interest to the zSeries platform professional are identified by their authors and are included in this collection. The zSeries subject areas range from e-business application development and enablement to hardware, networking, Linux, solutions, security, parallel sysplex, and many others. For more information about the Redbooks publications, see <a href="http://www-03.ibm.com/systems/z/os/zos/zfavorites/">http://www-03.ibm.com/systems/z/os/zos/zfavorites/</a> .

## Other documents

This information explains how z/OS references information in other documents.

When possible, this information uses cross-document links that go directly to the topic in reference using shortened versions of the document title. For complete titles and order numbers of the documents for all products that are part of z/OS, see z/OS Information Roadmap (SA23-2299). The Roadmap describes what level of documents are supplied with each release of z/OS Communications Server, and also describes each z/OS publication.

To find the complete z/OS library, including the z/OS Information Center, see [www.ibm.com/systems/z/os/zos/bkserv/](http://www.ibm.com/systems/z/os/zos/bkserv/).

Relevant RFCs are listed in an appendix of the IP documents. Architectural specifications for the SNA protocol are listed in an appendix of the SNA documents.

The following table lists documents that might be helpful to readers.

Title	Number
<i>DNS and BIND</i> , Fifth Edition, O'Reilly Media, 2006	ISBN 13: 978-0596100575
<i>Routing in the Internet</i> , Second Edition, Christian Huitema (Prentice Hall 1999)	ISBN 13: 978-0130226471
<i>sendmail</i> , Fourth Edition, Bryan Costales, Claus Assmann, George Jansen, and Gregory Shapiro, O'Reilly Media, 2007	ISBN 13: 978-0596510299
<i>SNA Formats</i>	GA27-3136
<i>TCP/IP Illustrated, Volume 1: The Protocols</i> , W. Richard Stevens, Addison-Wesley Professional, 1994	ISBN 13: 978-0201633467
<i>TCP/IP Illustrated, Volume 2: The Implementation</i> , Gary R. Wright and W. Richard Stevens, Addison-Wesley Professional, 1995	ISBN 13: 978-0201633542
<i>TCP/IP Illustrated, Volume 3: TCP for Transactions, HTTP, NNTP, and the UNIX Domain Protocols</i> , W. Richard Stevens, Addison-Wesley Professional, 1996	ISBN 13: 978-0201634952
<i>TCP/IP Tutorial and Technical Overview</i>	GG24-3376
<i>Understanding LDAP</i>	SG24-4986
z/OS Cryptographic Services System SSL Programming	SC24-5901
z/OS IBM Tivoli Directory Server Administration and Use for z/OS	SC23-6788

<b>Title</b>	<b>Number</b>
z/OS JES2 Initialization and Tuning Guide	SA32-0991
z/OS Problem Management	SC23-6844
z/OS MVS Diagnosis: Reference	GA32-0904
z/OS MVS Diagnosis: Tools and Service Aids	GA32-0905
z/OS MVS Using the Subsystem Interface	SA38-0679
z/OS Program Directory	GI11-9848
z/OS UNIX System Services Command Reference	SA23-2280
z/OS UNIX System Services Planning	GA32-0884
z/OS UNIX System Services Programming: Assembler Callable Services Reference	SA23-2281
z/OS UNIX System Services User's Guide	SA23-2279
z/OS XL C/C++ Runtime Library Reference	SC14-7314
zEnterprise 196, System z10, System z9 and eServer zSeries OSA-Express Customer's Guide and Reference	SA22-7935

## Redbooks publications

The following Redbooks publications might help you as you implement z/OS Communications Server.

<b>Title</b>	<b>Number</b>
<i>IBM z/OS V1R13 Communications Server TCP/IP Implementation, Volume 1: Base Functions, Connectivity, and Routing</i>	SG24-7996
<i>IBM z/OS V1R13 Communications Server TCP/IP Implementation, Volume 2: Standard Applications</i>	SG24-7997
<i>IBM z/OS V1R13 Communications Server TCP/IP Implementation, Volume 3: High Availability, Scalability, and Performance</i>	SG24-7998
<i>IBM z/OS V1R13 Communications Server TCP/IP Implementation, Volume 4: Security and Policy-Based Networking</i>	SG24-7999
<i>IBM Communication Controller Migration Guide</i>	SG24-6298
<i>IP Network Design Guide</i>	SG24-2580
<i>Managing OS/390® TCP/IP with SNMP</i>	SG24-5866
<i>Migrating Subarea Networks to an IP Infrastructure Using Enterprise Extender</i>	SG24-5957
<i>SecureWay Communications Server for OS/390 V2R8 TCP/IP: Guide to Enhancements</i>	SG24-5631
<i>SNA and TCP/IP Integration</i>	SG24-5291
<i>TCP/IP in a Sysplex</i>	SG24-5235
<i>TCP/IP Tutorial and Technical Overview</i>	GG24-3376
<i>Threadsafe Considerations for CICS</i>	SG24-6351

## Where to find related information on the Internet

### z/OS

This site provides information about z/OS Communications Server release availability, migration information, downloads, and links to information about z/OS technology

<http://www.ibm.com/systems/z/os/zos/>

### **z/OS Internet Library**

Use this site to view and download z/OS Communications Server documentation

[www.ibm.com/systems/z/os/zos/bkserv/](http://www.ibm.com/systems/z/os/zos/bkserv/)

### **IBM Communications Server product**

The primary home page for information about z/OS Communications Server

<http://www.software.ibm.com/network/commserver/>

### **IBM Communications Server product support**

Use this site to submit and track problems and search the z/OS Communications Server knowledge base for Technotes, FAQs, white papers, and other z/OS Communications Server information

<http://www.software.ibm.com/network/commserver/support/>

### **IBM Communications Server performance information**

This site contains links to the most recent Communications Server performance reports.

<http://www.ibm.com/support/docview.wss?uid=swg27005524>

### **IBM Systems Center publications**

Use this site to view and order Redbooks publications, Redpapers™, and Technotes

<http://www.redbooks.ibm.com/>

### **IBM Systems Center flashes**

Search the Technical Sales Library for Techdocs (including Flashes, presentations, Technotes, FAQs, white papers, Customer Support Plans, and Skills Transfer information)

<http://www.ibm.com/support/techdocs/atmastr.nsf>

### **RFCs**

Search for and view Request for Comments documents in this section of the Internet Engineering Task Force website, with links to the RFC repository and the IETF Working Groups web page

<http://www.ietf.org/rfc.html>

### **Internet drafts**

View Internet-Drafts, which are working documents of the Internet Engineering Task Force (IETF) and other groups, in this section of the Internet Engineering Task Force website

<http://www.ietf.org/ID.html>

Information about web addresses can also be found in information APAR III1334.

**Note:** Any pointers in this publication to websites are provided for convenience only and do not serve as an endorsement of these websites.



## DNS websites

For more information about DNS, see the following USENET news groups and mailing addresses:

### USENET news groups

comp.protocols.dns.bind

### BIND mailing lists

<https://lists.isc.org/mailman/listinfo>

#### BIND Users

- Subscribe by sending mail to [bind-users-request@isc.org](mailto:bind-users-request@isc.org).
- Submit questions or answers to this forum by sending mail to [bind-users@isc.org](mailto:bind-users@isc.org).

#### BIND 9 Users (This list might not be maintained indefinitely.)

- Subscribe by sending mail to [bind9-users-request@isc.org](mailto:bind9-users-request@isc.org).
- Submit questions or answers to this forum by sending mail to [bind9-users@isc.org](mailto:bind9-users@isc.org).

## The z/OS Basic Skills Information Center

The z/OS Basic Skills Information Center is a web-based information resource intended to help users learn the basic concepts of z/OS, the operating system that runs most of the IBM mainframe computers in use today. The Information Center is designed to introduce a new generation of Information Technology professionals to basic concepts and help them prepare for a career as a z/OS professional, such as a z/OS systems programmer.

Specifically, the z/OS Basic Skills Information Center is intended to achieve the following objectives:

- Provide basic education and information about z/OS without charge
- Shorten the time it takes for people to become productive on the mainframe
- Make it easier for new people to learn z/OS

To access the z/OS Basic Skills Information Center, open your web browser to the following website, which is available to all users (no login required):  
<http://publib.boulder.ibm.com/infocenter/zos/basics/index.jsp>



---

## Summary of changes

This section describes the release enhancements that were made.

### **New in z/OS Version 2 Release 1**

For specifics on the enhancements for z/OS Version 2, Release 1, see the following publications:

- z/OS Summary of Message and Interface Changes
- z/OS Introduction and Release Guide
- z/OS Planning for Installation
- z/OS Migration



---

## Chapter 1. Communications storage manager (CSM) overview

This chapter describes CSM and its capabilities, and includes the following sections:

- “CSM application programming interface (API)”
- “Installing, defining, and initializing CSM” on page 2
- “Monitoring CSM storage” on page 2
- “Diagnosing CSM problems” on page 4
- “Application responsibilities for using CSM” on page 5
- “Functions provided by the CSM API” on page 6

The communications storage manager (CSM) is a VTAM component that allows authorized host applications to share data with VTAM and other CSM users without the need to physically copy the data.

CSM is provided as part of the high performance data transfer (HPDT) family of services. HPDT optimizes system performance for the transfer of bulk data. By providing a means for authorized applications to share buffers, CSM improves system performance during the transfer of bulk data by reducing the processing required for data movement. As a result, the following central processing unit (CPU) resources are conserved:

- CPU cycles
- Memory bus
- Cache

---

### CSM application programming interface (API)

CSM includes an application programming interface (API) that provides a way to:

- Obtain and return CSM buffers
- Change ownership of buffers
- Copy buffers
- Manage CSM buffers

**Requirement:** Applications must be authorized to use CSM.

The storage key for CSM buffers is key 6, fetch protected. Users set up and access data that resides in CSM buffers. These buffers are obtained from buffer pools that are identified by their buffer size and storage type as listed in Table 1.

*Table 1. Buffer pools in CSM*

Storage types	Buffer sizes				
31-bit-backed data space	4 KB	16 KB	32 KB	60 KB	180KB
64-bit-backed data space	4 KB	16 KB	32 KB	60 KB	180KB
ECSA	4 KB	16 KB	32 KB	60 KB	180KB

Data space storage is a common area data space and is associated with the master scheduler address space. This association results in a data space that persists for the life of the system.

When an application obtains buffers from CSM, that application is considered the owner of those buffers. Based on application specifications, CSM associates buffer responsibility with an address space or a task within an address space. Applications using CSM have the responsibility of returning owned buffers so that storage is available for other users.

Ownership can be transferred to another user. When this occurs, the new owner is responsible for the return of the buffers. CSM manages buffer reclamation during termination at the task or address space level based on ownership. For detailed information about buffer reclamation during termination, see “CSM recovery for normal and abnormal termination” on page 19.

For more information about buffer ownership, see “Ownership of buffers” on page 10.

---

## Installing, defining, and initializing CSM

CSM is shipped and installed with the VTAM product tape. However, many CSM functions are independent of VTAM. CSM storage limits and tuning parameters are defined in the CSM parmlib member, IVTPRM00. See the z/OS Communications Server: New Function Summary for information about the CSM parmlib member.

CSM is initialized by the first request to create a pool of buffers and remains active for the life of the system, independent of VTAM's status. The CREATE\_POOL request could be issued by VTAM or a host application. Upon initialization, CSM reads the CSM parmlib member to determine storage limits and buffer pool related values. After CSM is initialized, it persists for the life of the system.

---

## Monitoring CSM storage

System operators can issue the DISPLAY CSM command to monitor CSM storage usage.

**Rule:** CSM messages always start with the message prefix IVT.

For a complete list of messages issued by CSM, see the z/OS Communications Server: SNA Messages.

The DISPLAY CSM command yields the following information:

- Amount of storage allocated to each pool
- Amount of storage allocated to each user of the pool
- If OWNERID=ALL is specified, the cumulative storage allocated to each user across all pools
- If OWNERID is not specified, the highest level of fixed storage obtained since the last DISPLAY CSM command was issued without the OWNERID parameter.
- If OWNERID is not specified, the highest level of fixed storage obtained since the IPL.
- If OWNERID is not specified, the highest level of ECSA obtained since the last DISPLAY CSM command was issued without the OWNERID parameter.

- If OWNERID is not specified, the highest level of ECSA obtained since the IPL.
- If OWNERID is not specified, the names of CSM data spaces.
- The maximum amount of fixed and ECSA storage that can be allocated by CSM and current values of fixed and ECSA storage.

Use the DISPLAY CSM command to identify a user of the pool that is consuming inordinate amounts of storage. This can happen if an application fails to free buffers that it obtained from CSM. The report of storage allocated to a user is based on the value of the user's *owner\_ID* parameter. This is the OWNERID operand on the DISPLAY CSM command. CSM uses the application's address space identifier (ASID) as the OWNERID.

In some cases, the sum of the total of the storage allocated to all users of a pool might be greater than the total amount of storage allocated to a pool. This is caused by multiple buffer owners, which is a result from the creation of shared instances using the "IVTCSM REQUEST=ASSIGN\_BUFFER" on page 23 macroinstruction. The OWNERID information indicates the amount of storage that the user must free to enable the storage to be returned to the buffer pool. Issue the MODIFY CSM command to increase or decrease CSM storage limits without requiring a re-IPL.

The CSM monitor function is available to monitor CSM buffers between many components of z/OS Communications Server. IBM Software Support uses this function to help diagnose CSM storage problems.

This function is controlled using the Modify CSM command with the MONITOR operand. Valid options are MONITOR=YES, MONITOR=NO and MONITOR=DYNAMIC. If you choose MONITOR=DYNAMIC, CSM buffer monitoring is dynamically activated and deactivated. CSM dynamically activates CSM buffer monitoring when CSM storage usage reaches 80% of defined limits of the fixed storage or ECSA storage. It dynamically deactivates CSM buffer monitoring when CSM storage usage returns to 75% of defined limits of the fixed storage and ECSA storage. Use the Display CSM command with the MONITOR operand to display the function status.

Use the DISPLAY CSMUSE command to evaluate the use of storage managed by CSM. Although this command is similar to the DISPLAY CSM command, it provides a lower level of detail for storage usage; therefore, this command is different than that of the DISPLAY CSM command. This command is primarily intended for IBM service. However, it can also be beneficial to the user. The display output provides detailed information about each CSM storage pool. The detailed information describes storage as it corresponds to an identifier, which is referred to as a monitor ID. Monitor IDs describe specific z/OS Communications Server components. When CSM storage is associated with (or isolated to) a specific monitor ID, then IBM service can correlate the monitor ID to a component (usage or function) of z/OS Communications Server. This information can be useful when evaluating how z/OS Communications Server is using system storage or to help diagnose storage growth. See the z/OS Communications Server: IP and SNA Codes for the complete description of monitor IDs. The critical level storage usage is 90% or higher of ECSA MAX or FIXED MAX values specified in CSM parmlib IVTPRM00. The normal level storage usage is 80% or below of ECSA MAX or FIXED MAX values.

CSM issues some messages when CSM storage limits are at a critical level or exceeded. In this case, the system operator can issue the MODIFY CSM command to increase the amount of fixed or ECSA storage available for CSM.

For more information about these CSM commands, see the z/OS Communications Server: SNA Operation.

Use the DISPLAY TRL command to isolate a storage problem to a specific device. For more information, see z/OS Communications Server: SNA Diagnosis Vol 1, Techniques and Procedures. For more detail on the DISPLAY TRL command, see the z/OS Communications Server: SNA Operation.

CSM storage information is also provided to the performance monitor interface (PMI). This information is equivalent to the information provided for the summary format of the DISPLAY CSM command. See the z/OS Communications Server: SNA Customization for more information.

Applications using the CSM API can also request information about the status of CSM storage by issuing the "IVTCSM REQUEST=RESOURCE\_STATS" on page 73 macroinstruction.

---

## Diagnosing CSM problems

Use the CSM option on the VTAM internal trace (VIT) or, when VTAM is not active, the GTF trace facility to obtain trace output of application requests to CSM.

When VTAM is operational, the CSM trace facility is controlled using VIT. CSM writes records to the VIT using VTAM trace interfaces. The CSM trace option controls the generation of CSM trace records for both internal and external tracing.

When VTAM is not operational, the VIT is not available and only external tracing is provided. The external trace is generated using the VTAM GTF event ID to write trace records directly to GTF in the same format as those recorded using VIT.

CSM tracing records the parameter list information that flows across the CSM interface and key internal events (such as pool expansion and contraction) for functions that manipulate buffer states. This allows you to trace and analyze the usage history of a buffer.

The number of trace records required to represent one IVTCSM request varies based on the number of buffer operations requested. Because the information required to trace one IVTCSM request can span several CSM trace records, you can use the trace record flag field to determine whether additional trace records exist for a particular IVTCSM request. If the first bit in the trace record flag field is set to **on**, the trace record is continued. If VIT is not active, multiple trace records for an IVTCSM request could be interspersed with trace records of IVTCSM requests from other users. A unique trace record number correlates the continuation trace records for each IVTCSM request.

For more information about tracing events over the CSM API, see z/OS Communications Server: SNA Diagnosis Vol 1, Techniques and Procedures.



## Formatting CSM dump information

Interactive Problem Control System (IPCS) dump formatters provide the following services for displaying CSM information in a dump:

- Find and display CSM data structures including all pools and their extents.
- Find and display CSM data structures for a buffer pool based on the size and source, ECSA, or data space
- Find and display a buffer based on the input buffer token
- Find all buffers based on an input OWNERID
- Find all buffers based on input COMPID with the OWNERID or without OWNERID for all CSM pools.
- Display the summary of all COMPIDs for all CSM pools. For more information, see techniques and procedures information in *z/OS Communications Server: SNA Diagnosis Vol 1, Techniques and Procedures*.

All information is displayed with a header that identifies the contents followed by hexadecimal contents only; no field identification is provided.

**Restriction:** Formatting options that display information in buffers can provide the requested data only when the required storage areas are included in the dump.

---

## Application responsibilities for using CSM

**Requirement:** An application must be authorized in order to use the CSM API. This is described in *z/OS Communications Server: SNA Programming*.

As system-authorized applications, all programs using CSM should be written to handle CSM storage in a responsible manner. Therefore, the application design should adhere to the following guidelines for requesting CSM services. Applications using CSM for VTAM's high performance data transfer (HPDT) service should see the guidelines described in the *z/OS Communications Server: SNA Programmer's LU 6.2 Guide*.

### Guidelines:

- Data in CSM storage should be modified only by the original requester of the buffers. The original requester is the application that obtained the storage using the "IVTCSM REQUEST=GET\_BUFFER" on page 61 macroinstruction. All other applications are considered borrowers of the buffers and must treat the data as read-only. For information about possible exceptions to this rule, see "Responsibilities of buffer ownership" on page 11 for more details.
- All programs directly referencing CSM storage must do so in the proper storage key. All CSM storage is allocated in key 6.  
The "IVTCSM REQUEST=COPY\_DATA" on page 34 macroinstruction allows data to be copied into or out of CSM storage. The authorized invoker can be in any key. Using this service might reduce the impact to the application due to storage key mismatches when CSM storage must be accessed.
- An application must not reference or use CSM storage after passing ownership of that storage to another user.
- An application that has accepted ownership of CSM storage is obligated to return the storage to CSM unless that application is passing the storage to

another user. See “Ownership of buffers” on page 10 for more information. Storage is returned to CSM on the “IVTCSM REQUEST=FREE\_BUFFER” on page 56 macroinstruction.

- Applications should use the “IVTCSM REQUEST=RESOURCE\_STATS” on page 73 macroinstruction to monitor the status of CSM storage. The application must be capable of reacting to storage constraint conditions that might jeopardize the application's or system's operation. See “Obtaining CSM resource statistics” on page 16 for more information. The RESOURCE\_STATS request is described on page “IVTCSM REQUEST=RESOURCE\_STATS” on page 73.
- Generally, applications should request buffers from data space instead of ECSA to ensure that more virtual storage is available to all users of CSM. ECSA should be used only if there are special application requirements.
- The application's use of CSM should be documented so that the installation can adjust ECSA and fixed storage limits in the CSM parmlib member as necessary. This information should be available in application installation documentation so that necessary changes to the limits can be made prior to application installation.

---

## Functions provided by the CSM API

This section describes the functions that a CSM user needs in order to create and use storage pools. The IVTCSM macroinstruction provides the interface for applications issuing requests to CSM.

Use the IVTCSM macroinstruction to issue the following types of requests:

- “IVTCSM REQUEST=ASSIGN\_BUFFER” on page 23
- “IVTCSM REQUEST=CHANGE\_OWNER” on page 29
- “IVTCSM REQUEST=COPY\_DATA” on page 34
- “IVTCSM REQUEST=CREATE\_POOL” on page 40
- “IVTCSM REQUEST=DELETE\_POOL” on page 46
- “IVTCSM REQUEST=DUMP\_INFO” on page 49
- “IVTCSM REQUEST=FIX\_BUFFER” on page 52
- “IVTCSM REQUEST=FREE\_BUFFER” on page 56
- “IVTCSM REQUEST=GET\_BUFFER” on page 61
- “IVTCSM REQUEST=PAGE\_BUFFER” on page 68
- “IVTCSM REQUEST=RESOURCE\_STATS” on page 73

See Chapter 2, “CSM macroinstructions,” on page 21 for the complete description and syntax of each request.

Table 2 on page 7 contains a cross reference of IVTCSM requests and their valid input and output parameters.

Table 2. Valid operands for IVTCSM macroinstruction

REQUEST	C R E A T E  P O O L	D E L E T E  P O O L	G E T  B U F F E R	F R E E  B U F F E R	A S S I G N  B U F F E R	C H A N G E  O W N E R	F I X  B U F F E R	P A G E  B U F F E R	C O P Y  D A T A	D U M P  I N F O	R E S O U R C E  S T A T S
PLISTVER	Oi	Oi	Oi	Oi	Oi	Oi	Oi	Oi	Oi	Oi	Oi
BACK	Oi										
BUFLIST			Ri	Ri	Ri	Ri	Ri	Ri			
BUFNUM			Ri	Ri	Ri	Ri	Ri	Ri			
BUFSIZE	Ri										
BUFSOURC	Ri										
BUFTYPE			Ri		Oi			Ri			
CLEAR			Oi	Oi							
DS_INFO	Oo									Oo	
ERRBFLST			Oo	Oo	Oo	Oo	Oo	Oo			
EXPBUF	Ri										
FREERTN			Oi								
FREETO				Oi							
GAP			Oi	Oi	Oi	Oi	Oi	Oi			
INITBUF	Ri										
MF	Ri	Ri	Ri	Ri	Ri	Ri	Ri	Ri	Ri	Ri	Ri
MINFREE	Ri										
OWNERID			Oi		Oi	Oi					
PAD									Oi		
POOLTOKN		Ri	Ri								
PADCHAR									Oi		
RETCODE	Oo	Oo	Oo	Oo	Oo	Oo	Oo	Oo	Oo	Oo	Oo
RETPTOKN	Oo										
RSNCODE	Oo	Oo	Oo	Oo	Oo	Oo	Oo	Oo	Oo	Oo	Oo
SKIPBUF				Oi		Oi					
SRCERRL									Oo		
SRCGAP									Oi		
SRCLIST									Ri		
SRCNUM									Ri		
STATAREA	Oo										Oo

Table 2. Valid operands for IVTCSM macroinstruction (continued)

REQUEST	C R E A T E  P O O L	D E L E T E  P O O L	G E T  B U F F E R	F R E E  B U F F E R	A S S I G N  B U F F E R	C H A N G E  O W N E R	F I X  B U F F E R	P A G E  B U F F E R	C O P Y  D A T A	D U M P  I N F O	R E S O U R C E  S T A T S
TARGERRL									Oo		
TARGGAP									Oi		
TARGLIST									Ri		
TARGNUM									Ri		
TASKID			Oi		Oi	Oi					
THREAD			Oi	Oi	Oi	Oi	Oi	Oi	Oi		
UTILRTN			Oi	Oi	Oi	Oi	Oi	Oi	Oi		
WAIT			Oi				Oi				

**Key:** R=Required O=Optional i=input o=output

## Creating and registering buffer pools

Upon application request, CSM can create buffer pools based on the size and types listed in Table 1 on page 1. A total of 15 CSM buffer pools can be created, one for each storage type and buffer size.

The structures that maintain the storage pools are created as a result of the first “IVTCSM REQUEST=CREATE\_POOL” on page 40 macroinstruction issued by a CSM user (this could be VTAM or a host application). The pool might or might not already exist. In either case, the application that issues the CREATE\_POOL request is a registered user and can obtain buffers from that pool. CSM returns a token in the RETPTOKN parameter, which the application uses on subsequent requests for buffer requests from that pool.

An application can specify buffer pool tuning parameters on the CREATE\_POOL request. See “CSM buffer pool expansion and contraction” on page 17 for more information.

**Guideline:** Where possible, programs should use CSM data space instead of ECSA. Furthermore, use of 64-bit backed CSM data space is preferred to 31-bit backed CSM data space. Use data space instead of ECSA and 64-bit backed data space instead of 31-bit backed data space to benefit overall system performance.

## Requesting storage from CSM

**Requirement:** Before an application can retrieve storage from CSM, it must be registered as a user of a CSM buffer pool. See “Creating and registering buffer pools” on page 8 for a description.

Table 1 on page 1 lists a summary of the available CSM buffer pools. CSM returns a pool token in the RETPTOKN parameter, which the application uses on subsequent buffer requests from that pool.

Applications obtain buffers from CSM by specifying the token of the pool with which they are registered and the number of buffers on the “IVTCSM REQUEST=GET\_BUFFER” on page 61 macroinstruction. CSM allocates the requested number of buffers from that pool to the application. CSM returns a buffer list. Each entry in the buffer list contains a token and other information that the application and CSM use to reference the buffers. See “CSM buffer lists” for more information about buffer lists in CSM.

An application can obtain buffers from CSM as they are needed or manage its own pool of buffers to be retained for multiple uses. By default, buffers are returned to CSM when the current owner issues the “IVTCSM REQUEST=FREE\_BUFFER” on page 56 macroinstruction. An application designed to manage its own pool of buffers uses a buffer return exit routine that assumes control of the buffers after they are freed by a user.

Buffer return exit routines can receive control after buffers are released by a FREE\_BUFFER request. See “Buffer return exit routine” on page 18 for more information.

**Restriction:** GET\_BUFFER requests that exceed the storage available in CSM are rejected. CSM users should monitor CSM storage use and take action to prevent critical shortages that might jeopardize the application or system operation. See “Obtaining CSM resource statistics” on page 16 for more information.

## CSM buffer lists

The following requests require that the application provide the buffer list address:

- “IVTCSM REQUEST=ASSIGN\_BUFFER” on page 23
- “IVTCSM REQUEST=CHANGE\_OWNER” on page 29
- “IVTCSM REQUEST=FIX\_BUFFER” on page 52
- “IVTCSM REQUEST=FREE\_BUFFER” on page 56
- “IVTCSM REQUEST=GET\_BUFFER” on page 61
- “IVTCSM REQUEST=PAGE\_BUFFER” on page 68

CSM builds a buffer list in the area provided on the BUFLIST parameter of the GET\_BUFFER request. The buffer list contains, among other information, a token used by CSM to manage each buffer. The format of the CSM buffer list is described in “CSM buffer list entry (IVTBUFL)” on page 81. The IVTBUFL DSECT maps an entry in the CSM buffer list, which can be indicated by the BUFLIST, SRCLIST or TARGLIST parameters on the IVTCSM macroinstruction.

**Tip:** Each buffer list entry can be contiguous to the previous entry with the number of entries in the list defined by the BUFNUM operand on the request. Use the GAP parameter to separate entries.

## Fixed buffers versus pageable buffers

Applications can specify buffers in one of the following formats:

- Guaranteed to be fixed (BUFTYPE=FIXED)
- Guaranteed to be pageable (BUFTYPE=PAGEABLE)
- Eligible to be made pageable (BUFTYPE=PAGEELIG)

### Guaranteeing that a buffer is fixed

Some processes require buffers to be fixed into real storage. An application can specify fixed buffers (BUFTYPE=FIXED parameter) on the GET\_BUFFER and ASSIGN\_BUFFER requests. Availability of fixed buffers is limited by the system definitions in the installation's CSM parmlib member. The application can obtain pageable buffers when fixed buffers are unavailable and use the FIX\_BUFFER request to make the buffers fixed at a later time.

### Guaranteeing that a buffer is pageable

An application can specify BUFTYPE=PAGEABLE on the GET\_BUFFER and PAGE\_BUFFER requests to classify buffers as guaranteed to be made pageable.

**Restriction:** This function can be issued for a buffer consisting of only one image. For information about creating multiple images of a buffer, see "IVTCSM REQUEST=ASSIGN\_BUFFER" on page 23.

### Making a buffer eligible to be paged

An application can specify BUFTYPE=PAGEELIG on the GET\_BUFFER, ASSIGN\_BUFFER, and PAGE\_BUFFER requests in order to classify buffers as eligible to be paged. CSM can maintain a status of eligible to be paged. The actual system state of a buffer with this status can be either fixed or pageable. CSM internally monitors the level of fixed storage usage. The buffers can remain fixed unless CSM determines that the storage should be made pageable. This avoids the unnecessary overhead of fixing and freeing storage from a system perspective.

This function avoids consuming fixed storage for data that is being held in a buffer for possible use at a later time.

**Requirement:** If an eligible to be paged buffer must be fixed later, the application must issue the FIX\_BUFFER request.

## Ownership of buffers

CSM uses the address space identifier (ASID) as the basis for the OWNERID value. OWNERID can be specified on the following requests:

- "IVTCSM REQUEST=ASSIGN\_BUFFER" on page 23
- "IVTCSM REQUEST=GET\_BUFFER" on page 61
- "IVTCSM REQUEST=CHANGE\_OWNER" on page 29

The owner is the application responsible for returning buffers to CSM using the "IVTCSM REQUEST=FREE\_BUFFER" on page 56 macroinstruction. CSM assigns initial buffer ownership to the original requester of the buffers. To override this assignment, specify another user's ASID as the OWNERID on the "IVTCSM

REQUEST=GET\_BUFFER” on page 61 macroinstruction. To pass on ownership of CSM buffers to another, issue an “IVTCSM REQUEST=CHANGE\_OWNER” on page 29 macroinstruction.

To associate ownership of a buffer to a task, specify a TCB address on the TASKID parameter on the following requests:

- “IVTCSM REQUEST=ASSIGN\_BUFFER” on page 23
- “IVTCSM REQUEST=GET\_BUFFER” on page 61
- “IVTCSM REQUEST=CHANGE\_OWNER” on page 29

If TASKID is not specified, buffer ownership is associated with the ASID.

Ownership of a buffer that has an associated buffer return exit is not actually changed due to an IVTCSM REQUEST=CHANGE\_OWNER macroinstruction; the buffer is actually borrowed. The original owner of the buffer is maintained so that ownership is restored when the buffer is freed. However, if the original owner's address space terminates before the buffer return exit is invoked, the current borrower, if one exists, becomes the new owner. If the buffer is not being borrowed, it is returned to CSM.

## Responsibilities of buffer ownership

When an application obtains buffers from CSM on a “IVTCSM REQUEST=GET\_BUFFER” on page 61 macroinstruction, that application is considered to be the original requester of that storage. Ownership responsibility entails either ultimately freeing the storage (on an “IVTCSM REQUEST=FREE\_BUFFER” on page 56 macroinstruction) or changing ownership to another user. Failure to return the storage ultimately creates CSM storage constraint conditions.

The original requester of the storage can specify a buffer return exit routine at storage allocation time and is entitled to the return of storage without modification.

**Guideline:** The receiving application should consider this as read-only storage and should not modify the contents.

If written as a cooperative set of processes, applications might determine that it is acceptable to modify the data if the original application does not require the original data returned unmodified.

**Restriction:** Applications written in this manner must be able to guarantee that the original requester of the storage is one of the cooperative applications. If the storage allocation source is unknown to the receiver, the read-only requirement applies.

## Changing ownership of a buffer

Any user that can address the buffers by using the buffer tokens provided by CSM can issue the CHANGE\_OWNER request. This includes the following scenarios:

- Application A passes buffer tokens to application B. Application B issues the “IVTCSM REQUEST=CHANGE\_OWNER” on page 29 macroinstruction.
- Application A uses the “IVTCSM REQUEST=CHANGE\_OWNER” on page 29 macroinstruction to pass ownership of the buffers to application B.

**Restriction:** After an ownership change, the former owner of the buffers must not address the buffers except when the former owner has specified a buffer return exit. In this case, the application must not address the buffers until its exit routine is scheduled by CSM. The exit routine is scheduled when the current owner of the buffers issues the “IVTCSM REQUEST=FREE\_BUFFER” on page 56 macroinstruction.

**Example:**

The High Performance data transfer (HPDT) interface demonstrates how two CSM users change ownerships.

On an HPDT send, the application passes the buffer tokens to VTAM in an extended buffer list (XBUFLST) on the send request. VTAM performs the CHANGE\_OWNER request. If an error occurs, VTAM notifies the application so that the application can recover buffers that were not accepted. On the receive side, VTAM passes the buffer list to the application and issues the CHANGE\_OWNER request.

## Storage return

An application uses the “IVTCSM REQUEST=FREE\_BUFFER” on page 56 macroinstruction to release buffers back to CSM.

CSM returns the buffers to the original requester if all of the following conditions exist:

- The original requester specified a buffer return exit address on the FREERTN parameter of the “IVTCSM REQUEST=GET\_BUFFER” on page 61 macroinstruction.
- The original requester is active at the time the “IVTCSM REQUEST=FREE\_BUFFER” on page 56 macroinstruction is issued.
- The application issuing “IVTCSM REQUEST=FREE\_BUFFER” on page 56 does not specify FREETO=CSM. This parameter is intended for situations where the original requester needs to return buffers without invoking its own buffer return exit.

Optionally, the requester can specify that the buffer is to be cleared when issuing the FREE\_BUFFER request. See “Clearing data from buffers” for more information.

**Requirement:** All storage manager GET\_BUFFER and ASSIGN\_BUFFER requests must have a corresponding FREE\_BUFFER request before the buffer is considered available for reallocation by CSM or before a buffer return exit is invoked for a buffer obtained specifying a user free routine. This ensures that all users have finished using the buffer.

## Clearing data from buffers

An application can instruct CSM to clear data from buffers that are returned to the buffer pool by specifying CLEAR=YES on the following macroinstructions:

- “IVTCSM REQUEST=FREE\_BUFFER” on page 56
- “IVTCSM REQUEST=GET\_BUFFER” on page 61

This passes secure data to another user such that any residual data is eliminated when that buffer has returned to the pool.



**Notes:**

- Specifying CLEAR=YES on a “IVTCSM REQUEST=GET\_BUFFER” on page 61 macroinstruction overrides a CLEAR=NO specification on a “IVTCSM REQUEST=FREE\_BUFFER” on page 56 macroinstruction.
- Specifying CLEAR=YES does not cause a buffer to be cleared that is returned to an application's buffer return exit routine. However, if CLEAR=YES is specified, the buffer is cleared in the event that it is returned to the storage pool.

## Removing registration from a pool

Because each pool can have multiple users, a storage pool is not deleted until all buffers have been returned by all users and DELETE\_POOL requests have been received for each corresponding CREATE\_POOL request. To deregister as the user of the pool, the application issues the “IVTCSM REQUEST=DELETE\_POOL” on page 46 macroinstruction.

## Copying data to or from a CSM buffer

Applications can use the “IVTCSM REQUEST=COPY\_DATA” on page 34 macroinstruction to copy data to or from a CSM buffer or a user data area. The authorized invoker can be in any key. This request might reduce the impact to the application by reducing storage key mismatches when CSM storage must be accessed. It also assists users of CSM data space buffers by isolating the application from the addressing method used to access a data space.

The “IVTCSM REQUEST=COPY\_DATA” on page 34 macroinstruction allows multiple source buffers to be copied to or from one or more target buffers. The source buffers are copied to the target buffers using the source and target buffer lengths to pack data or span data across the target buffers as required.

If the cumulative length of the source buffers is greater than the cumulative length of the target buffers, the source data is truncated. The application can specify a character on the PADCHAR input parameter to pad the target buffers when the cumulative length of the source buffers is less than the cumulative length of the target buffers.

The application must supply a source buffer list and a target buffer list on the COPY\_DATA request. This is shown in Figure 1 on page 14. The number of entries in each list does not have to be equal. Within each list, entries might or might not represent a CSM buffer. The value of the BUFL\_SOURCE field dictates whether the entry represents a CSM buffer. For entries representing CSM buffers, the address that is the source or target of the copy is provided by the requester and is not required to be the actual start address of the CSM buffer. CSM validates that the specified address and length correspond to a storage area that is within the bounds of the CSM buffer. This validation is based on the size of the buffer as determined at the time the buffer pool was created.

Optionally, a user data area that is involved in the copy data operation can be access list entry token (ALET)-qualified to allow this area to reside in a data space.

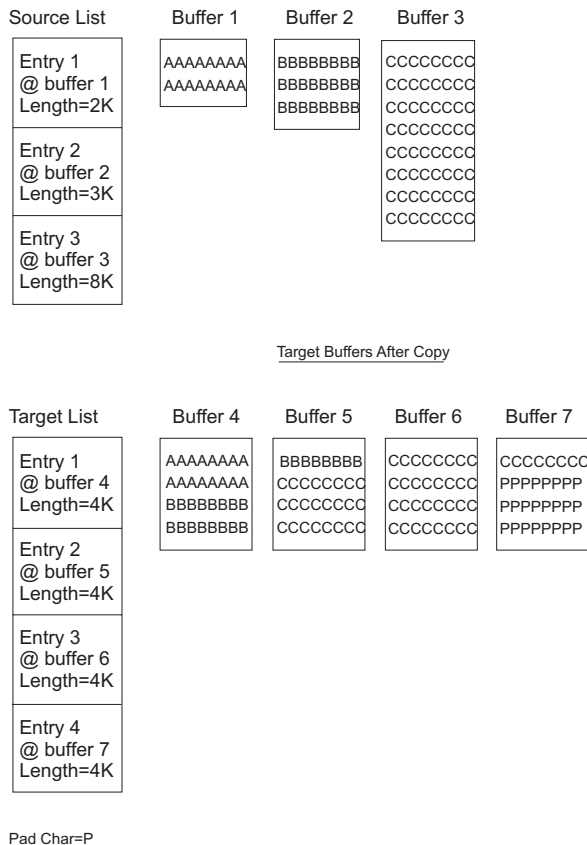

Figure 1. Example of copy data buffer list and copy results

## Sharing buffers among multiple users

The “IVTCSM REQUEST=ASSIGN\_BUFFER” on page 23 macroinstruction allows a buffer to be concurrently shared between multiple users. A logical instance of the buffer is created for each user. A new physical copy of the buffer is not created. This function allows specific areas of the buffer to be allocated to different owners. This function can be used to give multiple users read access to the same data.

**Tip:** No serialization is provided to prevent concurrent updates by users.

A new buffer token that represents the new instance of the buffer is returned. The buffer token is the means by which this new instance of the buffer is known to CSM.

**Requirement:** This token must be used with all other requests to CSM for the associated buffer instance.

On the ASSIGN\_BUFFER request, multiple shared instances of a single buffer can be created by passing a multiple entry buffer list with the same buffer token in each entry.

**Restriction:** A request to create a new image of a buffer that is in a guaranteed to be pageable state is not permitted. This restriction guarantees that a user of a buffer that has multiple images can successfully issue a FIX\_BUFFER request if

necessary. Fixing a buffer requires that the entire buffer be fixed regardless of the fact that the user might be interested in only a piece of the buffer. The application can specify the BUFTYPE parameter as described in “Fixed buffers versus pageable buffers” on page 10.

## Obtaining CSM dumping information

To debug problems associated with the application's use of CSM buffers, it might be necessary to include CSM storage in a dump.

In order to include CSM storage in a dump, an application can use the following information:

- Dumping area containing CSM data structures, pool structures, and buffer headers:
  - Location extended common service area (ECSA)
  - Subpool 241
  - Key 6

These areas can be included in a user dump by specifying the subpool and key on the invocation of the SDUMPX macroinstruction.

- Dumping buffers in an ECSA buffer pool:
  - Location Extended CSA (ECSA)
  - Subpools 231
  - Key 6

The ECSA buffer pool can be included in a user dump by specifying the subpool and key on the invocation of the SDUMPX macroinstruction.

- Dumping buffers in a data space buffer pool:
  - Location common area data space (CADS) owned by the master address space
  - Key 6
  - Data space address range 4 KB - 2 GB
  - Data space STOKENs and ALETs provided by IVTCSM REQUEST=DUMP\_INFO.

**Guideline:** Applications should include the areas containing CSM data structures by specifying the subpools and key to reduce the amount of data included in the dump. Selective dumping is most important when dumping data in a CSM data space rather than dumping the entire 2 Gigabyte contents.

For ease of dumping CSM buffers during testing, an application can use ECSA buffers because this area can be included in a dump using the subpool and key. After the application is debugged, data space buffers can be used for the production application.

An application can request the location of information required to obtain CSM data space information in a dump on the following macroinstructions:

- “IVTCSM REQUEST=CREATE\_POOL” on page 40
- “IVTCSM REQUEST=DUMP\_INFO” on page 49

The application can perform the following actions:

- Specify the address of an area on the DS\_INFO parameter where CSM places the address of the area containing the CSM data space information. This information is mapped by the IVTDATSP DSECT. See “CSM data space information (IVTDATSP)” on page 83.
- Request the information during initialization processing and use the information throughout normal processing.

Dumping the entire data space can require a long processing time and a large amount of external recording media. Because of this, you might want to limit the amount of area dumped based on address ranges within the data space believed to be pertinent to the user. For example, use the ALETs returned by the IVTCSM REQUEST=DUMP\_INFO macroinstruction to determine whether, at the time of abend, any access registers (AR) contain an ALET associated with a CSM data space. If an AR contains an ALET of a CSM data space, and the program was executing in AR mode at the time of the failure, you can dump a limited number of bytes of the data surrounding the address represented by the general register (GR) and AR pair.

## Obtaining CSM resource statistics

An application can request the address of information required to monitor usage of CSM resources such as ECSA, data space and fixed storage. The address of this information is returned on the STATAREA parameter when the following macroinstructions are issued:

- “IVTCSM REQUEST=CREATE\_POOL” on page 40
- “IVTCSM REQUEST=RESOURCE\_STATS” on page 73

The application can request the address of the resource statistics area during initialization processing and can reference this area to obtain resource statistics throughout normal processing.

For each resource type, the following bits are defined:

### Critical

Indicates that CSM storage usage is at 90% of defined limits or higher.

### Constrained

Indicates that CSM storage usage is higher than 80% of defined limits and is approaching the constrained level (85% of defined limits). If this bit is set, the application should determine if the critical bit is also set.

**Note:** If neither bit is set, the resource usage is considered to be normal.

**Restriction:** GET\_BUFFER requests that exceed the storage available in CSM are rejected.

CSM users should monitor CSM storage use and take action to prevent critical shortages that might jeopardize the application or system operation. Actions might include:

- Freeing buffers that are no longer needed
- Selecting a different storage source for buffer pools
- Limiting usage of fixed storage

IVTSTATA DSECT maps CSM resource statistics information. See “CSM resource status area (IVTSTATA)” on page 83.

## CSM buffer pool expansion and contraction

The MINFREE, INITBUF, and EXPBUF specifications in the CSM parmlib member, IVTPRM00, determine CSM buffer pools expansion and contraction. If these values are not specified in the CSM parmlib member, or if CSM cannot read that parmlib member during initialization, CSM uses the values specified by the application on the “IVTCSM REQUEST=CREATE\_POOL” on page 40 macroinstruction. If buffer pool tuning specifications are not available from either the CSM parmlib member or application request, system defaults are used.

This section describes how CSM buffer pool expansion and contraction are performed based on application settings. For more information about the CSM parmlib member, see the z/OS Communications Server: New Function Summary.

### Number of buffers when buffer pool is created using application settings

When the first CREATE\_POOL request is received, CSM creates a pool of buffers. The INITBUF parameter specifies the initial number of buffers created in that pool.

**Requirement:** INITBUF is required on the CREATE\_POOL request.

The range for INITBUF is 0 - 9999. If 0 is specified, only the base pool structure is created. In this case, the pool is expanded on the first GET\_BUFFER request based on the EXPBUF parameter value. If a value is specified that is outside of the range for INITBUF, one of the following values is used (depending on the size of the buffers in the pool).

Pool size	Initial number of buffers (INITBUF)
4096	64
16384	32
32768	16
61440	16
184320	2

### CSM buffer pool expansion using application settings

CSM buffer pools are expanded as needed to maintain the specified number of free buffers in the pool. The number of free buffers maintained is determined by the highest MINFREE (minimum free buffer) specifications by all users of a pool.

CSM buffer pools are expanded by the maximum of the EXPBUF (expand buffers) specifications by all users of a pool. The storage pool is expanded if the number of free buffers falls below MINFREE.

The pool is managed in extents. Expansion consists of creating a new extent with the number of buffers as determined by the EXPBUF parameters. The expansion of the pool is scheduled as a side process in order to avoid excessive pathlength on a “IVTCSM REQUEST=GET\_BUFFER” on page 61 macroinstruction due to inline pool expansion. In the event that pool expansion must complete to satisfy a request for buffers, the application can optionally wait for pool expansion to complete by specifying WAIT=EXPAND or WAIT=YES on the “IVTCSM REQUEST=GET\_BUFFER” on page 61 macroinstruction.

**MINFREE parameter:**

**Requirement:** MINFREE is required on the CREATE\_POOL request.

The range for MINFREE is 0 - 9999. If a value is specified that is outside of the range for MINFREE, one of the following values is used (depending on the buffer sizes in the pool).

Pool size	Minimum buffers that are free (MINFREE)
4096	8
16384	4
32768	2
61440	2
184320	1

**EXPBUF parameter:**

**Requirement:** EXPBUF is required on the CREATE\_POOL request.

The valid range for EXPBUF depends on the size of the buffers in the pool. If a value is specified that is outside of the range for EXPBUF, one of the following values is used.

Pool size	Valid range	Number of buffers to expand pool (EXPBUF)
4096	1 - 256	16
16384	1 - 256	8
32768	1 - 128	4
61440	1 - 68	4
184320	1 - 22	2

### CSM buffer pool contraction using application settings

CSM buffer pools contract as necessary to prevent the pools from consuming system resources permanently as the result of usage peaks. Contraction occurs when the number of buffers that are not in use exceeds one of the following values (whichever is higher):

- INITBUF
- MINFREE + 2(EXPBUF)

The pool does not contract when the number of buffers is below the level specified on the INITBUF parameter.

### Buffer return exit routine

An application can manage its own pool of buffers to be retained for multiple uses by coding a buffer return exit routine that assumes control of the buffers after they are freed by a user. By default, buffers are returned to CSM when the current owner issues the "IVTCSM REQUEST=FREE\_BUFFER" on page 56 macroinstruction. An application that provides the address of its buffer return exit on the FREERTN parameter of the "IVTCSM REQUEST=GET\_BUFFER" on page 61 macroinstruction receives ownership when the buffers are freed by another user.

The buffer return exit routine is scheduled to execute in the address space which owns the buffer to ensure that the owning environment still exists.

The buffer return exit routine is called by a CSM routine that receives control from the SRB scheduler. The CSM routine passes the address of the parameter list to the buffer return exit routine in register 1. To map the passed parameter list, the buffer return exit routine should include a DSECT that issues the LIST form of the IVTFREE macro. For example:

```
name    DSECT
        IVTFREE MF=(L,listaddr)
```

The parameter list contains the address of the buffer list and the number of buffer entries in the list. The following sample output shows the LIST form of the IVTFREE macroinstruction with a *listaddr* value of FREPL:

```

FREPL   DS    0D                ++ IVTFREE PARM LIST
FREPL_XVERSION DS XL1          ++ INPUT XVERSION
FREPL_XRSVFREE1 DS CL03       ++ RESERVED XRSVFREE1
FREPL_XBUFLIST DS A           ++ XBUFLIST
FREPL_XBUFNUM DS F            ++ XBUFNUM
0000C  FREPLL EQU *-FREPL      ++ LENGTH OF PLIST
```

Each buffer list entry is mapped by the IVTBUFL DSECT. The application can examine the tokens in each entry to correlate them with the buffers referenced by the original GET\_BUFFER request. When a buffer return exit is driven, the pageability of the buffer might have changed. The original buffer address, token, and length remains the same.

After regaining ownership of the buffers, the application can determine whether to release the buffers back to CSM using the FREE\_BUFFER request. To prevent looping, the application must not specify FREETO=USER on the FREE\_BUFFER request. This would reschedule the application's buffer return exit. To return the buffers back to CSM, the buffer return exit should specify FREETO=CSM on the FREE\_BUFFER request.

## CSM recovery for normal and abnormal termination

For normal or abnormal termination, CSM users free all owned buffers prior to completing termination processing. However, this might not always be possible for abnormal termination.

To ensure that buffers are not lost as a result of normal or abnormal termination, CSM uses the following resource termination managers to reclaim buffers that are owned by the terminating environment:

### Job Step Task Resource Termination Manager

Job Step Task cleanup is performed if task is not an MVS started task (for example, batch).

### Memory Resource Termination Manager

Memory cleanup is performed whenever address space memory termination occurs.

The resource managers perform the following actions:

- Receive control from recovery termination management (RTM) during job step task and memory termination processing
- Determine if any of the allocated buffers are owned by the terminating address space
- As appropriate, free the buffers back to the buffer pool

Additionally, CSM allows the user to associate buffers to a task. Buffers that are task-associated are reclaimed by CSM at the end of the specified task only if the task abnormally terminates. The user of the buffer is responsible for ensuring the buffers are freed during normal termination.

If a CSM user wants to provide recovery mechanisms to free buffers at events other than those provided by CSM, the user can create ESTAE/FRR recovery routines to recover at a program level or RESMGR to create a resource manager to recover at a task termination event not provided by CSM. When performing this type of processing, users must ensure that their application processing is properly synchronized with any applications to which they are passing buffers.



---

## Chapter 2. CSM macroinstructions

This chapter describes all varieties of the IVTCSM macroinstruction and includes the following sections:

- “How the macroinstructions are described”
- “Computing environment for the CSM API” on page 22

Separate descriptions are included for each value of the REQUEST parameter. Macroinstruction descriptions are arranged alphabetically.

---

### How the macroinstructions are described

Each macroinstruction description includes the following information:

- Purpose of the macroinstruction
- General comments about the use of the macroinstruction
- The format or syntax of the macroinstruction and all parameters
- A description of each parameter
- Return and reason codes that can be returned for the macroinstruction

#### Syntax descriptions

The syntax for each macroinstruction uses the following format:

##### main diagram



The macroinstructions are coded in the same format as assembler instructions, using name, operation, and operand fields. See the *IBM High Level Assembler Language Reference for MVS and VM* for complete information about coding guidelines.

#### Operand descriptions

The name and description of each operand follows the syntax diagram. Each operand description begins with an explanation of the operand's function.

Parameter values that are shown in uppercase bold type must be coded as they appear in the syntax. For parameter values that are shown in lowercase italic type, specify a location that is to be the source of input data or the target of output data. The location must be defined in a manner that is consistent with the indicated data type. If you wish to pass the storage address in general purpose register (2)-(12), code a valid expression for the register within parentheses. Otherwise, code an expression that is valid as a storage operand on RS-type instructions.

**Tip:** If a register is specified for RETCODE or RSNCODE, the output is loaded straight into the register.

To reference the parameter list within your program, use the list form of the macro, MF=(L,...), to define the parameter list structure. The *listaddr* value you specify becomes the name by which you can reference the structure in your program. For example, the assembler instruction LA 1,*listaddr* puts the parameter list address in register 1. The name of the field associated with a parm list operand *opername* is *listaddr\_Xopername*. If macroinstruction-defined values are associated with *opername*, the constant for a particular value, *valuenam*, is *listaddr\_Xopername\_valuenam*.

**Restriction:** The PLISTVER operand is an exception to the rule. To reference its field, substitute *opername* with the keyword **VERSION**. Also, the macro does not define constants for any of the allowable PLISTVER values.

All of the executable macroinstructions pass return codes in registers, and most indicate status information in various control block fields when they are posted complete. For all macroinstructions that invoke CSM, the application can examine return codes in register 15 and reason codes in register 0. Descriptions of this status information can be found at the end of the macroinstruction description.

---

## Computing environment for the CSM API

This section describes the environment where the IVTCSM macro is issued.

### Environment

The following requirements are for the caller:

**Minimum authorization:**

Supervisor state. Any PSW key.

**Dispatchable unit mode:**

Task or SRB.

Exception: CREATE\_POOL and DELETE\_POOL requests must be issued in Task Mode.

**Cross memory mode:**

Any PASN, any HASN, any SASN.

CREATE\_POOL and DELETE\_POOL requests are PASN=HASN=SASN only.

**AMODE:**

31-bit.

**ASC mode:**

Primary.

**Interrupt status:**

Enabled for I/O and external interrupts.

**Locks:** No locks can be held.

**Control parameters:**

Control parameters must be in the primary address space.

### Programming requirements

The user must provide a recovery environment if one is necessary during the invocation of the IVTCSM Service, as the service does not provide a recovery environment during all its functions.

The service provides for buffer reclamation at the following tasks:

- End-of-memory
- End-of-Job-Step-Task
- Optionally, at abnormal end-of-task

See “CSM recovery for normal and abnormal termination” on page 19 for more information.

## Restrictions

The caller has the following restrictions:

- Do not use MVS page-fix services directly for buffers provided by this service. Establish the BUFTYPE attribute of these buffers using CSM service requests.
- Do not issue ALESERV delete for an ALET returned from CSM.

## Input register information

Before issuing this macro, the caller must ensure that register 13 contains the address of a 72-byte standard save area in the primary address space.

## Output register information

When control returns to the caller, the general purpose registers contain the following registers:

### Register

#### Contents

0	Error reason code from the requested function
1	Used as work register by the system
2-13	Unchanged
14	Used as work register by the system
15	Return code from requested function

## IVTCSM REQUEST=ASSIGN\_BUFFER

### Purpose

This macroinstruction allows an application to request that a buffer be logically assigned to another owner (shared) in order to make multiple owners of a buffer.

### Usage

This macroinstruction allows a buffer to be concurrently shared between multiple users. A logical instance of the buffer is created for each user. A new physical copy of the buffer is not created. This macroinstruction can be used to allow specific areas of the buffer to be allocated to different owners and to allow multiple users to have read access to the same data. No serialization is provided to prevent concurrent updates by users.

The ownership of the new instance of the buffer is assigned to the requesting application's ASID by default. Ownership of a new instance of the buffer can be optionally qualified by specifying a TASKID on the macroinstruction. The TASKID is a TCB address with the default being no task association.

Upon completion of this macroinstruction, a new buffer token is returned representing the new instance of the buffer. The buffer token is the means by which this new instance of the buffer is known to CSM. This token must be used with all other requests to CSM for the associated buffer instance.

Multiple shared instances of a single buffer can be created by passing a multiple entry buffer list with the same buffer token in each entry.

## Syntax

### main diagram

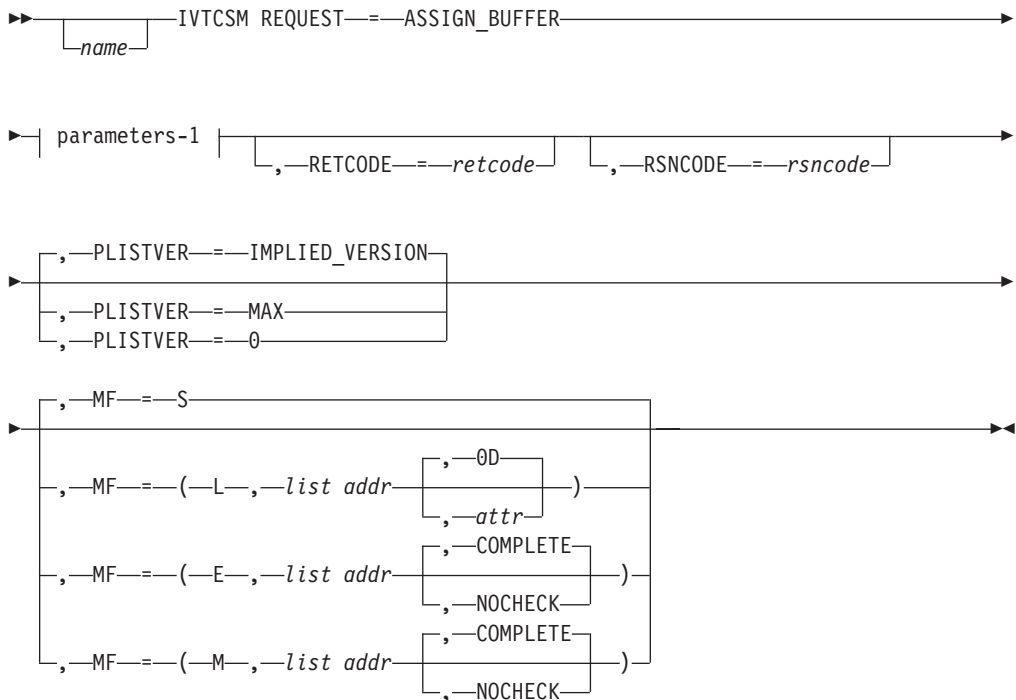

### parameters-1

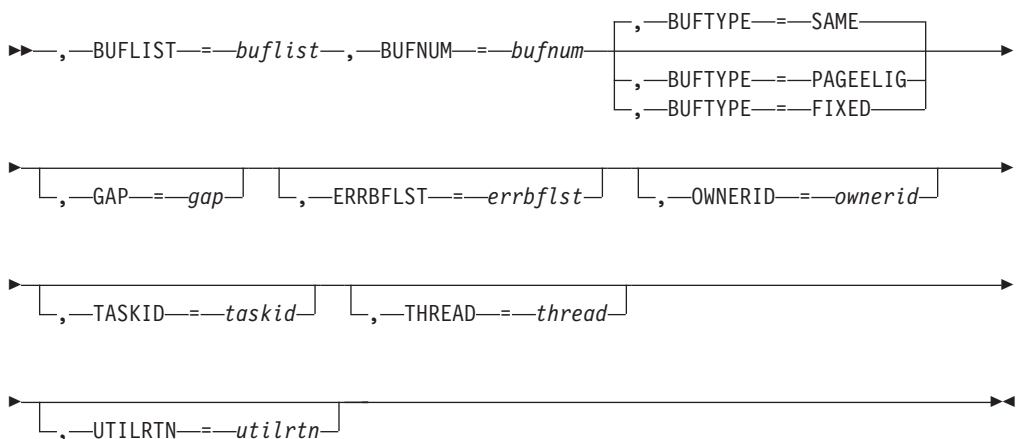

## Parameters

*name*

An optional symbol, starting in column 1, that is the name on the IVTCSM macro invocation. The name must conform to the rules for an ordinary assembler language symbol.

**,BUFLIST=***buflist*

A required input parameter of an area containing a list of buffer entries. The number of entries in the list is provided by BUFNUM. An entry in the buffer list is mapped by IVTBUFL. Some of the fields defined in IVTBUFL are required as input and some are set by CSM as output fields.

**Note:** The buffer token representing the new buffer image is returned in the BUFL\_TOKEN field as output.

The following fields in IVTBUFL are required input for this request.

- BUFL\_VERSION
- BUFL\_TOKEN

The following fields in IVTBUFL are returned as output by CSM for this request.

- BUFL\_TYPE
- BUFL\_TOKEN

To code, specify the RS-type address, or address in register (2)-(12), of a field.

**,BUFNUM=***bufnum*

A required input parameter, specifying the number of buffers to be logically assigned.

To code, specify the RS-type address, or address in register (2)-(12), of a fullword field.

**,BUFTYPE=**

An optional parameter, specifying whether the buffer images are guaranteed to be fixed, eligible to be made pageable or have the same pageable state as the buffers represented by the input token. The default is BUFTYPE=SAME.

**,BUFTYPE=SAME**

Indicates that the pageable state of the buffer images is the same as the buffers represented by the input token.

**,BUFTYPE=PAGEELIG**

Indicates that the buffer images are eligible to be made pageable.

**,BUFTYPE=FIXED**

Indicates that buffer images are guaranteed to be fixed.

**,ERRBFLST=***errbflst*

An optional output parameter, specifying the number of the last buffer entry that was successfully processed when an error is detected during processing of the macroinstruction.

To code, specify the RS-type address, or address in register (2)-(12), of a fullword field.

**,GAP=***gap*

An optional input parameter, specifying the number of bytes used to separate buffer entries. This parameter allows the buffer entries to be in discontinuous storage. If GAP is not specified, buffer entries are contiguous.

To code, specify the RS-type address, or address in register (2)-(12), of a fullword field.

**,MF=**

An optional input parameter that specifies the macro form.

**MF=S** Specifies the standard form of the macro, which builds an inline parameter list and generates the macro invocation to transfer control to the service. MF=S is the default.

**MF=L** Specifies the list form of the macro. Use the list form together with the execute form of the macro for applications that require reentrant code. The list form defines an area of storage that the execute form uses to store the parameters. Only the PLISTVER parameter can be coded with the list form of the macro.

**MF=E** Specifies the execute form of the macro. Use the execute form together with the list form of the macro for applications that require reentrant code. The execute form of the macro stores the parameters into the storage area defined by the list form, and generates the macro invocation to transfer control to the service.

**MF=M**

Use together with the list and execute forms of the macro for service routines that need to provide different options according to user-provided input. Use the list form to define a storage area; use the modify form to set the appropriate options; then use the execute form to call the service.

**,list addr**

The name of a storage area to contain the parameters. For MF=S, MF=E, and MF=M, this can be an RS-type address or an address in register (1)-(12).

**,attr**

An optional input string 1 - 60 characters in length that you use to force boundary alignment of the parameter list. Use a value of 0F to force the parameter list to a word boundary or 0D to force the parameter list to a doubleword boundary. If you do not code *attr*, the system provides a value of 0D.

**,COMPLETE**

Specifies that the system is to check for required parameters and supply defaults for omitted optional parameters.

**,NOCHECK**

Specifies that the system is not to check for required parameters and is not to supply defaults for omitted optional parameters.

**Guidelines:** Use the modify and execute forms of IVTCSM in the following order:

1. Use IVTCSM ...MF=(M,list-addr,COMPLETE) specifying appropriate parameters, including all required ones.
2. Use IVTCSM ...MF=(M,list-addr,NOCHECK), specifying the parameters that you want to change.
3. Use IVTCSM ...MF=(E,list-addr,NOCHECK), to execute the macro.

**,OWNERID=ownerid**

An optional input parameter, specifying the owner to which the buffer image is to be logically assigned. If not coded, the ASID of the issuing application is assigned as the OWNERID.

To code, specify the RS-type address, or address in register (2)-(12), of a halfword field.

**,PLISTVER=**

An optional input parameter that specifies the version of the macro. PLISTVER determines which parameter list the system generates. PLISTVER is an optional input parameter on all forms of the macro, including the list form. When using PLISTVER, specify it on all macro forms used for a request and with the same value on all of the macro forms. The values are:

**IMPLIED\_VERSION**

The lowest version that allows all parameters specified on the request to be processed. If you omit the PLISTVER parameter, IMPLIED\_VERSION is the default.

**MAX** Code this if you want the parameter list to be the largest size currently possible. This size might increase from release to release and affect the amount of storage that your program needs.

If you can tolerate the size change, you should always specify PLISTVER=MAX on the list form of the macro. Specifying MAX ensures that the list-form parameter list is always long enough to hold all the parameters you might specify on the execute form. In this way, MAX ensures that the parameter list does not overwrite nearby storage.

**0** Code this if you use the currently available parameters.

To code, specify one of the following values:

- IMPLIED\_VERSION
- MAX
- A decimal value of 0

**,RETCODE=retcode**

An optional output parameter into which the return code is to be copied from GPR 15.

To code, specify the RS-type address of a fullword field, or register (2)-(12).

**,RSNCODE=rsncode**

An optional output parameter into which the reason code is to be copied from GPR 0.

To code, specify the RS-type address of a fullword field, or register (2)-(12).

**,TASKID=taskid**

An optional input parameter that is to contain the address of a TCB. This further qualifies the ownership of a buffer to a specific task. If TASKID is not specified, the buffer is not associated with a task but is instead associated with the issuing application's ASID.

To code, specify the RS-type address, or address in register (2)-(12), of a pointer field.

**,THREAD=thread**

An optional input parameter, specifying a unique identifier that is placed in the CSM trace entry to correlate trace records with the application that is

requesting the buffers. It is the CSM user's responsibility to ensure that this value is different from the THREAD value specified by other users of the CSM. This can be achieved by specifying an ECSA control block for THREAD.

To code, specify the RS-type address, or address in register (2)-(12), of a 4-character field.

**,UTILRTN=utilrtn**

An optional input parameter that is issued from a utility routine. Specify the utility routine caller's address to be placed in the CSM trace entry. If this parameter is omitted, only the address of the CSM request issuer is placed in the CSM trace entry. This parameter is relevant only to the tracing process. It should be specified only if the CSM user requires identification of the caller of a utility routine in the CSM trace entry.

To code, specify the RS-type address, or address in register (2)-(12), of a fullword field.

## Return codes

The following codes can be returned to the application on this macroinstruction.

### Return code

#### Meaning

- 0 Request completed successfully.
- 4 Request did not complete successfully. See the following reason codes to determine the type of error encountered:

#### Reason code

##### Meaning

- 2 Requested function not supported at the present time, service has not been initialized.
- 7 Buffer token specified is not valid.
- 8 Instance ID in the input buffer token does not match that of the buffer, possible attempt to use a buffer that has been freed.
- 9 Real storage unavailable to provide a fixed buffer, wait not requested.
- 15 Assign buffer request failed because the state of the buffer is guaranteed to be pageable.
- 20 BUFTYPE value specified is not valid for this request.
- 26 Assign buffer request failed because CSM reached the maximum number of image buffers of the single CSM buffer.
- 8 System error while processing the request. See the following reason codes to determine the type of error encountered:

#### Reason code

##### Meaning

- 1 Unable to obtain storage for request.
- 6 An abend occurred while processing this request.



# IVTCSM REQUEST=CHANGE\_OWNER

## Purpose

This macroinstruction allows the application to change the ownership of a buffer to another user.

## Usage

This macroinstruction can be used to assume ownership of another user's buffers or to pass ownership to another user. The new owner must have sufficient information to address the buffers. This information can be found in the CSM buffer list. The owner of a set of buffers bears the responsibility for returning them to CSM on the "IVTCSM REQUEST=FREE\_BUFFER" on page 56 macroinstruction.

CSM associates a set of buffers that have been retrieved from a buffer pool with the OWNERID of an application. The OWNERID is the same as the application's ASID. Ownership of a buffer can be optionally qualified by specifying the TASKID parameter on the macroinstruction. The TASKID is a TCB address with the default being no task association.

Ownership of a buffer that has an associated buffer return exit is not actually changed due to an IVTCSM REQUEST=CHANGE\_OWNER macroinstruction; the buffer is actually borrowed. The original owner of the buffer is maintained so that ownership is restored when the buffer is freed. However, if the original owner's address space terminates before the buffer return exit is invoked, then buffers are returned to CSM.

See "Ownership of buffers" on page 10 for more information.

## Syntax

### main diagram

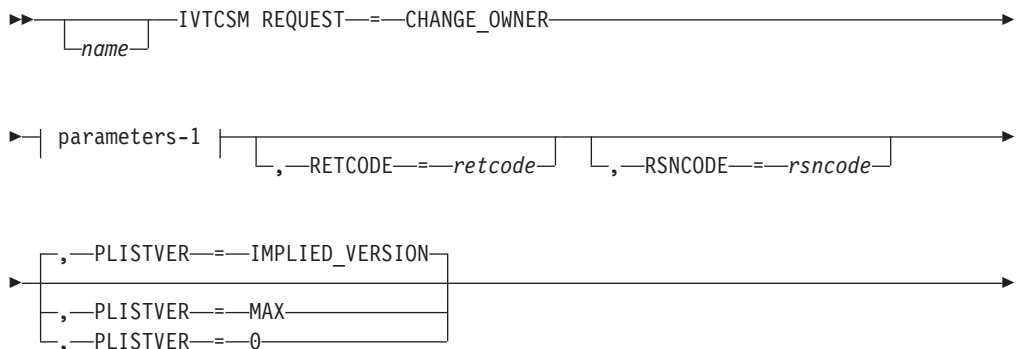

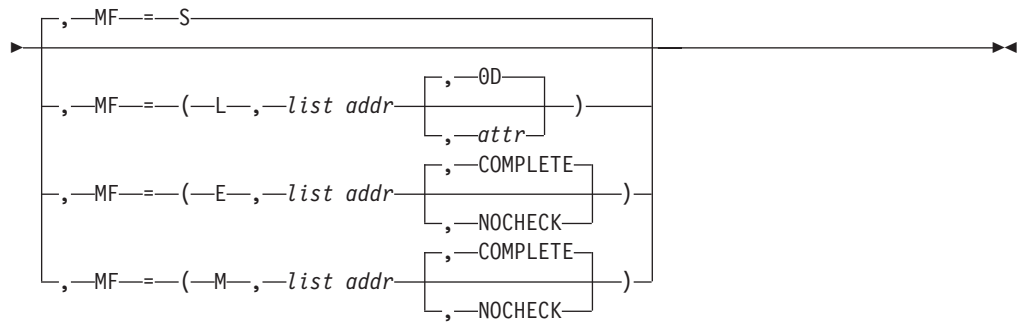

### parameters-1

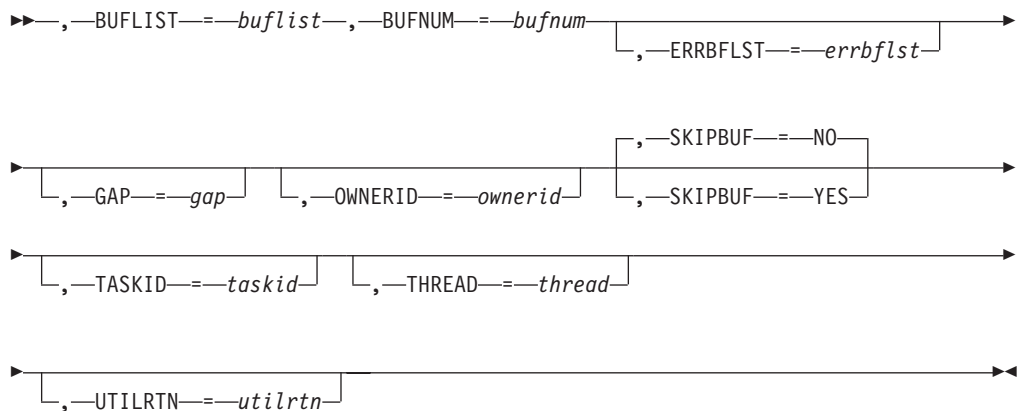

## Parameters

### *name*

An optional symbol, starting in column 1, that is the name on the IVTCSM macro invocation. The name must conform to the rules for an ordinary assembler language symbol.

### **,BUFLIST=buflist**

A required input parameter of an area containing a list of buffer entries. The number of entries in the list is provided by BUFNUM. Each entry in the buffer list is mapped by IVTBUFL.

The following fields in IVTBUFL are required for this request.

- BUFL\_VERSION
- BUFL\_SOURCE

**Rule:** This field is required only when SKIPBUF=YES is specified.

- BUFL\_TOKEN

No fields in IVTBUFL are returned as output by CSM for this request.

To code, specify the RS-type address, or address in register (2)-(12), of a field.

### **,BUFNUM=bufnum**

A required input parameter, specifying the number of buffers to change ownership.

To code, specify the RS-type address, or address in register (2)-(12), of a fullword field.

**,ERRBFLST=errbflst**

An optional output parameter containing the number of the last buffer entry that was successfully processed when an error is detected during processing of the macroinstruction.

To code, specify the RS-type address, or address in register (2)-(12), of a fullword field.

**,GAP=gap**

An optional input parameter, specifying the number of bytes used to separate buffer entries. This parameter allows the buffer entries to be in discontinuous storage. If GAP is not specified, buffer entries are contiguous.

To code, specify the RS-type address, or address in register (2)-(12), of a fullword field.

**,MF=**

An optional input parameter that specifies the macro form.

**MF=S** Specifies the standard form of the macro, which builds an inline parameter list and generates the macro invocation to transfer control to the service. MF=S is the default.

**MF=L** Specifies the list form of the macro. Use the list form together with the execute form of the macro for applications that require reentrant code. The list form defines an area of storage that the execute form uses to store the parameters. Only the PLISTVER parameter can be coded with the list form of the macro.

**MF=E** Specifies the execute form of the macro. Use the execute form together with the list form of the macro for applications that require reentrant code. The execute form of the macro stores the parameters into the storage area defined by the list form, and generates the macro invocation to transfer control to the service.

**MF=M**

Use together with the list and execute forms of the macro for service routines that need to provide different options according to user-provided input. Use the list form to define a storage area; use the modify form to set the appropriate options; then use the execute form to call the service.

**,list addr**

The name of a storage area to contain the parameters. For MF=S, MF=E, and MF=M, this can be an RS-type address or an address in register (1)-(12).

**,attr**

An optional input string 1 - 60 characters in length that forces boundary alignment of the parameter list. Use a value of 0F to force the parameter list to a word boundary or 0D to force the parameter list to a doubleword boundary. If you do not code *attr*, the system provides a value of 0D.

**,COMPLETE**

Specifies that the system is to check for required parameters and supply defaults for omitted optional parameters.

**,NOCHECK**

Specifies that the system is not to check for required parameters and is not to supply defaults for omitted optional parameters.

**Guidelines:** Use the modify and execute forms of IVTCSM in the following order:

1. Use IVTCSM ...MF=(M,list-addr,COMPLETE), specifying appropriate parameters, including all required ones.
2. Use IVTCSM ...MF=(M,list-addr,NOCHECK), specifying the parameters that you want to change.
3. Use IVTCSM ...MF=(E,list-addr,NOCHECK), to execute the macro.

**,OWNERID=ownerid**

An optional input parameter, specifying the owner to which the buffer is to be assigned. If not coded, the ASID of the issuing application is assigned as the OWNERID.

To code, specify the RS-type address, or address in register (2)-(12), of a halfword field.

**,PLISTVER=**

An optional input parameter that specifies the version of the macro. PLISTVER determines which parameter list the system generates. PLISTVER is an optional input parameter on all forms of the macro, including the list form. When using PLISTVER, specify it on all macro forms used for a request and with the same value on all of the macro forms. The values are:

**IMPLIED\_VERSION**

The lowest version that allows all parameters specified on the request to be processed. If you omit the PLISTVER parameter, IMPLIED\_VERSION is the default.

**MAX** Code this if you want the parameter list to be the largest size currently possible. This size might increase from release to release and affect the amount of storage that your program needs.

If you can tolerate the size change, it is recommended that you always specify PLISTVER=MAX on the list form of the macro. Specifying MAX ensures that the list-form parameter list is always long enough to hold all the parameters you might specify on the execute form; in this way, MAX ensures that the parameter list does not overwrite nearby storage.

**0** Code this if you use the currently available parameters.

To code, specify one of the following values:

- IMPLIED\_VERSION
- MAX
- A decimal value of 0

**,RETCODE=retcode**

An optional output parameter into which the return code is to be copied from GPR 15.

To code, specify the RS-type address of a fullword field, or register (2)-(12).

**,RSNCODE=rsncode**

An optional output parameter into which the reason code is to be copied from GPR 0.

To code, specify the RS-type address of a fullword field, or register (2)-(12).

**,SKIPBUF=**

An optional parameter, specifying whether all entries in the buffer list should be processed. The default is SKIPBUF=NO.

**,SKIPBUF=NO**

Specifies that all the entries in the buffer list are processed. No entries are skipped. The BUFL\_SOURCE value is not examined.

**,SKIPBUF=YES**

Specifies that the only entries in the buffer list that have a BUFL\_SOURCE value indicating the user's non-CSM storage (BUFL\_UDSPACE or BUFL\_USTOR) is skipped.

**,TASKID=*taskid***

An optional input parameter that is to contain the address of a TCB. This further qualifies the ownership of a buffer to a specific task. If TASKID is not specified, the buffer is not associated with a task but is instead associated with the issuing application's ASID.

To code, specify the RS-type address, or address in register (2)-(12), of a pointer field.

**,THREAD=*thread***

An optional input parameter, specifying a unique identifier that is placed in the CSM trace entry to correlate trace records with the application that is requesting the buffers. It is the CSM user's responsibility to ensure that this value is different from the THREAD value specified by other users of the CSM. One way this can be achieved is by specifying an ECSA control block for THREAD.

To code, specify the RS-type address, or address in register (2)-(12), of a 4-character field.

**,UTILRTN=*utilrtn***

An optional input parameter that is issued from a utility routine. Specify the utility routine caller's address to be placed in the CSM trace entry. If this parameter is omitted, only the address of the CSM request issuer is placed in the CSM trace entry. This parameter is relevant only to the tracing process. It should be specified only if the CSM user requires identification of the caller of a utility routine in the CSM trace entry.

To code, specify the RS-type address, or address in register (2)-(12), of a fullword field.

## Return codes

The following codes can be returned to the application on this macroinstruction:

### Return code

#### Meaning

- 0 Request completed successfully.
- 4 Request did not complete successfully. See the following reason codes to determine the type of error encountered.

#### Reason code

##### Meaning

- 2 Requested function not supported at the present time, service has not been initialized.
- 7 The specified buffer token is not valid.
- 8 Instance ID in the input buffer token does not match that of the buffer, possible attempt to use a buffer that has been freed.

## IVTCSM REQUEST=COPY\_DATA

### Purpose

Use this macroinstruction to copy data to or from a CSM buffer or a user data area.

### Usage

This macroinstruction assists the application by isolating it from possible storage key differences between that of the requester and that of the CSM buffer. It also assists users of CSM data space buffers by isolating the requester from the addressing method used to access a data space.

This macroinstruction allows multiple source buffers to be copied to or from one or multiple target buffers. The source buffers are copied to the target buffers using the source and target buffer lengths to pack data or span data across the target buffers as required.

If the cumulative length of the source buffers is greater than the cumulative length of the target buffers, the source data is truncated. The application can specify a character on the PADCHAR input parameter to pad the target buffers when the cumulative length of the source buffers is less than the cumulative length of the target buffers.

CSM accepts a source buffer list and a target buffer list as input. This is the same buffer list that is mapped by the IVTBUFL DSECT that is described on page “CSM buffer list entry (IVTBUFL)” on page 81. The number of entries in each list are not required to be equal. Within each list, entries might or might not represent a CSM buffer. The BUFL\_SOURCE field in the entry indicates whether the entry represents a CSM buffer. For entries representing CSM buffers, the address that is the source or target of the copy is supplied by the requester and is not required to be the actual start address of the CSM buffer. CSM validates that the specified address and length corresponds to a storage area that is within the bounds of the CSM buffer. This validation is based on the size of the buffer as determined at the time the buffer pool was created.

The application can use the COPY\_DATA request to copy data to or from a non-CSM data space using the ALET provided in the buffer list entry. The ALET must be valid for the address space for which it is being used.

### Syntax

#### main diagram

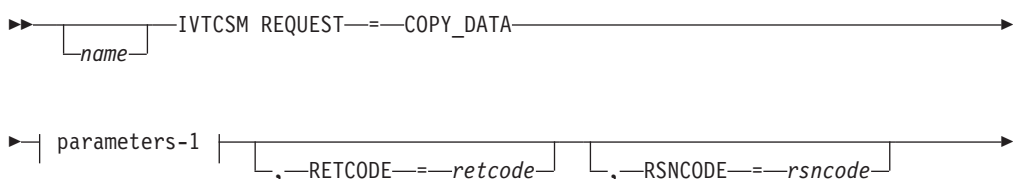

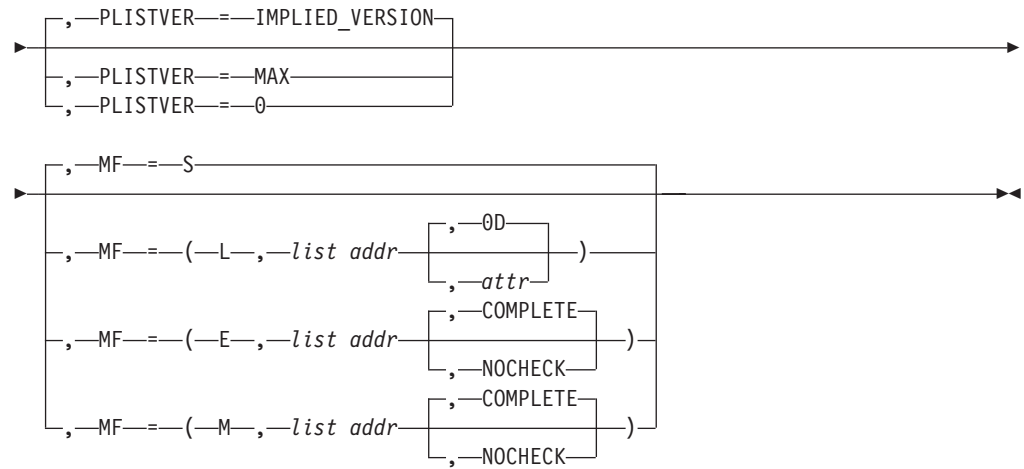

### parameters-1

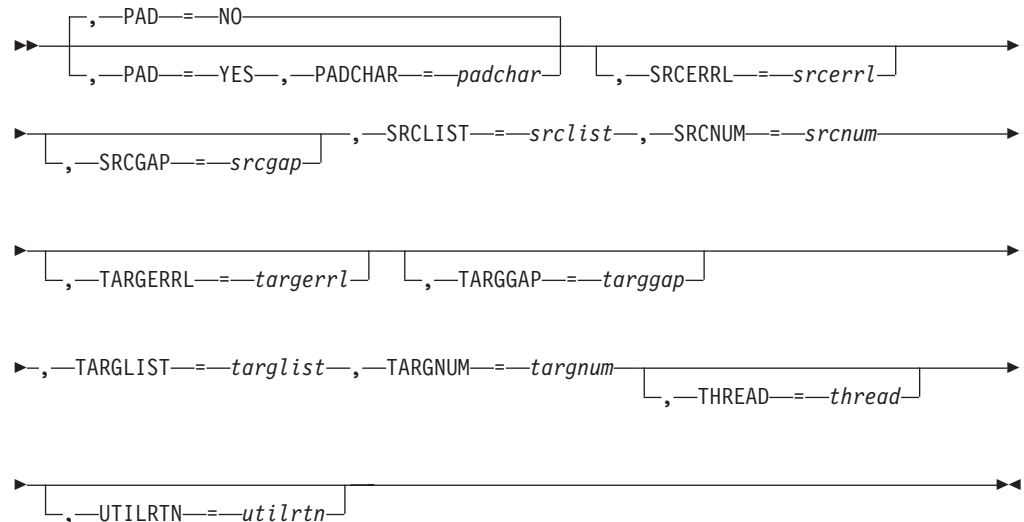

## Parameters

### *name*

An optional symbol, starting in column 1, that is the name on the IVTCSM macro invocation. The name must conform to the rules for an ordinary assembler language symbol.

### **,MF=**

An optional input parameter that specifies the macro form.

**MF=S** Specifies the standard form of the macro, which builds an inline parameter list and generates the macro invocation to transfer control to the service. MF=S is the default.

**MF=L** Specifies the list form of the macro. Use the list form together with the execute form of the macro for applications that require reentrant code. The list form defines an area of storage that the execute form uses to store the parameters. Only the PLISTVER parameter can be coded with the list form of the macro.

**MF=E** Specifies the execute form of the macro. Use the execute form together with the list form of the macro for applications that require reentrant code. The execute form of the macro stores the parameters into the storage area defined by the list form, and generates the macro invocation to transfer control to the service.

**MF=M**

Use together with the list and execute forms of the macro for service routines that need to provide different options according to user-provided input. Use the list form to define a storage area; use the modify form to set the appropriate options; then use the execute form to call the service.

**,list addr**

The name of a storage area to contain the parameters. For MF=S, MF=E, and MF=M, this can be an RS-type address or an address in register (1)-(12).

**,attr**

An optional input string 1 - 60 characters in length that you use to force boundary alignment of the parameter list. Use a value of 0F to force the parameter list to a word boundary, or 0D to force the parameter list to a doubleword boundary. If you do not code *attr*, the system provides a value of 0D.

**,COMPLETE**

Specifies that the system is to check for required parameters and supply defaults for omitted optional parameters.

**,NOCHECK**

Specifies that the system is not to check for required parameters and is not to supply defaults for omitted optional parameters.

**Guidelines:**

Use the modify and execute forms of IVTCSM in the following order:

1. Use IVTCSM ...MF=(M,list-addr,COMPLETE) specifying appropriate parameters, including all required ones.
2. Use IVTCSM ...MF=(M,list-addr,NOCHECK), specifying the parameters that you want to change.
3. Use IVTCSM ...MF=(E,list-addr,NOCHECK), to execute the macro.

**,PAD=**

An optional parameter that indicates if padding is to be performed. The default is PAD=NO.

**,PAD=NO**

Indicates that padding is not performed.

**,PAD=YES**

Indicates that padding is to be performed using the value specified by PADCHAR.

**,PADCHAR=padchar**

When PAD=YES is specified, a required input parameter, specifying the character to use as pad if the cumulative target length is greater than the cumulative source length. If PAD=YES is not specified, then no padding is performed.

To code, specify the RS-type address, or address in register (2)-(12), of a 1-character field.



**,PLISTVER=**

An optional input parameter that specifies the version of the macro. PLISTVER determines which parameter list the system generates. PLISTVER is an optional input parameter on all forms of the macro, including the list form. When using PLISTVER, specify it on all macro forms used for a request and with the same value on all of the macro forms.

The values are:

**IMPLIED\_VERSION**

The lowest version that allows all parameters specified on the request to be processed. If you omit the PLISTVER parameter, IMPLIED\_VERSION is the default.

**MAX** Specify when you want the parameter list to be the largest size currently possible. This size might increase from release to release and affect the amount of storage that your program needs. If you can tolerate the size change, you should always specify PLISTVER=MAX on the list form of the macro. Specifying MAX ensures that the list-form parameter list is always long enough to hold all the parameters you might specify on the execute form; in this way, MAX ensures that the parameter list does not overwrite nearby storage.

**0** Specify when you use the currently available parameters.

To code, specify one of the following values:

- IMPLIED\_VERSION
- MAX
- A decimal value of 0

**,RETCODE=*retcode***

An optional output parameter into which the return code is to be copied from GPR 15.

To code, specify the RS-type address of a fullword field, or register (2)-(12).

**,RSNCODE=*rsncode***

An optional output parameter into which the reason code is to be copied from GPR 0.

To code, specify the RS-type address of a fullword field, or register (2)-(12).

**,SRCERRL=*srcerrl***

An optional output parameter, specifying the number of the last buffer entry that was successfully processed in the SRCLIST.

To code, specify the RS-type address, or address in register (2)-(12), of a fullword field.

**,SRCGAP=*srcgap***

An optional input parameter, specifying the number of bytes used to separate buffer entries in SRCLIST. This parameter allows the buffer entries to be in discontinuous storage. If this parameter is not specified, buffer entries are in contiguous storage.

To code, specify the RS-type address, or address in register (2)-(12), of a fullword field.

**,SRCLIST=*srclist***

A required input parameter of an area containing a list of information about the buffers from which the data is to be copied. Each entry in the list describes

a buffer and is mapped by IVTBUFL. The number of entries is equal to the number of buffers specified by SRCNUM. The buffer entry can represent a CSM buffer or a user data area.

The following fields in IVTBUFL are required as input for this request.

- BUFL\_VERSION
- BUFL\_SOURCE
- BUFL\_TOKEN (Required only if data is being copied from a CSM buffer.)
- BUFL\_ALET ( Required only if required to access the data in a user data space.)
- BUFL\_ADDR
- BUFL\_SIZE

To code, specify the RS-type address, or address in register (2)-(12), of a field.

**,SRCNUM=srcnum**

A required input parameter, specifying the number of source buffers for the copy.

To code, specify the RS-type address, or address in register (2)-(12), of a fullword field.

**,TARGERRL=targerrl**

An optional output parameter, specifying the number of the last buffer entry that was successfully processed in the TARGLIST. To code, specify the RS-type address, or address in register (2)-(12), of a fullword field.

**,TARGGAP=targgap**

An optional input parameter, specifying the number of bytes used to separate buffer entries in TARGLIST. This parameter allows the buffer entries to be in discontinuous storage. If this parameter is not specified, buffer entries are in contiguous storage.

To code, specify the RS-type address, or address in register (2)-(12), of a fullword field.

**,TARGLIST=targlist**

A required input parameter of an area containing a list of information about the buffers that are the target of the copy operation. Each entry in the list is a buffer entry mapped by IVTBUFL. The buffer entry can represent a CSM buffer or a user data area.

The following fields in IVTBUFL are required as input for this request.

- BUFL\_VERSION
- BUFL\_SOURCE
- BUFL\_TOKEN (Required only if data is being copied into a CSM buffer.)
- BUFL\_ALET (Required only if required to copy data into a user data space.)
- BUFL\_ADDR
- BUFL\_SIZE

No fields in IVTBUFL are returned as output, by CSM, for this request.

To code, specify the RS-type address, or address in register (2)-(12), of a field.

**,TARGNUM=targnum**

A required input parameter, specifying the number of target buffers for the copy.

To code, specify the RS-type address, or address in register (2)-(12), of a fullword field.

**,THREAD=thread**

An optional input parameter, specifying a unique identifier that is placed in the CSM trace entry to correlate trace records with the application that is requesting the buffers. It is the CSM user's responsibility to ensure that this value is different from the THREAD value specified by other users of the CSM. One way this can be achieved is by specifying an ECSA control block for THREAD.

To code, specify the RS-type address, or address in register (2)-(12), of a 4-character field.

**,UTILRTN=utilrtn**

An optional input parameter that is issued from a utility routine. Specify the utility routine caller's address to be placed in the CSM trace entry. If this parameter is omitted, only the address of the CSM request issuer is placed in the CSM trace entry. This parameter is relevant only to the tracing process. It should be specified only if the CSM user requires identification of the caller of a utility routine in the CSM trace entry.

To code, specify the RS-type address, or address in register (2)-(12), of a fullword field.

## Return codes

The following codes can be returned to the application on this macroinstruction:

### Return code

#### Meaning

- 0 Request completed successfully.
- 4 Request did not complete successfully. See the following reason codes to determine the type of error encountered.

### Reason code

#### Meaning

- 2 Requested function not supported at the present time, service has not been initialized.
- 7 Invalid buffer token specified.
- 8 Instance ID in the input buffer token does not match that of the buffer, possible attempt to use a buffer that has been freed.
- 12 Address and length specified on a copy data request for a source buffer descriptor is outside the bounds of the CSM buffer represented by the specified pool token.
- 13 Address and length specified on a copy data request for a target buffer descriptor is outside the bounds of the CSM buffer represented by the specified pool token.
- 14 Copy operation resulted in truncation of source data due to insufficient buffer space provided by the target buffer list.
- 18 BUFL\_SOURCE value is not valid for an entry in the Source buffer list (SRCLIST).
- 19 BUFL\_SOURCE value is not valid for an entry in the Target buffer list (TRGLIST).

- 20 BUFTYPE value specified is not valid for this request.
- 21 BUFSOURC value specified is not valid for this request.
- 22 Source and target buffers overlap, no data has been copied.

## IVTCSM REQUEST=CREATE\_POOL

### Purpose

Use this macroinstruction to allow the user to register as a user of a storage pool of buffers residing in ECSA or in a data space.

The structures to maintain the storage pools are created in response to the first CREATE\_POOL request by a user of CSM. For storage pools requesting a data space as the storage type, a data space is created on the first request for a pool of this type. Multiple storage pools can exist per data space. Data space storage pools are further qualified as 31-bit backed (when fixed, the real storage frame containing the page is below the 2-gigabyte real storage bar) or 64-bit backed (when fixed, the real storage frame containing the page can be on or above the 2-gigabyte real storage bar). If a 64-bit backed pool is requested and cannot be created because the machine is not executing in z/Architecture® mode, the request is converted to a 31-bit backed request for the corresponding pool size.

On the create request, the caller specifies the size of the buffers in the pool to be created (4096, 16384, 32768, 61440, and 184320), and for dataspace pools, whether or not the pool is 31-bit backed or 64-bit backed. Only one pool of a given size exists per storage type. Requests by other callers for a pool of the same characteristics share the existing pool. The EXPBUF, INITBUF, and MINFREE values for each pool are each set to the largest value specified by any single user sharing a pool. Therefore, these values can also be adjusted downward when a user discontinues sharing a pool (that is, the user issues a DELETE\_POOL request).

### Usage

This macroinstruction should be used by an application if it subsequently requests buffers from CSM.

### Environment

This macroinstruction must be issued in task mode; it is not allowed in cross memory mode.

### Syntax

#### main diagram

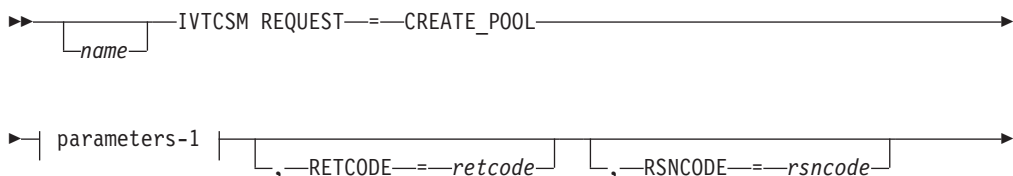

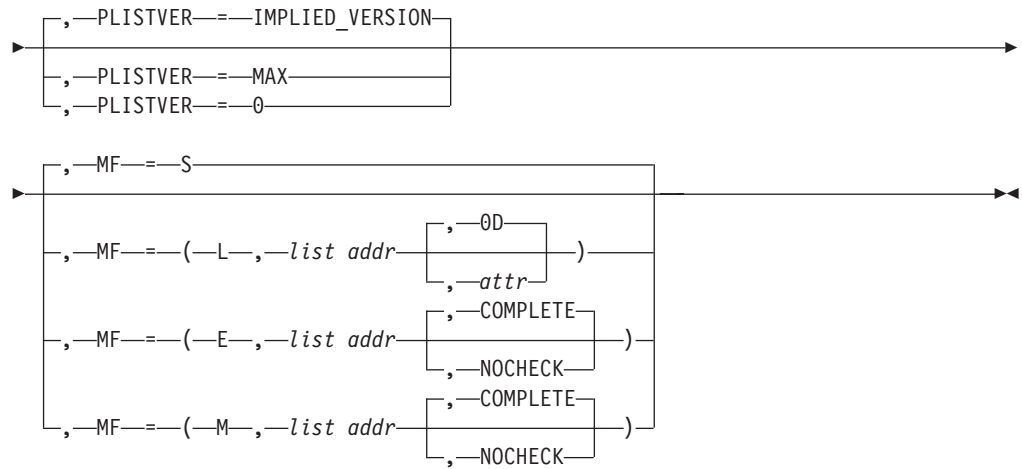

### parameters-1

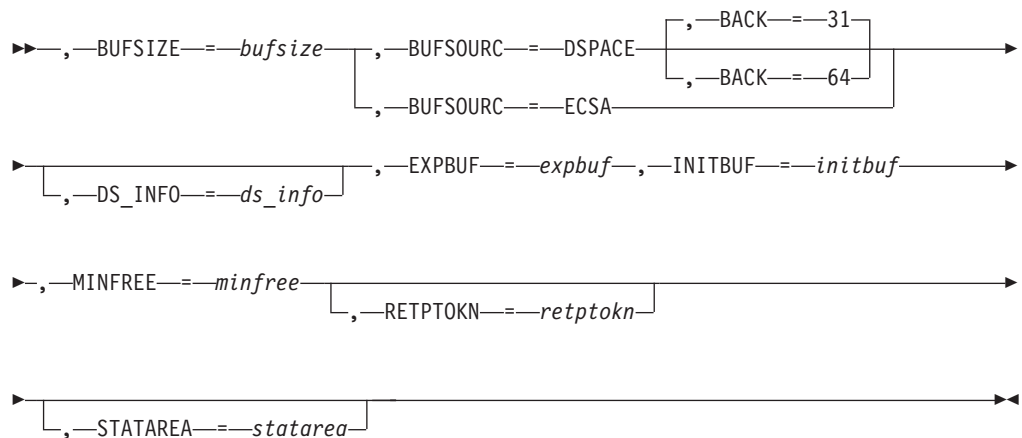

## Parameters

### *name*

An optional symbol, starting in column 1, that is the name on the IVTCSM macro invocation. The name must conform to the rules for an ordinary assembler language symbol.

### **,BACK=location**

An optional parameter that applies to BUFSOURCE=DSPACE. Specifies whether or not the data space storage, when fixed, can be backed above the 2-gigabyte real storage bar. BACK=31 forces the storage to be backed below the 2-gigabyte bar and BACK=64 allows the storage to be backed on or above the 2-gigabyte bar. BACK=31 is the default. If a 64-bit backed pool is requested and cannot be created because the machine is not executing in z/Architecture mode, the request is converted to a 31-bit backed request for the corresponding pool size.

### **,BUFSIZE=bufsize**

A required input parameter, specifying the size of the buffers in the pool to be created. Valid pool sizes are 4096, 16384, 32768, 61440, and 184320. All other

values specified on this parameter are rounded up to the next valid pool size. However, if BUFSIZE is greater than 184320, the CREATE\_POOL request is rejected.

To code, specify the RS-type address, or address in register (2)-(12), of a fullword field.

**,BUFSOURC=**

A required parameter, specifying the source of the storage from which the buffers are to be allocated.

**,BUFSOURC=DSPACE**

Indicates that the storage pool is to be created in data space.

**,BUFSOURC=ECSA**

Indicates that the storage pool is to be created in ECSA.

**,DS\_INFO=ds\_info**

An optional output parameter that contains the address of an area containing the information required to dump CSM data spaces mapped by IVTDATSP.

To code, specify the RS-type address, or address in register (2)-(12), of a pointer field.

**,EXPBUF=expbuf**

A required input parameter, specifying the number of buffers by which the pool is expanded when the number of free buffers falls below the value for MINFREE or when a GET\_BUFFER request needs to be satisfied.

Valid ranges for EXPBUF are listed in Table 3. If a value outside of a range is specified, then CSM uses a default value. The default values for EXPBUF are also listed in Table 3.

Table 3. Default values for EXPBUF

Pool size	Valid range	Default
4096	1 - 256	16
16384	1 - 256	8
32768	1 - 128	4
61440	1 - 68	4
184320	1 - 22	2

To code, specify the RS-type address, or address in register (2)-(12), of a fullword field.

**,INITBUF=initbuf**

A required input parameter, specifying the initial number of buffers to be created in the storage pool. If 0 is specified, the base pool is created only to represent the requester as a user of the pool. In this case, the pool is expanded on the first GET\_BUFFER macroinstruction based on the specification for EXPBUF.

**Guideline:** The pool does not contract if the number of buffers currently available is below a certain value. The value is determined as the higher of INITBUF or MINFREE+(2\*EXPBUF).

Valid values for INITBUF are in the range 0 - 9999. If a value outside of this range is specified, then CSM uses a default value. The default values for INITBUF are listed Table 4 on page 43.

Table 4. Default values for INITBUF

Pool size	Default
4096	64
16384	32
32768	16
61440	16
184320	2

To code, specify the RS-type address, or address in register (2)-(12), of a fullword field.

**,MF=**

An optional input parameter that specifies the macro form.

**MF=S** Specifies the standard form of the macro, which builds an inline parameter list and generates the macro invocation to transfer control to the service. MF=S is the default.

**MF=L** Specifies the list form of the macro. Use the list form together with the execute form of the macro for applications that require re-entrant code. The list form defines an area of storage that the execute form uses to store the parameters. Only the PLISTVER parameter can be coded with the list form of the macro.

**MF=E** Specifies the execute form of the macro. Use the execute form together with the list form of the macro for applications that require re-entrant code. The execute form of the macro stores the parameters into the storage area defined by the list form, and generates the macro invocation to transfer control to the service.

**MF=M**

Use together with the list and execute forms of the macro for service routines that need to provide different options according to user-provided input. Use the list form to define a storage area; use the modify form to set the appropriate options; then use the execute form to call the service.

**,list addr**

The name of a storage area to contain the parameters. For MF=S, MF=E, and MF=M, this can be an RS-type address or an address in register (1)-(12).

**,attr**

An optional input string 1 - 60 characters in length that you use to force boundary alignment of the parameter list. Use a value of 0F to force the parameter list to a word boundary, or 0D to force the parameter list to a doubleword boundary. If you do not code *attr*, the system provides a value of 0D.

**,COMPLETE**

Specifies that the system is to check for required parameters and supply defaults for omitted optional parameters.

**,NOCHECK**

Specifies that the system is not to check for required parameters and is not to supply defaults for omitted optional parameters.

**Guidelines:** Use the modify and execute forms of IVTCSM in the following order:

1. Use IVTCSM ...MF=(M,list-addr,COMPLETE) specifying appropriate parameters, including all required ones.
2. Use IVTCSM ...MF=(M,list-addr,NOCHECK), specifying the parameters that you want to change.
3. Use IVTCSM ...MF=(E,list-addr,NOCHECK), to execute the macro.

**,MINFREE=***minfree*

A required input parameter, specifying the minimum number of buffers to be free in the pool at any time. The storage pool is expanded if the number of free buffers falls below this limit.

Valid values for MINFREE are in the range 0 - 9999. If a value outside of this range is specified, then CSM uses a default value. The default values for MINFREE are listed in Table 5.

Table 5. Default values for MINFREE

Pool size	Default
4096	8
16384	4
32768	2
61440	2
184320	1

To code, specify the RS-type address, or address in register (2)-(12), of a fullword field.

**,PLISTVER=**

An optional input parameter that specifies the version of the macro. PLISTVER determines which parameter list the system generates. PLISTVER is an optional input parameter on all forms of the macro, including the list form. When using PLISTVER, specify it on all macro forms used for a request and with the same value on all of the macro forms. The values are:

**IMPLIED\_VERSION**

The lowest version that allows all parameters specified on the request to be processed. If you omit the PLISTVER parameter, IMPLIED\_VERSION is the default.

**MAX** Specify when you want the parameter list to be the largest size currently possible. This size might increase from release to release and affect the amount of storage that your program needs.

If you can tolerate the size change, you should always specify PLISTVER=MAX on the list form of the macro. Specifying MAX ensures that the list-form parameter list is always long enough to hold all the parameters you might specify on the execute form; in this way, MAX ensures that the parameter list does not overwrite nearby storage.

**0** Specify when you use the currently available parameters.

To code, specify one of the following values:

- IMPLIED\_VERSION
- MAX



- A decimal value of 0

**,RETCODE=retcode**

An optional output parameter into which the return code is to be copied from GPR 15.

To code, specify the RS-type address of a fullword field, or register (2)-(12).

**,RETPTOKN=retptokn**

An optional output parameter of an area in which the application is to receive a token representing this user of this pool. This token must be supplied as input on the IVTCSM REQUEST=DELETE\_POOL and IVTCSM REQUEST=GET\_BUFFER macroinstructions, with the POOLTOKN parameter associated with this pool.

To code, specify the RS-type address, or address in register (2)-(12), of a 10-character field.

**,RSNCODE=rsncode**

An optional output parameter into which the reason code is to be copied from GPR 0.

To code, specify the RS-type address of a fullword field, or register (2)-(12).

**,STATAREA=statarea**

An optional output parameter that contains the address an area containing the resource statistics mapped by IVTSTATA.

To code, specify the RS-type address, or address in register (2)-(12), of a pointer field.

## Return codes

The following codes can be returned to the application on this macroinstruction:

**Return code**

**Meaning**

- 0 Request completed successfully.
- 4 Request did not complete successfully. See the following reason codes to determine the type of error encountered.

**Reason code**

**Meaning**

- 3 Specified buffer size is large than supported size.
- 4 Buffer pool cannot be expanded to satisfy request.
- 21 BUFSOURC value is not valid for this request.
- 23 Unable to create the specified pool. Creation of the pool would cause the ECSA maximum limit to be exceeded.
- 8 System error while processing the request. See the following reason codes to determine the type of error encountered.

**Reason code**

**Meaning**

- 1 Unable to obtain storage for request.
- 2 Schedule SRB fail for PC routine.
- 3 Unable to create ALET for data space.

- 4 Error encountered while creating the data space.
- 5 Unable to create another data space. Number of data spaces exceeds the maximum.
- 6 An abend occurred while processing this request.

## IVTCSM REQUEST=DELETE\_POOL

### Purpose

Use this macroinstruction to allow the user to indicate that it is no longer a registered user of the storage pool.

Because each pool might have multiple users, a storage pool is not deleted until all buffers have been returned by all users and delete requests have been received for each corresponding create request.

### Usage

This macroinstruction should be used only if an IVTCSM REQUEST=CREATE\_POOL macroinstruction was previously issued by the application.

### Environment

This macroinstruction must be issued in task mode; it is not allowed in cross memory mode.

### Syntax

#### main diagram

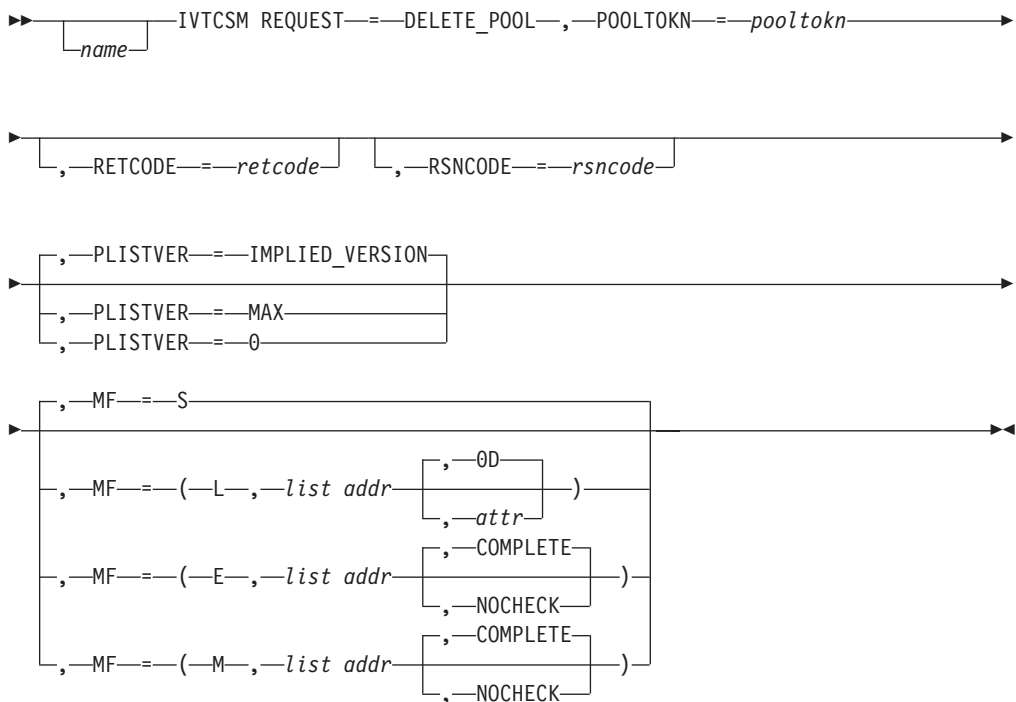

## Parameters

### *name*

An optional symbol, starting in column 1, that is the name on the IVTCSM macro invocation. The name must conform to the rules for an ordinary assembler language symbol.

### **,MF=**

An optional input parameter that specifies the macro form.

**MF=S** Specifies the standard form of the macro, which builds an inline parameter list and generates the macro invocation to transfer control to the service. MF=S is the default.

**MF=L** Specifies the list form of the macro. Use the list form together with the execute form of the macro for applications that require reentrant code. The list form defines an area of storage that the execute form uses to store the parameters. Only the PLISTVER parameter can be coded with the list form of the macro.

**MF=E** Specifies the execute form of the macro. Use the execute form together with the list form of the macro for applications that require reentrant code. The execute form of the macro stores the parameters into the storage area defined by the list form, and generates the macro invocation to transfer control to the service.

### **MF=M**

Use together with the list and execute forms of the macro for service routines that need to provide different options according to user-provided input. Use the list form to define a storage area; use the modify form to set the appropriate options; then use the execute form to call the service.

### **,list addr**

The name of a storage area to contain the parameters. For MF=S, MF=E, and MF=M, this can be an RS-type address or an address in register (1)-(12).

### **,attr**

An optional input string 1 - 60 characters in length that you use to force boundary alignment of the parameter list. Use a value of 0F to force the parameter list to a word boundary, or 0D to force the parameter list to a doubleword boundary. If you do not code *attr*, the system provides a value of 0D.

### **,COMPLETE**

Specifies that the system is to check for required parameters and supply defaults for omitted optional parameters.

### **,NOCHECK**

Specifies that the system is not to check for required parameters and is not to supply defaults for omitted optional parameters.

## Guidelines:

Use the modify and execute forms of IVTCSM in the following order:

1. Use IVTCSM ...MF=(M,list-addr,COMPLETE) specifying appropriate parameters, including all required ones.
2. Use IVTCSM ...MF=(M,list-addr,NOCHECK), specifying the parameters that you want to change.

3. Use IVTCSM ...MF=(E,list-addr,NOCHECK), to execute the macro.

**,PLISTVER=**

An optional input parameter that specifies the version of the macro. PLISTVER determines which parameter list the system generates. PLISTVER is an optional input parameter on all forms of the macro, including the list form. When using PLISTVER, specify it on all macro forms used for a request and with the same value on all of the macro forms. The values are:

**IMPLIED\_VERSION**

The lowest version that allows all parameters specified on the request to be processed. If you omit the PLISTVER parameter, IMPLIED\_VERSION is the default.

**MAX** Specify when you want the parameter list to be the largest size currently possible. This size might increase from release to release and affect the amount of storage that your program needs.

If you can tolerate the size change, you should always specify PLISTVER=MAX on the list form of the macro. Specifying MAX ensures that the list-form parameter list is always long enough to hold all the parameters you might specify on the execute form; in this way, MAX ensures that the parameter list does not overwrite nearby storage.

**0** Specify when you use the currently available parameters.

To code, specify one of the following values:

- IMPLIED\_VERSION
- MAX
- A decimal value of 0

**,POOLTKN=*pooltokn***

A required input parameter of a token representing this user of this pool. This must be the token provided to the application on the associated IVTCSM REQUEST=CREATE\_POOL macroinstruction.

To code, specify the RS-type address, or address in register (2)-(12), of a 10-character field.

**,RETCODE=*retcode***

An optional output parameter into which the return code is to be copied from GPR 15.

To code, specify the RS-type address of a fullword field, or register (2)-(12).

**,RSNCODE=*rsncode***

An optional output parameter into which the reason code is to be copied from GPR 0.

To code, specify the RS-type address of a fullword field, or register (2)-(12).

## Return codes

The following codes can be returned to the application on this macroinstruction:

**Return code**

**Meaning**

- 0** Request completed successfully.
- 4** Request did not complete successfully. See the following reason codes to determine the type of error encountered:

**Reason code**

**Meaning**

- 2 Requested function not supported at the present time, service has not been initialized.
- 6 Pool token specified not valid.
- 8 System error while processing the request.

**Reason code**

**Meaning**

- 6 An abend occurred while processing this request.

## IVTCSM REQUEST=DUMP\_INFO

### Purpose

Use this macroinstruction to request the address of the information required to include CSM data space information in a dump.

### Usage

CSM returns the address of the requested information in the address provided on the DS\_INFO parameter. This information is mapped by the IVTDATSP DSECT as described on page "CSM data space information (IVTDATSP)" on page 83.

### Syntax

#### main diagram

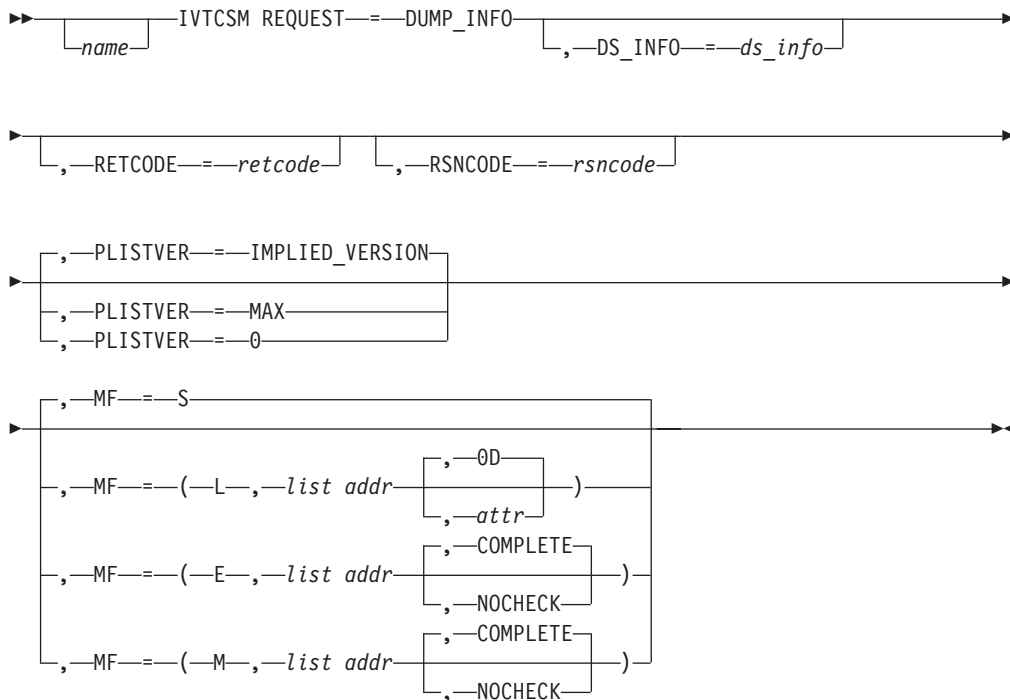

## Parameters

*name*

An optional symbol, starting in column 1, that is the name on the IVTCSM macro invocation. The name must conform to the rules for an ordinary assembler language symbol.

**,DS\_INFO=ds\_info**

An optional output parameter that contains the address of an area containing the information required to dump CSM data spaces mapped by IVTDATSP.

To code, specify the RS-type address, or address in register (2)-(12), of a pointer field.

**,MF=**

An optional input parameter that specifies the macro form.

**MF=S** Specifies the standard form of the macro, which builds an inline parameter list and generates the macro invocation to transfer control to the service. MF=S is the default.

**MF=L** Specifies the list form of the macro. Use the list form together with the execute form of the macro for applications that require reentrant code. The list form defines an area of storage that the execute form uses to store the parameters. Only the PLISTVER parameter can be coded with the list form of the macro.

Use MF=E to specify the execute form of the macro. Use the execute form together with the list form of the macro for applications that require reentrant code. The execute form of the macro stores the parameters into the storage area defined by the list form, and generates the macro invocation to transfer control to the service.

Use MF=M together with the list and execute forms of the macro for service routines that need to provide different options according to user-provided input. Use the list form to define a storage area; use the modify form to set the appropriate options; then use the execute form to call the service.

**,list addr**

The name of a storage area to contain the parameters. For MF=S, MF=E, and MF=M, this can be an RS-type address or an address in register (1)-(12).

**,attr**

An optional input string 1 - 60 characters in length that you use to force boundary alignment of the parameter list. Use a value of 0F to force the parameter list to a word boundary, or 0D to force the parameter list to a doubleword boundary. If you do not code *attr*, the system provides a value of 0D.

**,COMPLETE**

Specifies that the system is to check for required parameters and supply defaults for omitted optional parameters.

**,NOCHECK**

Specifies that the system is not to check for required parameters and is not to supply defaults for omitted optional parameters.

### Guidelines:

Use the modify and execute forms of IVTCSM in the following order:

1. Use IVTCSM ...MF=(M,list-addr,COMPLETE) specifying appropriate parameters, including all required ones.
2. Use IVTCSM ...MF=(M,list-addr,NOCHECK), specifying the parameters that you want to change.
3. Use IVTCSM ...MF=(E,list-addr,NOCHECK), to execute the macro.

**,PLISTVER=**

An optional input parameter that specifies the version of the macro. PLISTVER determines which parameter list the system generates. PLISTVER is an optional input parameter on all forms of the macro, including the list form. When using PLISTVER, specify it on all macro forms used for a request and with the same value on all of the macro forms. The values are:

**IMPLIED\_VERSION**

The lowest version that allows all parameters specified on the request to be processed. If you omit the PLISTVER parameter, IMPLIED\_VERSION is the default.

**MAX** Code this value if you want the parameter list to be the largest size currently possible. This size might increase from release to release and affect the amount of storage that your program needs.

If you can tolerate the size change, always specify PLISTVER=MAX on the list form of the macro. Specifying MAX ensures that the list-form parameter list is always long enough to hold all the parameters you might specify on the execute form; in this way, MAX ensures that the parameter list does not overwrite nearby storage.

**0** Code this value if you use the currently available parameters.

To code, specify one of the following values:

- IMPLIED\_VERSION
- MAX
- A decimal value of 0

**,RETCODE=*retcode***

An optional output parameter into which the return code is to be copied from GPR 15.

To code, specify the RS-type address of a fullword field, or register (2)-(12).

**,RSNCODE=*rsncode***

An optional output parameter into which the reason code is to be copied from GPR 0.

To code, specify the RS-type address of a fullword field, or register (2)-(12).

## Return codes

The following codes can be returned to the application on this macroinstruction.

**Return code**

**Meaning**

- |          |   |
|----------|---|
| <b>0</b> | Request completed successfully.   |
| <b>4</b> | Request did not complete successfully. See the following reason codes to determine the type of error encountered: |

**Reason code**

**Meaning**

2 Requested function not supported at the present time, service has not been initialized.

## IVTCSM REQUEST=FIX\_BUFFER

### Purpose

Use this macroinstruction to allow an application to change the pageable state of a buffer to be guaranteed to be fixed.

### Usage

If a buffer is guaranteed to be pageable or eligible to be page freed, an application can use this macroinstruction to make the buffer guaranteed to be fixed.

See “Fixed buffers versus pageable buffers” on page 10 for more information.

### Syntax

#### main diagram

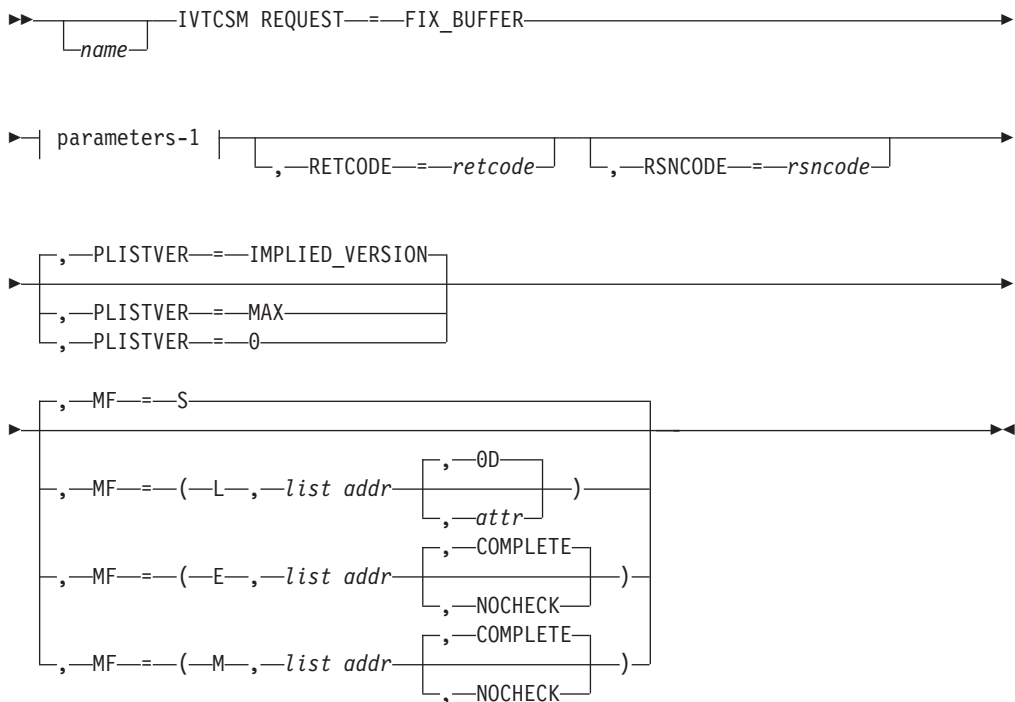

#### parameters-1

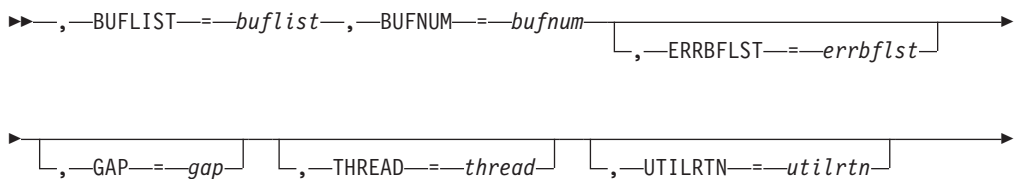





## Parameters

*name*

An optional symbol, starting in column 1, that is the name on the IVTCSM macro invocation. The name must conform to the rules for an ordinary assembler language symbol.

**,BUFLIST=buflist**

A required input parameter of an area in which the application program is to provide a list of buffer entries. The number of entries in the list is equal to the value specified by the BUFNUM parameter. An entry in the list is mapped by IVTBUFL.

The following fields in IVTBUFL are required as input for this request.

- BUFL\_VERSION
- BUFL\_TOKEN

The following field in IVTBUFL is returned as output by CSM for this request.

- BUFL\_TYPE

To code, specify the RS-type address, or address in register (2)-(12), of a field.

**,BUFNUM=bufnum**

A required input parameter, specifying the number of buffers to be made guaranteed to be fixed.

To code, specify the RS-type address, or address in register (2)-(12), of a fullword field.

**,ERRBFLST=errbflst**

An optional output parameter containing the number of the last buffer entry that was successfully processed when an error is detected during processing of the macroinstruction.

To code, specify the RS-type address, or address in register (2)-(12), of a fullword field.

**,GAP=gap**

An optional input parameter, specifying the number of bytes used to separate buffer entries. This parameter allows the buffer entries to be in discontinuous storage. If GAP is not specified, buffer entries are in contiguous storage.

To code, specify the RS-type address, or address in register (2)-(12), of a fullword field.

**,MF=**

An optional input parameter that specifies the macro form.

**MF=S** Specifies the standard form of the macro, which builds an inline parameter list and generates the macro invocation to transfer control to the service. MF=S is the default.

**MF=L** Specifies the list form of the macro. Use the list form together with the execute form of the macro for applications that require reentrant code. The list form defines an area of storage that the execute form uses to store the parameters. Only the PLISTVER parameter can be coded with the list form of the macro.

**MF=E** Specifies the execute form of the macro. Use the execute form together with the list form of the macro for applications that require reentrant code. The execute form of the macro stores the parameters into the storage area defined by the list form, and generates the macro invocation to transfer control to the service.

**MF=M**

Use together with the list and execute forms of the macro for service routines that need to provide different options according to user-provided input. Use the list form to define a storage area; use the modify form to set the appropriate options; then use the execute form to call the service.

**,list addr**

The name of a storage area to contain the parameters. For MF=S, MF=E, and MF=M, this can be an RS-type address or an address in register (1)-(12).

**,attr**

An optional input string 1 - 60 characters in length that you use to force boundary alignment of the parameter list. Use a value of 0F to force the parameter list to a word boundary, or 0D to force the parameter list to a doubleword boundary. If you do not code *attr*, the system provides a value of 0D.

**,COMPLETE**

Specifies that the system is to check for required parameters and supply defaults for omitted optional parameters.

**,NOCHECK**

Specifies that the system is not to check for required parameters and is not to supply defaults for omitted optional parameters.

**Guidelines:** Use the modify and execute forms of IVTCSM in the following order:

1. Use IVTCSM ...MF=(M,list-addr,COMPLETE) specifying appropriate parameters, including all required ones.
2. Use IVTCSM ...MF=(M,list-addr,NOCHECK), specifying the parameters that you want to change.
3. Use IVTCSM ...MF=(E,list-addr,NOCHECK), to execute the macro.

**,PLISTVER=**

An optional input parameter that specifies the version of the macro. PLISTVER determines which parameter list the system generates. PLISTVER is an optional input parameter on all forms of the macro, including the list form. When using PLISTVER, specify it on all macro forms used for a request and with the same value on all of the macro forms. The values are:

**IMPLIED\_VERSION**

The lowest version that allows all parameters specified on the request to be processed. If you omit the PLISTVER parameter, IMPLIED\_VERSION is the default.

**MAX** Specify when you want the parameter list to be the largest size currently possible. This size might increase from release to release and affect the amount of storage that your program needs.

If you can tolerate the size change, you should always specify PLISTVER=MAX on the list form of the macro. Specifying MAX ensures that the list-form parameter list is always long enough to hold

all the parameters you might specify on the execute form; in this way, MAX ensures that the parameter list does not overwrite nearby storage.

0 Specify when you use the currently available parameters.

To code, specify one of the following values:

- IMPLIED\_VERSION
- MAX
- A decimal value of 0

**,RETCODE=retcode**

An optional output parameter into which the return code is to be copied from GPR 15.

To code, specify the RS-type address of a fullword field, or register (2)-(12).

**,RSNCODE=rsncode**

An optional output parameter into which the reason code is to be copied from GPR 0.

To code, specify the RS-type address of a fullword field, or register (2)-(12).

**,THREAD=thread**

An optional input parameter, specifying a unique identifier that is placed in the CSM trace entry to correlate trace records with the application that is requesting the buffers. It is the CSM user's responsibility to ensure that this value is different from the THREAD value specified by other users of the CSM. One way this can be achieved is by specifying an ECSA control block for THREAD.

To code, specify the RS-type address, or address in register (2)-(12), of a 4-character field.

**,UTILRTN=utilrtn**

An optional input parameter that is issued from a utility routine. Specify the utility routine caller's address to be placed in the CSM trace entry. If this parameter is omitted, only the address of the CSM request issuer is placed in the CSM trace entry. This parameter is relevant only to the tracing process. It should be specified only if the CSM user requires identification of the caller of a utility routine in the CSM trace entry.

To code, specify the RS-type address, or address in register (2)-(12), of a fullword field.

**,WAIT=**

An optional parameter, specifying whether or not the request should wait for fixed storage to become available. The default is WAIT=NO.

**,WAIT=NO**

Specifies that this macroinstruction completes without waiting for fixed storage to become available.

**,WAIT=YES**

Specifies that this macroinstruction is not complete until fixed storage becomes available. If fixed storage is not available, users are suspended until enough fixed storage is available to satisfy the request.

## Return codes

The following codes can be returned to the application on this macroinstruction:

**Return code****Meaning**

- 0 Request completed successfully.
- 4 Request did not complete successfully. See the following reason codes to determine the type of error encountered:

**Reason code****Meaning**

- 2 Requested function not supported at the present time, service has not been initialized.
- 7 Specified buffer token is not valid.
- 8 Instance ID in the input buffer token does not match that of the buffer, possible attempt to use a buffer that has been freed.
- 9 Real storage unavailable to provide a fixed buffer, wait not requested.
- 15 Fix buffer request failed because the state of the buffer is guaranteed to be pageable.
- 8 System error while processing the request.

**Reason code****Meaning**

- 6 An abend occurred while processing this request.
- 8 Page fix failed.

**IVTCSM REQUEST=FREE\_BUFFER****Purpose**

Use this macroinstruction to allow an application to return one or more buffers to a storage pool. It is also used to logically return a buffer that has been assigned to multiple owners. The buffer is returned to CSM when the owner of the last buffer image returns it to CSM and a buffer return exit routine was not specified during the initial allocation of the buffer.

**Usage**

An application can specify the address of a buffer return exit routine that is to receive control when the IVTCSM REQUEST=FREE\_BUFFER macroinstruction is issued. See "Buffer return exit routine" on page 18 for more information. An application might optionally specify that the buffer return exit address specified when the buffer was obtained is to be overridden, allowing a buffer to be freed back to CSM that was obtained specifying a free routine address. This option is requested by specifying FREETO=CSM; it must be invoked in this manner only by the requester of the buffer that specified a free routine on the GET\_BUFFER request. If others use this option, the buffer is not returned to the original owner of the buffer.

The application can optionally specify that the buffer obtained is to be cleared when it is returned to the pool on a FREE\_BUFFER request. This allows secure data to be cleared after use.

All IVTCSM REQUEST=GET\_BUFFER|ASSIGN\_BUFFER macroinstructions must have a corresponding FREE\_BUFFER request before the buffer is considered available for reallocation by CSM, or before a buffer return exit routine is invoked for a buffer obtained specifying a buffer return exit routine. This is necessary to ensure that all users have finished using the buffer.

## Syntax

### main diagram

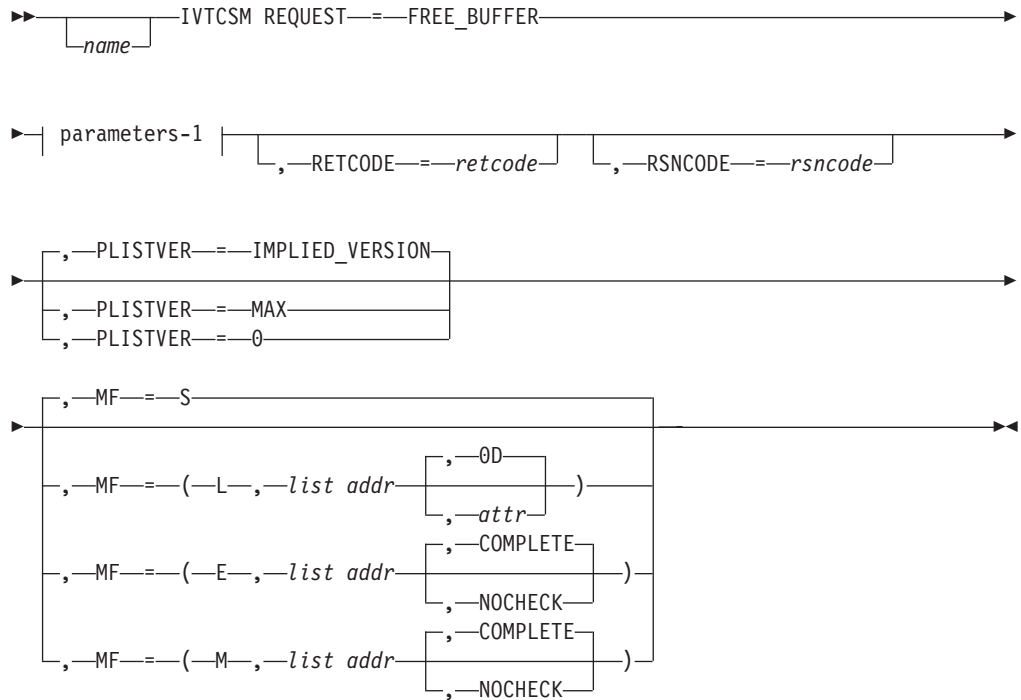

### parameters-1

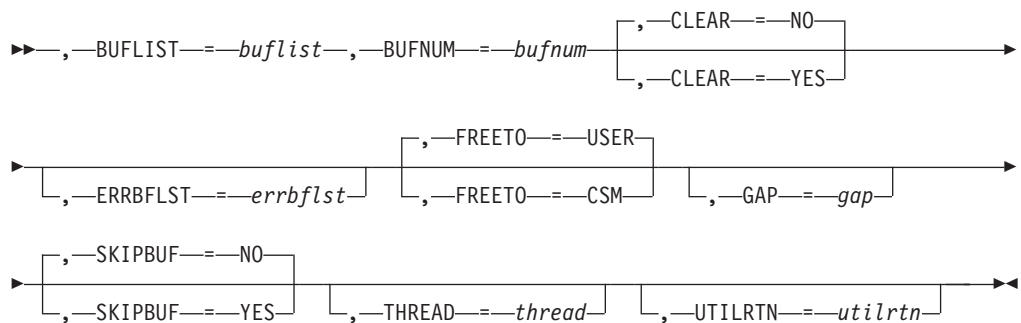

## Parameters

### name

An optional symbol, starting in column 1, that is the name on the IVTCSM macro invocation. The name must conform to the rules for an ordinary assembler language symbol.

**,BUFLIST=buflist**

A required input parameter of an area containing a list of buffer entries. The number of entries in the list is specified by BUFNUM. An entry in the list is mapped by IVTBUFL.

The following fields in IVTBUFL are required as input for this request:

- BUFL\_VERSION
- BUFL\_SOURCE (Required only when SKIPBUF=YES is specified.)
- BUFL\_TOKEN

No fields in IVTBUFL are returned as output by CSM for this request.

To code, specify the RS-type address, or address in register (2)-(12), of a field.

**,BUFNUM=bufnum**

A required input parameter, specifying the number of buffer entries in the list.

To code, specify the RS-type address, or address in register (2)-(12), of a fullword field.

**,CLEAR=**

An optional parameter, specifying whether the buffer is to be cleared when returned to storage pool. The default is CLEAR=NO.

**,CLEAR=NO**

Specifies that the buffer is not cleared when returned to the storage pool. If the buffer was originally allocated with a CLEAR value of YES, then CLEAR=NO is ignored by CSM, and the buffer is cleared when returned to the storage pool.

**,CLEAR=YES**

Specifies that the buffer is to be cleared. Specifying CLEAR=YES does not cause a buffer to be cleared that is returned by a user-specified free routine. However, if CLEAR=YES is specified, the buffer is cleared in the event that it is returned to the storage pool.

**,ERRBFLST=errbflst**

An optional output parameter, specifying the number of the last buffer entry that was successfully processed when an error is detected during processing of the macroinstruction.

To code, specify the RS-type address, or address in register (2)-(12), of a fullword field.

**,FREETO=**

An optional parameter, allowing the FREERTN parameter on the IVTCSM REQUEST=GET\_BUFFER macroinstruction to be overridden. The default is FREETO=USER.

**,FREETO=USER**

Specifies that the buffer is to be returned to the free routine specified on the GET\_BUFFER request.

**,FREETO=CSM**

Specifies that the free routine address provided when the buffer was obtained is to be overridden and the buffer is to be returned to the storage pool. This option should be used only by the original owner of the buffer.

**,GAP=gap**

An optional input parameter, specifying the number of bytes used to separate buffer entries. This parameter allows the buffer entries to be in discontinuous storage. If GAP is not specified, buffer entries are not contiguous.

To code, specify the RS-type address, or address in register (2)-(12), of a fullword field.

**,MF=**

An optional input parameter that specifies the macro form.

**MF=S** Specifies the standard form of the macro, which builds an inline parameter list and generates the macro invocation to transfer control to the service. MF=S is the default.

**MF=L** Specifies the list form of the macro. Use the list form together with the execute form of the macro for applications that require reentrant code. The list form defines an area of storage that the execute form uses to store the parameters. Only the PLISTVER parameter can be coded with the list form of the macro.

Use MF=E to specify the execute form of the macro. Use the execute form together with the list form of the macro for applications that require reentrant code. The execute form of the macro stores the parameters into the storage area defined by the list form, and generates the macro invocation to transfer control to the service.

Use MF=M together with the list and execute forms of the macro for service routines that need to provide different options according to user-provided input. Use the list form to define a storage area; use the modify form to set the appropriate options; then use the execute form to call the service.

**,list addr**

The name of a storage area to contain the parameters. For MF=S, MF=E, and MF=M, this can be an RS-type address or an address in register (1)-(12).

**,attr**

An optional input string 1 - 60 characters in length that you use to force boundary alignment of the parameter list. Use a value of 0F to force the parameter list to a word boundary, or 0D to force the parameter list to a doubleword boundary. If you do not code *attr*, the system provides a value of 0D.

**,COMPLETE**

Specifies that the system is to check for required parameters and supply defaults for omitted optional parameters.

**,NOCHECK**

Specifies that the system is not to check for required parameters and is not to supply defaults for omitted optional parameters.

**Guidelines:** Use the modify and execute forms of IVTCSM in the following order:

1. Use IVTCSM ...MF=(M,list-addr,COMPLETE) specifying appropriate parameters, including all required ones.
2. Use IVTCSM ...MF=(M,list-addr,NOCHECK), specifying the parameters that you want to change.
3. Use IVTCSM ...MF=(E,list-addr,NOCHECK), to execute the macro.

**,PLISTVER=**

An optional input parameter that specifies the version of the macro. PLISTVER determines which parameter list the system generates. PLISTVER is an optional input parameter on all forms of the macro, including the list form.

When using PLISTVER, specify it on all macro forms used for a request and with the same value on all of the macro forms. The values are:

#### **IMPLIED\_VERSION**

The lowest version that allows all parameters specified on the request to be processed. If you omit the PLISTVER parameter, IMPLIED\_VERSION is the default.

**MAX** Code this value if you want the parameter list to be the largest size currently possible. This size might increase from release to release and affect the amount of storage that your program needs.

If you can tolerate the size change, IBM recommends that you always specify PLISTVER=MAX on the list form of the macro. Specifying MAX ensures that the list-form parameter list is always long enough to hold all the parameters you might specify on the execute form; in this way, MAX ensures that the parameter list does not overwrite nearby storage.

**0** Code this value if you use the currently available parameters

To code, specify one of the following values:

- IMPLIED\_VERSION
- MAX
- A decimal value of 0

#### **,RETCODE=*retcode***

An optional output parameter into which the return code is to be copied from GPR 15.

To code, specify the RS-type address of a fullword field, or register (2)-(12).

#### **,RSNCODE=*rsncode***

An optional output parameter into which the reason code is to be copied from GPR 0.

To code, specify the RS-type address of a fullword field, or register (2)-(12).

#### **,SKIPBUF=**

An optional parameter, specifying whether all entries in the buffer list should be processed. The default is SKIPBUF=NO.

##### **,SKIPBUF=NO**

Specifies that all the entries in the buffer list are processed. No entries are skipped. The BUFL\_SOURCE value is not examined.

##### **,SKIPBUF=YES**

Specifies that the only entries in the buffer list that have a BUFL\_SOURCE value indicating the user's non-CSM storage (BUFL\_UDSPACE or BUFL\_USTOR) are skipped.

#### **,THREAD=*thread***

An optional input parameter, specifying a unique identifier that is placed in the CSM trace entry to correlate trace records with the application that is requesting the buffers. It is the CSM user's responsibility to ensure that this value is different from the THREAD value specified by other users of the CSM. One way this can be achieved is by specifying an ECSA control block for THREAD.

To code, specify the RS-type address, or address in register (2)-(12), of a 4-character field.



**,UTILRTN=utilrtn**

An optional input parameter that is issued from a utility routine. Specify the utility routine caller's address to be placed in the CSM trace entry. If this parameter is omitted, only the address of the CSM request issuer is placed in the CSM trace entry. This parameter is relevant only to the tracing process. It should be specified only if the CSM user requires identification of the caller of a utility routine in the CSM trace entry.

To code, specify the RS-type address, or address in register (2)-(12), of a fullword field.

## Return codes

The following codes can be returned to the application on this macroinstruction:

### Return code

#### Meaning

- 0 Request completed successfully.
- 4 Request did not complete successfully. See the following reason codes to determine the type of error encountered.

### Reason code

#### Meaning

- 2 Requested function not supported at the present time, service has not been initialized.
- 7 Pool token specified is not valid.
- 8 Instance ID in the input buffer token does not match that of the buffer, possible attempt to use a buffer that has been freed.
- 8 System error while processing the request.

### Reason code

#### Meaning

- 1 Unable to obtain storage for request.
- 6 An abend occurred while processing this request.

## IVTCSM REQUEST=GET\_BUFFER

### Purpose

Use this macroinstruction allows an application to request one or more buffers of a given size from the CSM storage pool.

### Usage

For the IVTCSM REQUEST=GET\_BUFFER macroinstruction, CSM allocates buffers from a pre-existing pool and returns information to the requester needed to address the buffer. This includes the ALET of a buffer that resides in a data space. The value specified on the POOLTOKN parameter must be the same value returned on the RETPTOKN parameter of the "IVTCSM REQUEST=CREATE\_POOL" on page 40 macroinstruction.

The application has the option of requesting buffers that are guaranteed to be fixed, guaranteed to be pageable, or eligible to be made pageable. A pageable buffer can be obtained and used when fixed buffers are unavailable, and fixed at a

later time using the “IVTCSM REQUEST=FIX\_BUFFER” on page 52 macroinstruction. For data space buffers, the pool token provided on the GET\_BUFFER invocation is used to determine whether the returned buffer is backed by 31-bit or 64-bit real storage. If BACK=64 was specified on the CREATE\_POOL invocation and the machine supports 64-bit backed storage, then a 64-bit backed buffer is returned. If BACK=31 was specified or taken as the default, or BACK=64 was specified but the machine is not executing in z/Architecture mode, then a 31-bit backed buffer is returned.

Ownership of the buffers is assigned to the requesting address space by default. This can be overridden by specifying OWNERID. The OWNERID is the ASID of the address space. Ownership of a buffer can be optionally qualified for a given task by specifying TASKID. The TASKID is a TCB address.

A buffer token is returned with each buffer. The buffer token is the means by which this buffer is known to CSM. This token must be used with all other requests to CSM for the associated buffer.

The application can also specify a free routine address that is to receive control when the IVTCSM REQUEST=FREE\_BUFFER macroinstruction is issued for the buffer. The default is that the buffers are to be returned to CSM.

The application can also specify that the buffer obtained is to be cleared when it is returned to the pool. This provides for secure data to be cleared after processing is complete.

## Syntax

### main diagram

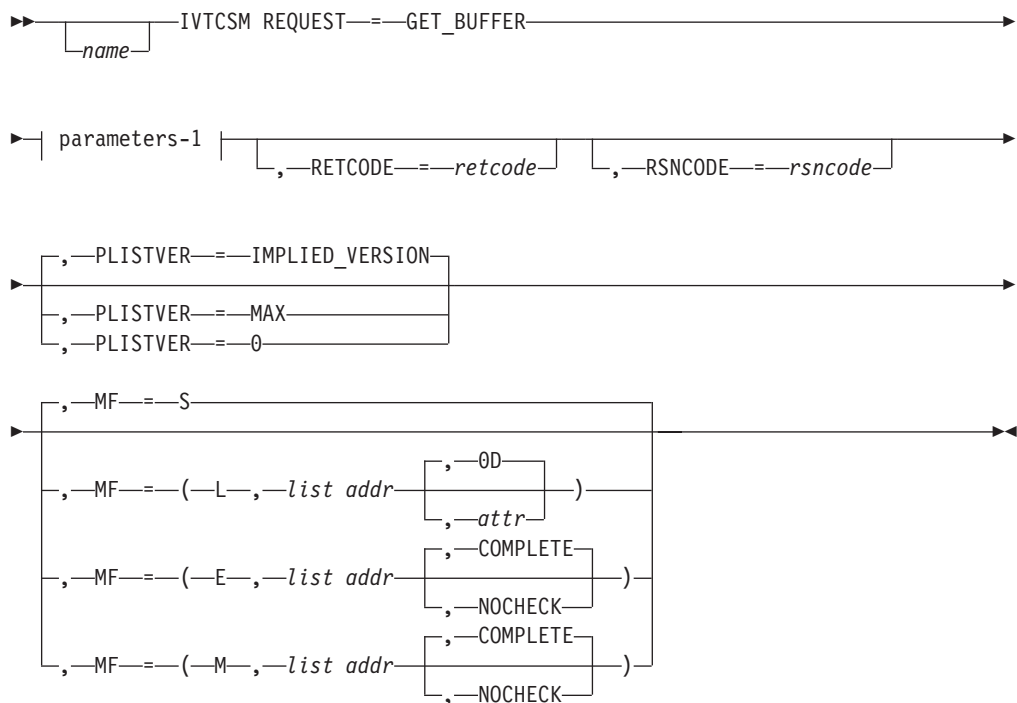

## parameters-1

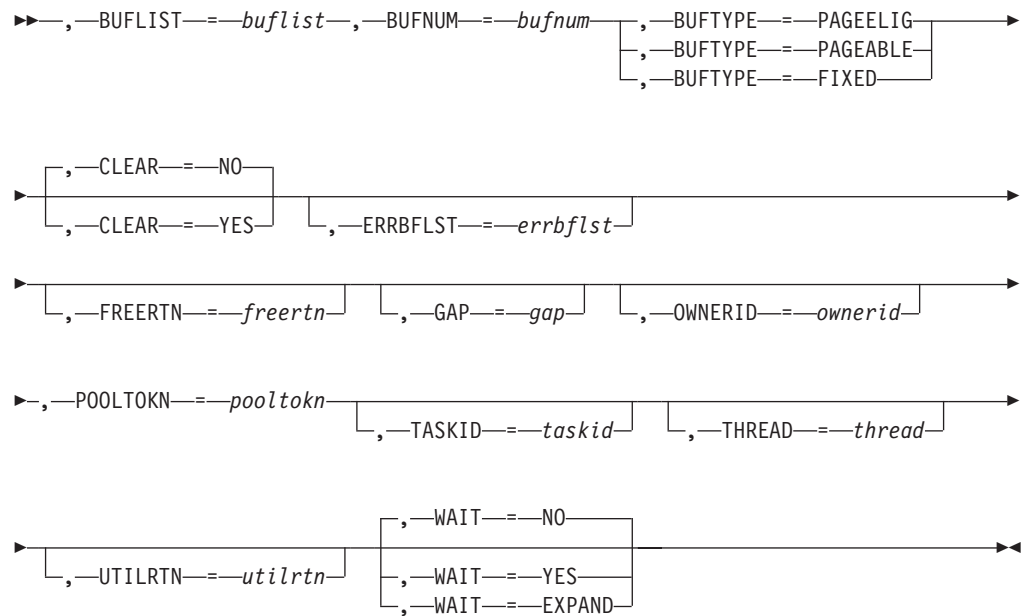

## Parameters

### *name*

An optional symbol, starting in column 1, that is the name on the IVTCSM macro invocation. The name must conform to the rules for an ordinary assembler language symbol.

### **,BUFLIST=*buflist***

A required input parameter of an area containing a list of buffer entries. The number of entries in the list is equal to the value specified by the BUFNUM parameter. An entry in the list is mapped by IVTBUFL.

The following field in IVTBUFL is required as input for this request.

- BUFL\_VERSION

The following fields in IVTBUFL are returned as output by CSM for this request.

- BUFL\_SOURCE
- BUFL\_TYPE
- BUFL\_TOKEN
- BUFL\_ALET (Returned only if the buffer was allocated from a data space.)
- BUFL\_ADDR
- BUFL\_SIZE

To code, specify the RS-type address, or address in register (2)-(12), of a field.

### **,BUFNUM=*bufnum***

A required input parameter, specifying the number of buffers to be obtained.

To code, specify the RS-type address, or address in register (2)-(12), of a fullword field.

### **,BUFTYPE=**

A required parameter, specifying whether the buffers are to be guaranteed to be fixed, guaranteed to be pageable or eligible to be made pageable.

**,BUFTYPE=PAGEELIG**

Indicates that the buffers are eligible to be made pageable.

**,BUFTYPE=PAGEABLE**

Indicates that the buffers are to be guaranteed to be pageable.

**,BUFTYPE=FIXED**

Indicates that buffers are to be guaranteed to be fixed.

**,CLEAR=**

An optional parameter, specifying whether the buffer is to be cleared when returned to the storage pool. The default is CLEAR=NO.

**,CLEAR=NO**

Specifies that the buffer is not cleared when returned to the buffer pool

**,CLEAR=YES**

Specifies that the buffer is cleared. Specifying CLEAR=YES does not cause a buffer to be cleared that is returned via a user-specified free routine. However, if CLEAR=YES is specified, the buffer is cleared in the event that it is returned to the storage pool.

**,ERRBFLST=*errbflst***

An optional output parameter containing the number of the last buffer entry that was successfully processed when an error is detected during processing of the macroinstruction.

To code, specify the RS-type address, or address in register (2)-(12), of a fullword field.

**,FREERTN=*freertn***

An optional input parameter that is to contain the address of an application routine that is to receive control when the buffer is freed. This allows the buffer to be passed to another application or product such as VTAM and to receive the buffer back when the receiver is finished. The free routine is scheduled for execution in the address space of the original owner of the buffer. See "Buffer return exit routine" on page 18 for more information.

To code, specify the RS-type address, or address in register (2)-(12), of a pointer field.

**,GAP=*gap***

An optional input parameter, specifying the number of bytes used to separate buffer entries. This parameter allows the buffer entries to be in discontinuous storage. If GAP is not specified, buffer entries are contiguous.

To code, specify the RS-type address, or address in register (2)-(12), of a fullword field.

**,MF=**

An optional input parameter that specifies the macro form.

**MF=S** Specifies the standard form of the macro, which builds an inline parameter list and generates the macro invocation to transfer control to the service. MF=S is the default.

**MF=L** Specifies the list form of the macro. Use the list form together with the execute form of the macro for applications that require reentrant code. The list form defines an area of storage that the execute form uses to store the parameters. Only the PLISTVER parameter be coded with the list form of the macro.

**MF=E** Specifies to specify the execute form of the macro. Use the execute

form together with the list form of the macro for applications that require reentrant code. The execute form of the macro stores the parameters into the storage area defined by the list form, and generates the macro invocation to transfer control to the service.

#### **MF=M**

Use together with the list and execute forms of the macro for service routines that need to provide different options according to user-provided input. Use the list form to define a storage area; use the modify form to set the appropriate options; then use the execute form to call the service.

#### **,list addr**

The name of a storage area to contain the parameters. For MF=S, MF=E, and MF=M, this can be an RS-type address or an address in register (1)-(12).

#### **,attr**

An optional input string 1 - 60 characters in length that you use to force boundary alignment of the parameter list. Use a value of 0F to force the parameter list to a word boundary, or 0D to force the parameter list to a doubleword boundary. If you do not code *attr*, the system provides a value of 0D.

#### **,COMPLETE**

Specifies that the system is to check for required parameters and supply defaults for omitted optional parameters.

#### **,NOCHECK**

Specifies that the system is not to check for required parameters and is not to supply defaults for omitted optional parameters.

**Note:** Use the modify and execute forms of IVTCSM in the following order:

1. Use IVTCSM ...MF=(M,list-addr,COMPLETE) specifying appropriate parameters, including all required ones.
2. Use IVTCSM ...MF=(M,list-addr,NOCHECK), specifying the parameters that you want to change.
3. Use IVTCSM ...MF=(E,list-addr,NOCHECK), to execute the macro.

#### **,OWNERID=ownerid**

An optional input parameter, specifying the owner of the buffer being obtained.

To code, specify the RS-type address, or address in register (2)-(12), of a halfword field.

#### **,PLISTVER=**

An optional input parameter that specifies the version of the macro. PLISTVER determines which parameter list the system generates. PLISTVER is an optional input parameter on all forms of the macro, including the list form. When using PLISTVER, specify it on all macro forms used for a request and with the same value on all of the macro forms. The values are:

#### **IMPLIED\_VERSION**

The lowest version that allows all parameters specified on the request to be processed. If you omit the PLISTVER parameter, IMPLIED\_VERSION is the default.

**MAX** Specify when you want the parameter list to be the largest size

currently possible. This size might increase from release to release and affect the amount of storage that your program needs.

If you can tolerate the size change, you should always specify `PLISTVER=MAX` on the list form of the macro. Specifying `MAX` ensures that the list-form parameter list is always long enough to hold all the parameters you might specify on the execute form; in this way, `MAX` ensures that the parameter list does not overwrite nearby storage.

**0** Specify when you use the currently available parameters.

To code, specify one of the following values:

- `IMPLIED_VERSION`
- `MAX`
- A decimal value of 0

**,POOLTKN=pooltokn**

A required input parameter of the token representing this user of this pool. This must be the token provided to the application on the associated `IVTCSM REQUEST=CREATE_POOL` macroinstruction.

To code, specify the RS-type address, or address in register (2)-(12), of a 10-character field.

**,RETCODE=retcode**

An optional output parameter into which the return code is to be copied from GPR 15.

To code, specify the RS-type address of a fullword field, or register (2)-(12).

**,RSNCODE=rsncode**

An optional output parameter into which the reason code is to be copied from GPR 0.

To code, specify the RS-type address of a fullword field, or register (2)-(12).

**,TASKID=taskid**

An optional input parameter that is to contain the address of a TCB. This further qualifies the ownership of a buffer to a specific task. If `TASKID` is not specified, the buffer is not associated with a task but is instead associated with the issuing application's ASID.

To code, specify the RS-type address, or address in register (2)-(12), of a pointer field.

**,THREAD=thread**

An optional input parameter, specifying a unique identifier that is placed in the CSM trace entry to correlate trace records with the application that is requesting the buffers. It is the CSM user's responsibility to ensure that this value is different from the `THREAD` value specified by other users of the CSM. One way this can be achieved is by specifying an ECSA control block for `THREAD`.

To code, specify the RS-type address, or address in register (2)-(12), of a 4-character field.

**,UTILRTN=utilrtn**

An optional input parameter that is issued from a utility routine. Specify the utility routine caller's address to be placed in the CSM trace entry. If this parameter is omitted, only the address of the CSM request issuer is placed in

the CSM trace entry. This parameter is relevant only to the tracing process. It should be specified only if the CSM user requires identification of the caller of a utility routine in the CSM trace entry.

To code, specify the RS-type address, or address in register (2)-(12), of a fullword field.

**,WAIT=**

An optional parameter, specifying whether or not the request should wait for buffers to become available. The default is WAIT=NO.

**,WAIT=NO**

Specifies that this macroinstruction completes without waiting for an available buffer.

**,WAIT=YES**

Specifies that this macroinstruction does not complete until all buffers become available. If buffers are not available, users are suspended until enough buffers become available to satisfy the request.

**,WAIT=EXPAND**

Specifies that this macroinstruction waits for pool expansion to complete. If enough buffers are not available to satisfy the request, users are suspended until expansion completes.

## Return codes

The following codes can be returned to the application on this macroinstruction:

**Return code**

**Meaning**

- 0 Request completed successfully.
- 4 Request did not complete successfully. See the following reason codes to determine the type of error encountered.

**Reason code**

**Meaning**

- 2 Requested function not supported at the present time, service has not been initialized.
- 4 Buffer pool cannot be expanded to satisfy request.
- 5 No available buffers in pool, wait not requested.
- 6 Pool token specified is not valid.
- 9 Real storage unavailable to provide a fixed buffer, wait not requested.
- 11 A problem has been detected with the pool associated with the CSM request. The user should free all buffers when finished using them and issue a delete pool request to terminate usage of this pool. To allocate new buffers, a new pool must be created by issuing a new create pool request.
- 16 Instance ID in the input pooltoken does not match that of the user, possible attempt to allocate buffers after issuing a DELETE\_POOL request.
- 17 Extent has been overlaid. Reissue the request.
- 20 BUFTYPE value specified is not valid for this request.

- 24 ASID specified on the OWNERID parameter is not active.
- 25 CSM is waiting for the buffers.
- 8 System error while processing the request. See the following reason codes to determine the type of error encountered.

**Reason code**

**Meaning**

- 1 Unable to obtain storage for request.
- 3 Unable to create ALET for data space.
- 4 Error encountered, while creating the data space.
- 5 Unable to create another data space. Number of data spaces exceeds the maximum.
- 6 An abend occurred while processing this request.

## IVTCSM REQUEST=PAGE\_BUFFER

### Purpose

Use this macroinstruction to allow an application to change the pageable state of a buffer.

### Usage

An application can use this macroinstruction to make the buffer guaranteed to be pageable or eligible to be paged.

When BUFTYPE=PAGEELIG is specified on this macroinstruction, the buffer is marked as eligible to be paged. The buffer is not physically unfixed unless CSM requires real storage to satisfy another CSM request. This avoids the potential overhead of unnecessary fixing and freeing of storage.

This macroinstruction can be used to avoid consuming real storage for data that is being held in a buffer for possible use at a later time.

When BUFTYPE=PAGEABLE is specified on this macroinstruction, the buffer is marked as guaranteed to be pageable. This macroinstruction be used when a system service requires pageable storage on input. This macroinstruction can be issued for a buffer consisting of only one image. This restriction guarantees that a user of a buffer that has multiple images can successfully issue a FIX\_BUFFER request if necessary. Fixing a buffer requires that the entire buffer be fixed, even if the user is interested in only a piece of the buffer.

### Syntax

#### main diagram

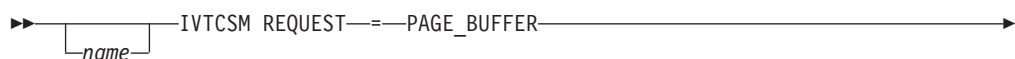



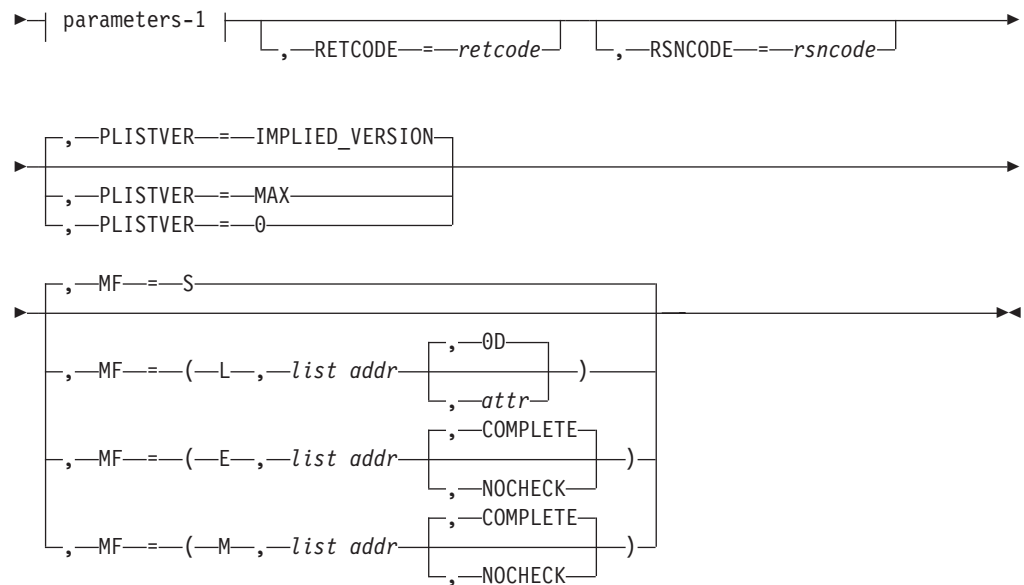

### parameters-1

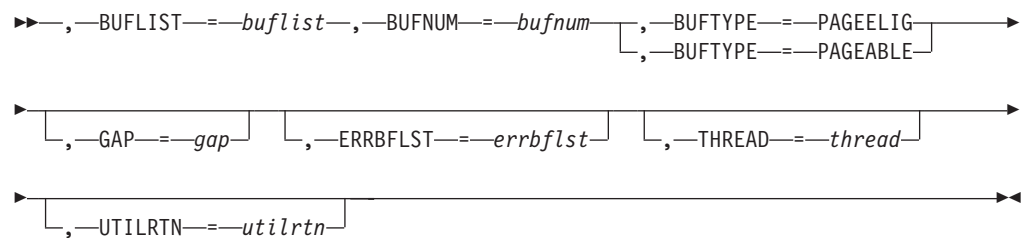

## Parameters

### *name*

An optional symbol, starting in column 1, that is the name on the IVTCSM macro invocation. The name must conform to the rules for an ordinary assembler language symbol.

### **,BUFLIST=buflist**

A required input parameter of an area containing a list of buffer entries. The number of entries in the list is specified by BUFNUM. An entry in the buffer list is mapped by IVTBUFL.

The following fields in IVTBUFL are required as input for this request:

- BUFL\_VERSION
- BUFL\_TOKEN

The following field in IVTBUFL is returned as output by CSM for this request:

- BUFL\_TYPE

To code, specify the RS-type address, or address in register (2)-(12), of a field.

### **,BUFNUM=bufnum**

A required input parameter, specifying the number of buffers to be made pageable or eligible to be paged.

To code, specify the RS-type address, or address in register (2)-(12), of a fullword field.

**,BUFTYPE=**

A required parameter, specifying whether the buffers are to be guaranteed to be pageable or eligible to be made pageable.

**,BUFTYPE=PAGEELIG**

Indicates that the buffers are eligible to be made pageable.

**,BUFTYPE=PAGEABLE**

Indicates that the buffers are to be guaranteed to be pageable.

**,ERRBFLST=errbflst**

An optional output parameter containing the number of the last buffer entry that was successfully processed when an error is detected during processing of the macroinstruction.

To code, specify the RS-type address, or address in register (2)-(12), of a fullword field.

**,GAP=gap**

An optional input parameter, specifying the number of bytes used to separate buffer entries. This parameter allows the buffer entries to be in discontinuous storage. If GAP is not specified, buffer entries are contiguous.

To code, specify the RS-type address, or address in register (2)-(12), of a fullword field.

**,MF=**

An optional input parameter that specifies the macro form.

**MF=S** Specifies the standard form of the macro, which builds an inline parameter list and generates the macro invocation to transfer control to the service. MF=S is the default

**MF=L** Specifies the list form of the macro. Use the list form together with the execute form of the macro for applications that require reentrant code. The list form defines an area of storage that the execute form uses to store the parameters. Only the PLISTVER parameter be coded with the list form of the macro.

**MF=E** Specifies the execute form of the macro. Use the execute form together with the list form of the macro for applications that require reentrant code. The execute form of the macro stores the parameters into the storage area defined by the list form, and generates the macro invocation to transfer control to the service.

**MF=M**

Use this value together with the list and execute forms of the macro for service routines that need to provide different options according to user-provided input. Use the list form to define a storage area; use the modify form to set the appropriate options; then use the execute form to call the service.

**,list addr**

The name of a storage area to contain the parameters. For MF=S, MF=E, and MF=M, this can be an RS-type address or an address in register (1)-(12).

**,attr**

An optional input string 1 - 60 characters in length that you use to force boundary alignment of the parameter list. Use a value of 0F to force the

parameter list to a word boundary, or 0D to force the parameter list to a doubleword boundary. If you do not code *attr*, the system provides a value of 0D.

**,COMPLETE**

Specifies that the system is to check for required parameters and supply defaults for omitted optional parameters.

**,NOCHECK**

Specifies that the system is not to check for required parameters and is not to supply defaults for omitted optional parameters.

**Note:** Use the modify and execute forms of IVTCSM in the following order:

1. Use IVTCSM ...MF=(M,list-addr,COMPLETE) specifying appropriate parameters, including all required ones.
2. Use IVTCSM ...MF=(M,list-addr,NOCHECK), specifying the parameters that you want to change.
3. Use IVTCSM ...MF=(E,list-addr,NOCHECK), to execute the macro.

**,PLISTVER=**

An optional input parameter that specifies the version of the macro. PLISTVER determines which parameter list the system generates. PLISTVER is an optional input parameter on all forms of the macro, including the list form. When using PLISTVER, specify it on all macro forms used for a request and with the same value on all of the macro forms. The values are:

**IMPLIED\_VERSION**

The lowest version that allows all parameters specified on the request to be processed. If you omit the PLISTVER parameter, IMPLIED\_VERSION is the default.

**MAX** Code this value if you want the parameter list to be the largest size currently possible. This size might increase from release to release and affect the amount of storage that your program needs.

If you can tolerate the size change, always specify PLISTVER=MAX on the list form of the macro. Specifying MAX ensures that the list-form parameter list is always long enough to hold all the parameters you might specify on the execute form; in this way, MAX ensures that the parameter list does not overwrite nearby storage.

**0** Code this value if you use the currently available parameters.

To code, specify one of the following values:

- IMPLIED\_VERSION
- MAX
- A decimal value of 0

**,RETCODE=*retcode***

An optional output parameter into which the return code is to be copied from GPR 15.

To code, specify the RS-type address of a fullword field, or register (2)-(12).

**,RSNCODE=*rsncode***

An optional output parameter into which the reason code is to be copied from GPR 0.

To code, specify the RS-type address of a fullword field, or register (2)-(12).

**,THREAD=thread**

An optional input parameter, specifying a unique identifier that is placed in the CSM trace entry to correlate trace records with the application that is requesting the buffers. It is the CSM user's responsibility to ensure that this value is different from the THREAD value specified by other users of the CSM. One way this can be achieved is by specifying an ECSA control block for THREAD.

To code, specify the RS-type address, or address in register (2)-(12), of a 4-character field.

**,UTILRTN=utilrtn**

An optional input parameter that is issued from a utility routine. Specify the utility routine caller's address to be placed in the CSM trace entry. If this parameter is omitted, only the address of the CSM request issuer is placed in the CSM trace entry. This parameter is relevant only to the tracing process. It should be specified only if the CSM user requires identification of the caller of a utility routine in the CSM trace entry.

To code, specify the RS-type address, or address in register (2)-(12), of a fullword field.

## Return codes

The following codes can be returned to the application on this macroinstruction:

### Return code

#### Meaning

- 0 Request completed successfully.
- 4 Request did not complete successfully. See the following reason codes to determine the type of error encountered.

### Reason code

#### Meaning

- 2 Requested function not supported at the present time, service has not been initialized.
- 7 Pool token specified is not valid.
- 8 Instance ID in the input pool token does not match that of the buffer, possible attempt to use a buffer that has been freed.
- 10 Request to make a buffer pageable denied, more than one image of the buffer exists.
- 20 BUFTYPE value specified is not valid for this request.
- 8 System error while processing the request

### Reason code

#### Meaning

- 1 Unable to obtain storage for request.
- 6 An abend occurred while processing this request.

# IVTCSM REQUEST=RESOURCE\_STATS

## Purpose

Use this macroinstruction to request that the address of the information required to monitor the usage of ECSA, data space, and fixed storage be returned.

## Usage

When this macroinstruction is issued, CSM returns the address of a 4-byte area containing the status of ECSA, data space, and fixed storage resources. Applications can issue this macroinstruction during initialization processing and use the address throughout normal processing. The status information contained in this area indicates whether the use of a resource is normal, constrained, or critical. If a resource usage is determined to be constrained or critical, users of CSM can take action to prevent critical shortages that might jeopardize the application's or system's operation, including:

- Selecting a different storage source for buffer pools
- Limiting usage of fixed storage

## Syntax

### main diagram

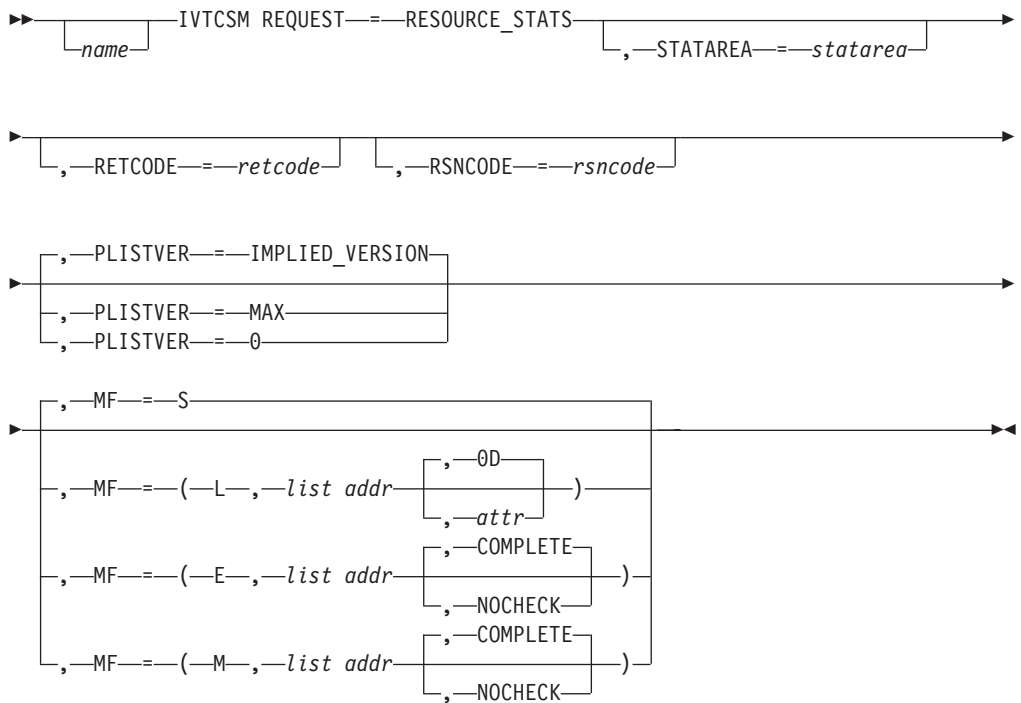

## Parameters

### name

An optional symbol, starting in column 1, that is the name on the IVTCSM macro invocation. The name must conform to the rules for an ordinary assembler language symbol.

### ,MF=

An optional input parameter that specifies the macro form.

**MF=S** Specifies the standard form of the macro, which builds an inline parameter list and generates the macro invocation to transfer control to the service. MF=S is the default.

**MF=L** Specifies the list form of the macro. Use the list form together with the execute form of the macro for applications that require reentrant code. The list form defines an area of storage that the execute form uses to store the parameters. Only the PLISTVER parameter be coded with the list form of the macro.

**MF=E** Specifies the execute form of the macro. Use the execute form together with the list form of the macro for applications that require reentrant code. The execute form of the macro stores the parameters into the storage area defined by the list form, and generates the macro invocation to transfer control to the service.

**MF=M**

Code this value together with the list and execute forms of the macro for service routines that need to provide different options according to user-provided input. Use the list form to define a storage area; use the modify form to set the appropriate options; then use the execute form to call the service.

**,list addr**

The name of a storage area to contain the parameters. For MF=S, MF=E, and MF=M, this can be an RS-type address or an address in register (1)-(12).

**,attr**

An optional input string 1 - 60 characters in length that you use to force boundary alignment of the parameter list. Use a value of 0F to force the parameter list to a word boundary, or 0D to force the parameter list to a doubleword boundary. If you do not code *attr*, the system provides a value of 0D.

**,COMPLETE**

Specifies that the system is to check for required parameters and supply defaults for omitted optional parameters.

**,NOCHECK**

Specifies that the system is not to check for required parameters and is not to supply defaults for omitted optional parameters.

**Note:** Use the modify and execute forms of IVTCSM in the following order:

1. Use IVTCSM ...MF=(M,list-addr,COMPLETE) specifying appropriate parameters, including all required ones.
2. Use IVTCSM ...MF=(M,list-addr,NOCHECK), specifying the parameters that you want to change.
3. Use IVTCSM ...MF=(E,list-addr,NOCHECK), to execute the macro.

**,PLISTVER=**

An optional input parameter that specifies the version of the macro. PLISTVER determines which parameter list the system generates. PLISTVER is an optional input parameter on all forms of the macro, including the list form. When using PLISTVER, specify it on all macro forms used for a request and with the same value on all of the macro forms. The values are:

## IMPLIED\_VERSION

The lowest version that allows all parameters specified on the request to be processed. If you omit the PLISTVER parameter, IMPLIED\_VERSION is the default.

**MAX** Code this value if you want the parameter list to be the largest size currently possible. This size might increase from release to release and affect the amount of storage that your program needs.

If you can tolerate the size change, you should always specify PLISTVER=MAX on the list form of the macro. Specifying MAX ensures that the list-form parameter list is always long enough to hold all the parameters you might specify on the execute form; in this way, MAX ensures that the parameter list does not overwrite nearby storage.

**0** Code this value if you use the currently available parameters.

To code, specify one of the following values:

- IMPLIED\_VERSION
- MAX
- A decimal value of 0

### **,RETCODE=retcode**

An optional output parameter into which the return code is to be copied from GPR 15.

To code, specify the RS-type address of a fullword field, or register (2)-(12).

### **,RSNCODE=rsncode**

An optional output parameter into which the reason code is to be copied from GPR 0.

To code, specify the RS-type address of a fullword field, or register (2)-(12).

### **,STATAREA=statarea**

An optional output parameter that contains the address of an area containing the resource statistics mapped by IVTSTATA.

The information returned is in a non-fetch protected area and can be accessed while executing in any storage key.

To code, specify the RS-type address, or address in register (2)-(12), of a pointer field.

## Return codes

The following codes can be returned to the application on this macroinstruction:

### Return code

#### Meaning

- |   |   |
|---|---|
| 0 | Request completed successfully.   |
| 4 | Request did not complete successfully. See the following reason codes to determine the type of error encountered. |

#### Reason code

#### Meaning

- |   |   |
|---|---|
| 2 | Requested function not supported at the present time, service has not been initialized. |
|---|---|





---

## Appendix A. IVTCSM macroinstruction return and reason codes

This appendix describes return and reason codes that can be returned to an application issuing the IVTCSM macroinstruction. These codes are listed in Table 6.

**Guideline:** For all macroinstructions that invoke CSM, the application can examine return codes in register 15 and reason codes in register 0.

*Table 6. IVTCSM macroinstruction return and reason codes*

Return code	Meaning
0	Request completed successfully.

Table 6. IVTCSM macroinstruction return and reason codes (continued)

Return code	Meaning
4	Request did not complete successfully. See the following reason codes and meanings to identify the type of error encountered:
1	Requested function not supported.
2	Requested function not supported at the present time, service has not been initialized.
3	Specified buffer size is larger than supported size.
4	Buffer pool cannot be expanded to satisfy request.
5	No available buffers in pool, wait not requested.
6	Pool token specified is not valid.
7	Buffer token specified is not valid.
8	Instance ID in the input buffer token does not match that of the buffer, possible attempt to use a buffer that has been freed.
9	Real storage unavailable to provide a fixed buffer, wait not requested.
10	Request to make a buffer pageable denied, more than one image of the buffer exists.
11	A problem has been detected with the pool associated with the CSM request. The user should free all buffers when finished using them and issue a delete pool request to terminate usage of this pool. To allocate new buffers, issue a new create pool request to create a new pool.
12	Address and length specified on a copy data request for a source buffer descriptor is outside the bounds of the CSM buffer represented by the specified pool token.
13	Address and length specified on a copy data request for a target buffer descriptor is outside the bounds of the CSM buffer represented by the specified pool token.
14	Copy operation resulted in truncation of source data due to insufficient buffer space provided by the target buffer list.
15	Assign buffer request failed because the state of the buffer is guaranteed to be pageable.
16	Instance ID in the input pool token does not match that of the user, possible attempt to allocate buffers after issuing a DELETE_POOL request.
17	Extent has been overlaid. Reissue the request.
18	BUFL_SOURCE value is not valid for an entry in the Source buffer list (SRCLIST).
19	BUFL_SOURCE value is not valid for an entry in the Target buffer list (TRGLIST).
20	BUFTYPE value specified is not valid for this request
21	BUFSOURC value is not valid for this request.
22	Source and target buffers overlap, no data has been copied.
23	Unable to create the specified pool. Creation of the pool would cause the ECSA maximum limit to be exceeded.
24	ASID specified on the OWNERID parameter is not active.
25	CSM is waiting for the buffer.
26	Assign buffer request failed because CSM reached the maximum number of image buffers of the single CSM buffer.

Table 6. IVTCSM macroinstruction return and reason codes (continued)

Return code	Meaning
8	<p>System error while processing the request. See the following reason codes and meaning codes to identify the type of error encountered:</p> <ul style="list-style-type: none"> <li data-bbox="347 331 1458 367">1      Unable to obtain storage for request.</li> <li data-bbox="347 373 1458 409">2      Schedule SRB fail for PC routine.</li> <li data-bbox="347 415 1458 451">3      Unable to create ALET for data space.</li> <li data-bbox="347 457 1458 493">4      Error encountered while creating the data space.</li> <li data-bbox="347 499 1458 535">5      Unable to create another data space. Number of data spaces exceeds the maximum.</li> <li data-bbox="347 541 1458 577">6      An abend occurred while processing this request.</li> <li data-bbox="347 583 1458 619">8      Page fix failed.</li> </ul>



## Appendix B. CSM DSECTS

This appendix contains the CSM DSECTS and contains the following sections:

- “CSM buffer list entry (IVTBUFL)”
- “CSM data space information (IVTDATSP)” on page 83
- “CSM resource status area (IVTSTATA)” on page 83

For general information on the use and purpose of DSECTS, see the z/OS Communications Server: SNA Programming.

Use the following information to interpret this appendix:

- DSECTS are shown as an abbreviated form of an assembler listing.
- The first column indicates the offsets within the DSECT and is the LOC column of an assembler listing. However, the object code, address columns, and statement number columns of the listing are not included.
- The source statements and comments are next to the offset column.
- All numbers in the offset column are in hexadecimal.

### CSM buffer list entry (IVTBUFL)

The DSECT IVTBUFL maps an entry in the CSM buffer list that can be indicated by the BUFLIST, SRCLIST or TARGLIST parameters on the IVTCSM macroinstruction.

**Requirements:** The buffer list pointed to by the BUFLIST parameter is required on the following IVTCSM requests:

- “IVTCSM REQUEST=ASSIGN\_BUFFER” on page 23
- “IVTCSM REQUEST=CHANGE\_OWNER” on page 29
- “IVTCSM REQUEST=FIX\_BUFFER” on page 52
- “IVTCSM REQUEST=FREE\_BUFFER” on page 56
- “IVTCSM REQUEST=GET\_BUFFER” on page 61
- “IVTCSM REQUEST=PAGE\_BUFFER” on page 68
- The buffer list pointed to by SRCLIST and TARGLIST is required on the “IVTCSM REQUEST=COPY\_DATA” on page 34 macroinstruction.

Table 7. CSM buffer list format

CSM buffer list format							
V E R S I O N	S O U R C E	T Y P E	0	BUFFER TOKEN	CSM DATA SPACE ALET	BUFFER ADDRESS	BUFFER LENGTH

Byte (hex)  
Contents

00 Version  
 01 Indicates the buffer source  
     X'80' ECSA  
     X'40' Data space  
     X'20' User data space  
     X'10' User storage area other than a data space

02 Indicates the state of the buffers  
     X'80' Fixed  
     X'40' Pageable  
     X'20' Eligible to be page freed

03 0

04 - 0F Buffer token

10 - 13 ALET for the data space

14 - 17 Address of buffer

18 - 1B Length of buffer

LOC	SOURCE STATEMENT			BUFFER DESCRIPTOR
000000	IVTBUFL DSECT			VERSION OF BUFFER DESCRIPTOR
000000	BUFL_VERSION DS X			VERSION 0
	BUFL_VERSIONC EQU X'00'			VERSION 0
000001	BUFL_SOURCE DS X			BUFFER SOURCE
	BUFL_CECSA EQU X'80'			INDICATES THAT THE STORAGE IS IN CSM ECSA
	* BUFL_CDSPACE EQU X'40'			INDICATES THAT THE STORAGE IS IN CSM DATA SPACE
	* BUFL_UDSPACE EQU X'20'			INDICATES THAT THE STORAGE IS IN A USER DATA SPACE
	* BUFL_USTOR EQU X'10'			INDICATES THAT THE STORAGE IS A USER'S STORAGE OTHER THAN A DATA SPACE
	* BUFL_TYPE DS X			BUFFER TYPE
000002	BUFL_FIXED EQU X'80'			INDICATES THAT THE STORAGE IS IN A GUARANTEED TO BE FIXED STATE
	* BUFL_PAGEABLE EQU X'40'			INDICATES THAT THE STORAGE IS IN A GUARANTEED TO BE PAGEABLE STATE
	* BUFL_PAGEELIG EQU X'20'			INDICATES THAT THE STORAGE IS ELIGIBLE TO BE PAGEFREED BY CSM
	* DS XL1			RESERVED
000004	BUFL_TOKEN DS XL12			CSM BUFFER TOKEN
000010	BUFL_ALET DS F			DATA SPACE ALET
000014	BUFL_ADDR DS A			POINTER TO BUFFER
000018	BUFL_SIZE DS F			THE SIZE OF THE ALLOCATED BUFFER ON GET_BUFFER REQUESTS, THE DATA LENGTH ON COPY_DATA REQUESTS
	* BUFL_END DS 0F			END OF IVTBUFL

## CSM data space information (IVTDATSP)

IVTDATSP maps the information required to include CSM data space buffers in a user dump. The address of this information can be optionally returned to the user on the “IVTCSM REQUEST=CREATE\_POOL” on page 40 and “IVTCSM REQUEST=DUMP\_INFO” on page 49 macroinstructions.

Table 8. IVTDATSP DSECT layout

IVTDATSP DSECT layout			
DATS	NUMBER OF DATA SPACES	LENGTH OF DATA SPACE ENTRIES	DATA SPACE ENTRIES MAPPED BY DATSP_ENT

Byte (hex)	Field name	Contents
00—03	DATSP_ACRO	DATS
04—07	DATSP_SNUM	Number of data spaces
08—0B	DATSP_SLEN	Length of a data space information entry
0C—	DATSP_SINF	All of the data space entries. The number of entries is determined by DATSP_SNUM. Each entry is separately mapped by the DATSP_ENT DSECT and includes the following information:

### Byte (hex)

#### Contents

00—07	STOKEN for the data space
08—0F	Data space name
10—	ALET for the data space

LOC	SOURCE STATEMENT	
000000	IVTDATSP DSECT	CSM DATA SPACE INFORMATION
000000	DATSP_ACRO DS CL4	Eyecatcher 'DATS'
000004	DATSP_SNUM DS F	NUMBER OF DATA SPACES
000008	DATSP_SLEN DS F	LENGTH OF A DATA SPACE INFORMATION ENTRY
	*	
00000C	DATSP_SINF DS 5XL20	CONTAINS ALL THE DATA SPACE INFORMATION ENTRIES. THESE ENTRIES ARE MAPPED BY THE DATSP_ENT DSECT.
	*	THERE WILL BE ONE ENTRY FOR EACH DATA SPACE INDICATED BY DATSP_SNUM, AND EACH ENTRY MUST BE SEPARATELY MAPPED BY THE DATSP_ENT DSECT.
	*	
	*	
	*	
	*	
	*	
	*	
000000	DATSP_ENT DSECT	DATA SPACE INFORMATION ENTRY
000000	DATSP_TOKN DS XL8	STOKEN FOR THE DATA SPACE
000008	DATSP_NAME DS XL8	DATA SPACE NAME
000010	DATSP_ALET DS F	ALET FOR THE DATA SPACE

## CSM resource status area (IVTSTATA)

IVTSTATA maps the information required to monitor the usage of CSM resources such as ECSA, data space and fixed storage. The address of the information can be optionally returned to the user on the “IVTCSM REQUEST=CREATE\_POOL” on page 40 and “IVTCSM REQUEST=RESOURCE\_STATS” on page 73 macroinstructions.

For each resource type, the following bits are defined:

- One to indicate the usage of the resource is constrained
- One to indicate the usage is critical

If neither bit is set, the usage of the resource is considered normal. This allows CSM users to take action based on resource usage to prevent critical shortages that might jeopardize the application's or system's operation. Possible user actions might include selecting a different storage source for buffer pools or limiting usage of fixed storage. For information about other actions that an installation can consider to resolve resource shortages, see "Monitoring CSM storage" on page 2.

LOC	SOURCE STATEMENT	
000000	IVTSTATA DSECT	CSM resource status area
000000	STATA_ACRO DS CL4	Eyecatcher 'STAT'
000004	STATA_LEN DS XL2	Number of bytes of resource
	*	statistics
000006	STATA_FLAG DS X	Status flag
	STATA_ESTAT EQU X'C0'	ECSA storage status
	STATA_ECRIT EQU X'80'	ECSA storage critical
	STATA_ECONS EQU X'40'	ECSA storage constrained
	*	
	STATA_DSTAT EQU X'30'	Data space storage status
	STATA_DCRIT EQU X'20'	Data space storage
	*	critical
	STATA_DCONS EQU X'10'	Data space storage
	*	constrained
	*	
	STATA_FSTAT EQU X'0C'	Fixed storage status
	STATA_FCRIT EQU X'08'	Fixed storage critical
	STATA_FCONS EQU X'04'	Fixed storage constrained
000007	STATA_FLAG2 DS X	Misc - Flags
	STATA_MONITOR EQU X'80'	CSM Monitor active



---

## Appendix C. Related protocol specifications

This appendix lists the related protocol specifications (RFCs) for TCP/IP. The Internet Protocol suite is still evolving through requests for comments (RFC). New protocols are being designed and implemented by researchers and are brought to the attention of the Internet community in the form of RFCs. Some of these protocols are so useful that they become recommended protocols. That is, all future implementations for TCP/IP are recommended to implement these particular functions or protocols. These become the *de facto* standards, on which the TCP/IP protocol suite is built.

You can request RFCs through electronic mail, from the automated Network Information Center (NIC) mail server, by sending a message to `service@nic.ddn.mil` with a subject line of RFC *nnnn* for text versions or a subject line of RFC *nnnn*.PS for PostScript versions. To request a copy of the RFC index, send a message with a subject line of RFC INDEX.

For more information, contact `nic@nic.ddn.mil` or at:

Government Systems, Inc.  
Attn: Network Information Center  
14200 Park Meadow Drive  
Suite 200  
Chantilly, VA 22021

Hard copies of all RFCs are available from the NIC, either individually or by subscription. Online copies are available at the following Web address:  
<http://www.rfc-editor.org/rfc.html>.

Draft RFCs that have been implemented in this and previous Communications Server releases are listed at the end of this topic.

Many features of TCP/IP Services are based on the following RFCs:

**RFC Title and Author**

**RFC 652**

*Telnet output carriage-return disposition option* D. Crocker

**RFC 653**

*Telnet output horizontal tabstops option* D. Crocker

**RFC 654**

*Telnet output horizontal tab disposition option* D. Crocker

**RFC 655**

*Telnet output formfeed disposition option* D. Crocker

**RFC 657**

*Telnet output vertical tab disposition option* D. Crocker

**RFC 658**

*Telnet output linefeed disposition* D. Crocker

**RFC 698**

*Telnet extended ASCII option* T. Mock

- RFC 726**  
*Remote Controlled Transmission and Echoing Telnet option* J. Postel, D. Crocker
- RFC 727**  
*Telnet logout option* M.R. Crispin
- RFC 732**  
*Telnet Data Entry Terminal option* J.D. Day
- RFC 733**  
*Standard for the format of ARPA network text messages* D. Crocker, J. Vittal, K.T. Pogran, D.A. Henderson
- RFC 734**  
*SUPDUP Protocol* M.R. Crispin
- RFC 735**  
*Revised Telnet byte macro option* D. Crocker, R.H. Gumpertz
- RFC 736**  
*Telnet SUPDUP option* M.R. Crispin
- RFC 749**  
*Telnet SUPDUP—Output option* B. Greenberg
- RFC 765**  
*File Transfer Protocol specification* J. Postel
- RFC 768**  
*User Datagram Protocol* J. Postel
- RFC 779**  
*Telnet send-location option* E. Killian
- RFC 783**  
*TFTP Protocol (revision 2)* K.R. Sollins
- RFC 791**  
*Internet Protocol* J. Postel
- RFC 792**  
*Internet Control Message Protocol* J. Postel
- RFC 793**  
*Transmission Control Protocol* J. Postel
- RFC 820**  
*Assigned numbers* J. Postel
- RFC 821**  
*Simple Mail Transfer Protocol* J. Postel
- RFC 822**  
*Standard for the format of ARPA Internet text messages* D. Crocker
- RFC 823**  
*DARPA Internet gateway* R. Hinden, A. Sheltzer
- RFC 826**  
*Ethernet Address Resolution Protocol: Or converting network protocol addresses to 48.bit Ethernet address for transmission on Ethernet hardware* D. Plummer
- RFC 854**  
*Telnet Protocol Specification* J. Postel, J. Reynolds

- RFC 855**  
*Telnet Option Specification* J. Postel, J. Reynolds
- RFC 856**  
*Telnet Binary Transmission* J. Postel, J. Reynolds
- RFC 857**  
*Telnet Echo Option* J. Postel, J. Reynolds
- RFC 858**  
*Telnet Suppress Go Ahead Option* J. Postel, J. Reynolds
- RFC 859**  
*Telnet Status Option* J. Postel, J. Reynolds
- RFC 860**  
*Telnet Timing Mark Option* J. Postel, J. Reynolds
- RFC 861**  
*Telnet Extended Options: List Option* J. Postel, J. Reynolds
- RFC 862**  
*Echo Protocol* J. Postel
- RFC 863**  
*Discard Protocol* J. Postel
- RFC 864**  
*Character Generator Protocol* J. Postel
- RFC 865**  
*Quote of the Day Protocol* J. Postel
- RFC 868**  
*Time Protocol* J. Postel, K. Harrenstien
- RFC 877**  
*Standard for the transmission of IP datagrams over public data networks* J.T. Korb
- RFC 883**  
*Domain names: Implementation specification* P.V. Mockapetris
- RFC 884**  
*Telnet terminal type option* M. Solomon, E. Wimmers
- RFC 885**  
*Telnet end of record option* J. Postel
- RFC 894**  
*Standard for the transmission of IP datagrams over Ethernet networks* C. Hornig
- RFC 896**  
*Congestion control in IP/TCP internetworks* J. Nagle
- RFC 903**  
*Reverse Address Resolution Protocol* R. Finlayson, T. Mann, J. Mogul, M. Theimer
- RFC 904**  
*Exterior Gateway Protocol formal specification* D. Mills
- RFC 919**  
*Broadcasting Internet Datagrams* J. Mogul

- RFC 922**  
*Broadcasting Internet datagrams in the presence of subnets* J. Mogul
- RFC 927**  
*TACACS user identification Telnet option* B.A. Anderson
- RFC 933**  
*Output marking Telnet option* S. Silverman
- RFC 946**  
*Telnet terminal location number option* R. Nedved
- RFC 950**  
*Internet Standard Subnetting Procedure* J. Mogul, J. Postel
- RFC 952**  
*DoD Internet host table specification* K. Harrenstien, M. Stahl, E. Feinler
- RFC 959**  
*File Transfer Protocol* J. Postel, J.K. Reynolds
- RFC 961**  
*Official ARPA-Internet protocols* J.K. Reynolds, J. Postel
- RFC 974**  
*Mail routing and the domain system* C. Partridge
- RFC 1001**  
*Protocol standard for a NetBIOS service on a TCP/UDP transport: Concepts and methods* NetBios Working Group in the Defense Advanced Research Projects Agency, Internet Activities Board, End-to-End Services Task Force
- RFC 1002**  
*Protocol Standard for a NetBIOS service on a TCP/UDP transport: Detailed specifications* NetBios Working Group in the Defense Advanced Research Projects Agency, Internet Activities Board, End-to-End Services Task Force
- RFC 1006**  
*ISO transport services on top of the TCP: Version 3* M.T. Rose, D.E. Cass
- RFC 1009**  
*Requirements for Internet gateways* R. Braden, J. Postel
- RFC 1011**  
*Official Internet protocols* J. Reynolds, J. Postel
- RFC 1013**  
*X Window System Protocol, version 11: Alpha update April 1987* R. Scheifler
- RFC 1014**  
*XDR: External Data Representation standard* Sun Microsystems
- RFC 1027**  
*Using ARP to implement transparent subnet gateways* S. Carl-Mitchell, J. Quarterman
- RFC 1032**  
*Domain administrators guide* M. Stahl
- RFC 1033**  
*Domain administrators operations guide* M. Lottor
- RFC 1034**  
*Domain names—concepts and facilities* P.V. Mockapetris

- RFC 1035**  
*Domain names—implementation and specification* P.V. Mockapetris
- RFC 1038**  
*Draft revised IP security option* M. St. Johns
- RFC 1041**  
*Telnet 3270 regime option* Y. Rekhter
- RFC 1042**  
*Standard for the transmission of IP datagrams over IEEE 802 networks* J. Postel,  
J. Reynolds
- RFC 1043**  
*Telnet Data Entry Terminal option: DODIIS implementation* A. Yasuda, T.  
Thompson
- RFC 1044**  
*Internet Protocol on Network System's HYPERchannel: Protocol specification* K.  
Hardwick, J. Lekashman
- RFC 1053**  
*Telnet X.3 PAD option* S. Levy, T. Jacobson
- RFC 1055**  
*Nonstandard for transmission of IP datagrams over serial lines: SLIP* J. Romkey
- RFC 1057**  
*RPC: Remote Procedure Call Protocol Specification: Version 2* Sun Microsystems
- RFC 1058**  
*Routing Information Protocol* C. Hedrick
- RFC 1060**  
*Assigned numbers* J. Reynolds, J. Postel
- RFC 1067**  
*Simple Network Management Protocol* J.D. Case, M. Fedor, M.L. Schoffstall, J.  
Davin
- RFC 1071**  
*Computing the Internet checksum* R.T. Braden, D.A. Borman, C. Partridge
- RFC 1072**  
*TCP extensions for long-delay paths* V. Jacobson, R.T. Braden
- RFC 1073**  
*Telnet window size option* D. Waitzman
- RFC 1079**  
*Telnet terminal speed option* C. Hedrick
- RFC 1085**  
*ISO presentation services on top of TCP/IP based internets* M.T. Rose
- RFC 1091**  
*Telnet terminal-type option* J. VanBokkelen
- RFC 1094**  
*NFS: Network File System Protocol specification* Sun Microsystems
- RFC 1096**  
*Telnet X display location option* G. Marcy
- RFC 1101**  
*DNS encoding of network names and other types* P. Mockapetris

- RFC 1112**  
*Host extensions for IP multicasting* S.E. Deering
- RFC 1113**  
*Privacy enhancement for Internet electronic mail: Part I — message encipherment and authentication procedures* J. Linn
- RFC 1118**  
*Hitchhikers Guide to the Internet* E. Krol
- RFC 1122**  
*Requirements for Internet Hosts—Communication Layers* R. Braden, Ed.
- RFC 1123**  
*Requirements for Internet Hosts—Application and Support* R. Braden, Ed.
- RFC 1146**  
*TCP alternate checksum options* J. Zweig, C. Partridge
- RFC 1155**  
*Structure and identification of management information for TCP/IP-based internets* M. Rose, K. McCloghrie
- RFC 1156**  
*Management Information Base for network management of TCP/IP-based internets* K. McCloghrie, M. Rose
- RFC 1157**  
*Simple Network Management Protocol (SNMP)* J. Case, M. Fedor, M. Schoffstall, J. Davin
- RFC 1158**  
*Management Information Base for network management of TCP/IP-based internets: MIB-II* M. Rose
- RFC 1166**  
*Internet numbers* S. Kirkpatrick, M.K. Stahl, M. Recker
- RFC 1179**  
*Line printer daemon protocol* L. McLaughlin
- RFC 1180**  
*TCP/IP tutorial* T. Socolofsky, C. Kale
- RFC 1183**  
*New DNS RR Definitions* C.F. Everhart, L.A. Mamakos, R. Ullmann, P.V. Mockapetris
- RFC 1184**  
*Telnet Linemode Option* D. Borman
- RFC 1186**  
*MD4 Message Digest Algorithm* R.L. Rivest
- RFC 1187**  
*Bulk Table Retrieval with the SNMP* M. Rose, K. McCloghrie, J. Davin
- RFC 1188**  
*Proposed Standard for the Transmission of IP Datagrams over FDDI Networks* D. Katz
- RFC 1190**  
*Experimental Internet Stream Protocol: Version 2 (ST-II)* C. Topolcic

- RFC 1191**  
*Path MTU discovery* J. Mogul, S. Deering
- RFC 1198**  
*FYI on the X window system* R. Scheifler
- RFC 1207**  
*FYI on Questions and Answers: Answers to commonly asked "experienced Internet user" questions* G. Malkin, A. Marine, J. Reynolds
- RFC 1208**  
*Glossary of networking terms* O. Jacobsen, D. Lynch
- RFC 1213**  
*Management Information Base for Network Management of TCP/IP-based internets: MIB-II* K. McCloghrie, M.T. Rose
- RFC 1215**  
*Convention for defining traps for use with the SNMP* M. Rose
- RFC 1227**  
*SNMP MUX protocol and MIB* M.T. Rose
- RFC 1228**  
*SNMP-DPI: Simple Network Management Protocol Distributed Program Interface*  
G. Carpenter, B. Wijnen
- RFC 1229**  
*Extensions to the generic-interface MIB* K. McCloghrie
- RFC 1230**  
*IEEE 802.4 Token Bus MIB* K. McCloghrie, R. Fox
- RFC 1231**  
*IEEE 802.5 Token Ring MIB* K. McCloghrie, R. Fox, E. Decker
- RFC 1236**  
*IP to X.121 address mapping for DDN* L. Morales, P. Hasse
- RFC 1256**  
*ICMP Router Discovery Messages* S. Deering, Ed.
- RFC 1267**  
*Border Gateway Protocol 3 (BGP-3)* K. Lougheed, Y. Rekhter
- RFC 1268**  
*Application of the Border Gateway Protocol in the Internet* Y. Rekhter, P. Gross
- RFC 1269**  
*Definitions of Managed Objects for the Border Gateway Protocol: Version 3* S. Willis, J. Burruss
- RFC 1270**  
*SNMP Communications Services* F. Kastenholz, ed.
- RFC 1285**  
*FDDI Management Information Base* J. Case
- RFC 1315**  
*Management Information Base for Frame Relay DTEs* C. Brown, F. Baker, C. Carvalho
- RFC 1321**  
*The MD5 Message-Digest Algorithm* R. Rivest

- RFC 1323**  
*TCP Extensions for High Performance* V. Jacobson, R. Braden, D. Borman
- RFC 1325**  
*FYI on Questions and Answers: Answers to Commonly Asked "New Internet User" Questions* G. Malkin, A. Marine
- RFC 1327**  
*Mapping between X.400 (1988)/ISO 10021 and RFC 822* S. Hardcastle-Kille
- RFC 1340**  
*Assigned Numbers* J. Reynolds, J. Postel
- RFC 1344**  
*Implications of MIME for Internet Mail Gateways* N. Bornstein
- RFC 1349**  
*Type of Service in the Internet Protocol Suite* P. Almquist
- RFC 1350**  
*The TFTP Protocol (Revision 2)* K.R. Sollins
- RFC 1351**  
*SNMP Administrative Model* J. Davin, J. Galvin, K. McCloghrie
- RFC 1352**  
*SNMP Security Protocols* J. Galvin, K. McCloghrie, J. Davin
- RFC 1353**  
*Definitions of Managed Objects for Administration of SNMP Parties* K. McCloghrie, J. Davin, J. Galvin
- RFC 1354**  
*IP Forwarding Table MIB* F. Baker
- RFC 1356**  
*Multiprotocol Interconnect on X.25 and ISDN in the Packet Mode* A. Malis, D. Robinson, R. Ullmann
- RFC 1358**  
*Charter of the Internet Architecture Board (IAB)* L. Chapin
- RFC 1363**  
*A Proposed Flow Specification* C. Partridge
- RFC 1368**  
*Definition of Managed Objects for IEEE 802.3 Repeater Devices* D. McMaster, K. McCloghrie
- RFC 1372**  
*Telnet Remote Flow Control Option* C. L. Hedrick, D. Borman
- RFC 1374**  
*IP and ARP on HIPPI* J. Renwick, A. Nicholson
- RFC 1381**  
*SNMP MIB Extension for X.25 LAPB* D. Throop, F. Baker
- RFC 1382**  
*SNMP MIB Extension for the X.25 Packet Layer* D. Throop
- RFC 1387**  
*RIP Version 2 Protocol Analysis* G. Malkin
- RFC 1388**  
*RIP Version 2 Carrying Additional Information* G. Malkin



- RFC 1389**  
*RIP Version 2 MIB Extensions* G. Malkin, F. Baker
- RFC 1390**  
*Transmission of IP and ARP over FDDI Networks* D. Katz
- RFC 1393**  
*Traceroute Using an IP Option* G. Malkin
- RFC 1398**  
*Definitions of Managed Objects for the Ethernet-Like Interface Types* F. Kastenholz
- RFC 1408**  
*Telnet Environment Option* D. Borman, Ed.
- RFC 1413**  
*Identification Protocol* M. St. Johns
- RFC 1416**  
*Telnet Authentication Option* D. Borman, ed.
- RFC 1420**  
*SNMP over IPX* S. Bostock
- RFC 1428**  
*Transition of Internet Mail from Just-Send-8 to 8bit-SMTP/MIME* G. Vaudreuil
- RFC 1442**  
*Structure of Management Information for version 2 of the Simple Network Management Protocol (SNMPv2)* J. Case, K. McCloghrie, M. Rose, S. Waldbusser
- RFC 1443**  
*Textual Conventions for version 2 of the Simple Network Management Protocol (SNMPv2)* J. Case, K. McCloghrie, M. Rose, S. Waldbusser
- RFC 1445**  
*Administrative Model for version 2 of the Simple Network Management Protocol (SNMPv2)* J. Galvin, K. McCloghrie
- RFC 1447**  
*Party MIB for version 2 of the Simple Network Management Protocol (SNMPv2)* K. McCloghrie, J. Galvin
- RFC 1448**  
*Protocol Operations for version 2 of the Simple Network Management Protocol (SNMPv2)* J. Case, K. McCloghrie, M. Rose, S. Waldbusser
- RFC 1464**  
*Using the Domain Name System to Store Arbitrary String Attributes* R. Rosenbaum
- RFC 1469**  
*IP Multicast over Token-Ring Local Area Networks* T. Pusateri
- RFC 1483**  
*Multiprotocol Encapsulation over ATM Adaptation Layer 5* Juha Heinanen
- RFC 1514**  
*Host Resources MIB* P. Grillo, S. Waldbusser
- RFC 1516**  
*Definitions of Managed Objects for IEEE 802.3 Repeater Devices* D. McMaster, K. McCloghrie

- RFC 1521**  
*MIME (Multipurpose Internet Mail Extensions) Part One: Mechanisms for Specifying and Describing the Format of Internet Message Bodies* N. Borenstein, N. Freed
- RFC 1535**  
*A Security Problem and Proposed Correction With Widely Deployed DNS Software* E. Gavron
- RFC 1536**  
*Common DNS Implementation Errors and Suggested Fixes* A. Kumar, J. Postel, C. Neuman, P. Danzig, S. Miller
- RFC 1537**  
*Common DNS Data File Configuration Errors* P. Beertema
- RFC 1540**  
*Internet Official Protocol Standards* J. Postel
- RFC 1571**  
*Telnet Environment Option Interoperability Issues* D. Borman
- RFC 1572**  
*Telnet Environment Option* S. Alexander
- RFC 1573**  
*Evolution of the Interfaces Group of MIB-II* K. McCloghrie, F. Kastenholz
- RFC 1577**  
*Classical IP and ARP over ATM* M. Laubach
- RFC 1583**  
*OSPF Version 2* J. Moy
- RFC 1591**  
*Domain Name System Structure and Delegation* J. Postel
- RFC 1592**  
*Simple Network Management Protocol Distributed Protocol Interface Version 2.0* B. Wijnen, G. Carpenter, K. Curran, A. Sehgal, G. Waters
- RFC 1594**  
*FYI on Questions and Answers—Answers to Commonly Asked "New Internet User" Questions* A. Marine, J. Reynolds, G. Malkin
- RFC 1644**  
*T/TCP — TCP Extensions for Transactions Functional Specification* R. Braden
- RFC 1646**  
*TN3270 Extensions for LUname and Printer Selection* C. Graves, T. Butts, M. Angel
- RFC 1647**  
*TN3270 Enhancements* B. Kelly
- RFC 1652**  
*SMTP Service Extension for 8bit-MIMEtransport* J. Klensin, N. Freed, M. Rose, E. Stefferud, D. Crocker
- RFC 1664**  
*Using the Internet DNS to Distribute RFC1327 Mail Address Mapping Tables* C. Allochio, A. Bonito, B. Cole, S. Giordano, R. Hagens
- RFC 1693**  
*An Extension to TCP: Partial Order Service* T. Connolly, P. Amer, P. Conrad

- RFC 1695**  
*Definitions of Managed Objects for ATM Management Version 8.0 using SMIPv2*  
M. Ahmed, K. Tesink
- RFC 1701**  
*Generic Routing Encapsulation (GRE)* S. Hanks, T. Li, D. Farinacci, P. Traina
- RFC 1702**  
*Generic Routing Encapsulation over IPv4 networks* S. Hanks, T. Li, D. Farinacci, P. Traina
- RFC 1706**  
*DNS NSAP Resource Records* B. Manning, R. Colella
- RFC 1712**  
*DNS Encoding of Geographical Location* C. Farrell, M. Schulze, S. Pleitner D. Baldoni
- RFC 1713**  
*Tools for DNS debugging* A. Romao
- RFC 1723**  
*RIP Version 2—Carrying Additional Information* G. Malkin
- RFC 1752**  
*The Recommendation for the IP Next Generation Protocol* S. Bradner, A. Mankin
- RFC 1766**  
*Tags for the Identification of Languages* H. Alvestrand
- RFC 1771**  
*A Border Gateway Protocol 4 (BGP-4)* Y. Rekhter, T. Li
- RFC 1794**  
*DNS Support for Load Balancing* T. Brisco
- RFC 1819**  
*Internet Stream Protocol Version 2 (ST2) Protocol Specification—Version ST2+* L. Delgrossi, L. Berger Eds.
- RFC 1826**  
*IP Authentication Header* R. Atkinson
- RFC 1828**  
*IP Authentication using Keyed MD5* P. Metzger, W. Simpson
- RFC 1829**  
*The ESP DES-CBC Transform* P. Karn, P. Metzger, W. Simpson
- RFC 1830**  
*SMTP Service Extensions for Transmission of Large and Binary MIME Messages*  
G. Vaudreuil
- RFC 1831**  
*RPC: Remote Procedure Call Protocol Specification Version 2* R. Srinivasan
- RFC 1832**  
*XDR: External Data Representation Standard* R. Srinivasan
- RFC 1833**  
*Binding Protocols for ONC RPC Version 2* R. Srinivasan
- RFC 1850**  
*OSPF Version 2 Management Information Base* F. Baker, R. Coltun

- RFC 1854**  
*SMTP Service Extension for Command Pipelining* N. Freed
- RFC 1869**  
*SMTP Service Extensions* J. Klensin, N. Freed, M. Rose, E. Stefferud, D. Crocker
- RFC 1870**  
*SMTP Service Extension for Message Size Declaration* J. Klensin, N. Freed, K. Moore
- RFC 1876**  
*A Means for Expressing Location Information in the Domain Name System* C. Davis, P. Vixie, T. Goodwin, I. Dickinson
- RFC 1883**  
*Internet Protocol, Version 6 (IPv6) Specification* S. Deering, R. Hinden
- RFC 1884**  
*IP Version 6 Addressing Architecture* R. Hinden, S. Deering, Eds.
- RFC 1886**  
*DNS Extensions to support IP version 6* S. Thomson, C. Huitema
- RFC 1888**  
*OSI NSAPs and IPv6* J. Bound, B. Carpenter, D. Harrington, J. Houldsworth, A. Lloyd
- RFC 1891**  
*SMTP Service Extension for Delivery Status Notifications* K. Moore
- RFC 1892**  
*The Multipart/Report Content Type for the Reporting of Mail System Administrative Messages* G. Vaudreuil
- RFC 1894**  
*An Extensible Message Format for Delivery Status Notifications* K. Moore, G. Vaudreuil
- RFC 1901**  
*Introduction to Community-based SNMPv2* J. Case, K. McCloaghrie, M. Rose, S. Waldbusser
- RFC 1902**  
*Structure of Management Information for Version 2 of the Simple Network Management Protocol (SNMPv2)* J. Case, K. McCloaghrie, M. Rose, S. Waldbusser
- RFC 1903**  
*Textual Conventions for Version 2 of the Simple Network Management Protocol (SNMPv2)* J. Case, K. McCloaghrie, M. Rose, S. Waldbusser
- RFC 1904**  
*Conformance Statements for Version 2 of the Simple Network Management Protocol (SNMPv2)* J. Case, K. McCloaghrie, M. Rose, S. Waldbusser
- RFC 1905**  
*Protocol Operations for Version 2 of the Simple Network Management Protocol (SNMPv2)* J. Case, K. McCloaghrie, M. Rose, S. Waldbusser
- RFC 1906**  
*Transport Mappings for Version 2 of the Simple Network Management Protocol (SNMPv2)* J. Case, K. McCloaghrie, M. Rose, S. Waldbusser

- RFC 1907**  
*Management Information Base for Version 2 of the Simple Network Management Protocol (SNMPv2)* J. Case, K. McCloghrie, M. Rose, S. Waldbusser
- RFC 1908**  
*Coexistence between Version 1 and Version 2 of the Internet-standard Network Management Framework* J. Case, K. McCloghrie, M. Rose, S. Waldbusser
- RFC 1912**  
*Common DNS Operational and Configuration Errors* D. Barr
- RFC 1918**  
*Address Allocation for Private Internets* Y. Rekhter, B. Moskowitz, D. Karrenberg, G.J. de Groot, E. Lear
- RFC 1928**  
*SOCKS Protocol Version 5* M. Leech, M. Ganis, Y. Lee, R. Kuris, D. Koblas, L. Jones
- RFC 1930**  
*Guidelines for creation, selection, and registration of an Autonomous System (AS)* J. Hawkinson, T. Bates
- RFC 1939**  
*Post Office Protocol-Version 3* J. Myers, M. Rose
- RFC 1981**  
*Path MTU Discovery for IP version 6* J. McCann, S. Deering, J. Mogul
- RFC 1982**  
*Serial Number Arithmetic* R. Elz, R. Bush
- RFC 1985**  
*SMTP Service Extension for Remote Message Queue Starting* J. De Winter
- RFC 1995**  
*Incremental Zone Transfer in DNS* M. Ohta
- RFC 1996**  
*A Mechanism for Prompt Notification of Zone Changes (DNS NOTIFY)* P. Vixie
- RFC 2010**  
*Operational Criteria for Root Name Servers* B. Manning, P. Vixie
- RFC 2011**  
*SNMPv2 Management Information Base for the Internet Protocol using SMIPv2* K. McCloghrie, Ed.
- RFC 2012**  
*SNMPv2 Management Information Base for the Transmission Control Protocol using SMIPv2* K. McCloghrie, Ed.
- RFC 2013**  
*SNMPv2 Management Information Base for the User Datagram Protocol using SMIPv2* K. McCloghrie, Ed.
- RFC 2018**  
*TCP Selective Acknowledgement Options* M. Mathis, J. Mahdavi, S. Floyd, A. Romanow
- RFC 2026**  
*The Internet Standards Process — Revision 3* S. Bradner

- RFC 2030**  
*Simple Network Time Protocol (SNTP) Version 4 for IPv4, IPv6 and OSI D.*  
Mills
- RFC 2033**  
*Local Mail Transfer Protocol* J. Myers
- RFC 2034**  
*SMTP Service Extension for Returning Enhanced Error Codes* N. Freed
- RFC 2040**  
*The RC5, RC5–CBC, RC5–CBC–Pad, and RC5–CTS Algorithms* R. Baldwin, R. Rivest
- RFC 2045**  
*Multipurpose Internet Mail Extensions (MIME) Part One: Format of Internet Message Bodies* N. Freed, N. Borenstein
- RFC 2052**  
*A DNS RR for specifying the location of services (DNS SRV)* A. Gulbrandsen, P. Vixie
- RFC 2065**  
*Domain Name System Security Extensions* D. Eastlake 3rd, C. Kaufman
- RFC 2066**  
*TELNET CHARSET Option* R. Gellens
- RFC 2080**  
*RIPng for IPv6* G. Malkin, R. Minnear
- RFC 2096**  
*IP Forwarding Table MIB* F. Baker
- RFC 2104**  
*HMAC: Keyed-Hashing for Message Authentication* H. Krawczyk, M. Bellare, R. Canetti
- RFC 2119**  
*Keywords for use in RFCs to Indicate Requirement Levels* S. Bradner
- RFC 2133**  
*Basic Socket Interface Extensions for IPv6* R. Gilligan, S. Thomson, J. Bound, W. Stevens
- RFC 2136**  
*Dynamic Updates in the Domain Name System (DNS UPDATE)* P. Vixie, Ed., S. Thomson, Y. Rekhter, J. Bound
- RFC 2137**  
*Secure Domain Name System Dynamic Update* D. Eastlake 3rd
- RFC 2163**  
*Using the Internet DNS to Distribute MIXER Conformant Global Address Mapping (MCGAM)* C. Allocchio
- RFC 2168**  
*Resolution of Uniform Resource Identifiers using the Domain Name System* R. Daniel, M. Mealling
- RFC 2178**  
*OSPF Version 2* J. Moy
- RFC 2181**  
*Clarifications to the DNS Specification* R. Elz, R. Bush

- RFC 2205**  
*Resource ReSerVation Protocol (RSVP)—Version 1 Functional Specification* R. Braden, Ed., L. Zhang, S. Berson, S. Herzog, S. Jamin
- RFC 2210**  
*The Use of RSVP with IETF Integrated Services* J. Wroclawski
- RFC 2211**  
*Specification of the Controlled-Load Network Element Service* J. Wroclawski
- RFC 2212**  
*Specification of Guaranteed Quality of Service* S. Shenker, C. Partridge, R. Guerin
- RFC 2215**  
*General Characterization Parameters for Integrated Service Network Elements* S. Shenker, J. Wroclawski
- RFC 2217**  
*Telnet Com Port Control Option* G. Clarke
- RFC 2219**  
*Use of DNS Aliases for Network Services* M. Hamilton, R. Wright
- RFC 2228**  
*FTP Security Extensions* M. Horowitz, S. Lunt
- RFC 2230**  
*Key Exchange Delegation Record for the DNS* R. Atkinson
- RFC 2233**  
*The Interfaces Group MIB using SMIPv2* K. McCloghrie, F. Kastenholz
- RFC 2240**  
*A Legal Basis for Domain Name Allocation* O. Vaughn
- RFC 2246**  
*The TLS Protocol Version 1.0* T. Dierks, C. Allen
- RFC 2251**  
*Lightweight Directory Access Protocol (v3)* M. Wahl, T. Howes, S. Kille
- RFC 2253**  
*Lightweight Directory Access Protocol (v3): UTF-8 String Representation of Distinguished Names* M. Wahl, S. Kille, T. Howes
- RFC 2254**  
*The String Representation of LDAP Search Filters* T. Howes
- RFC 2261**  
*An Architecture for Describing SNMP Management Frameworks* D. Harrington, R. Presuhn, B. Wijnen
- RFC 2262**  
*Message Processing and Dispatching for the Simple Network Management Protocol (SNMP)* J. Case, D. Harrington, R. Presuhn, B. Wijnen
- RFC 2271**  
*An Architecture for Describing SNMP Management Frameworks* D. Harrington, R. Presuhn, B. Wijnen
- RFC 2273**  
*SNMPv3 Applications* D. Levi, P. Meyer, B. Stewart

- RFC 2274**  
*User-based Security Model (USM) for version 3 of the Simple Network Management Protocol (SNMPv3)* U. Blumenthal, B. Wijnen
- RFC 2275**  
*View-based Access Control Model (VACM) for the Simple Network Management Protocol (SNMP)* B. Wijnen, R. Presuhn, K. McCloghrie
- RFC 2279**  
*UTF-8, a transformation format of ISO 10646* F. Yergeau
- RFC 2292**  
*Advanced Sockets API for IPv6* W. Stevens, M. Thomas
- RFC 2308**  
*Negative Caching of DNS Queries (DNS NCACHE)* M. Andrews
- RFC 2317**  
*Classless IN-ADDR.ARPA delegation* H. Eidnes, G. de Groot, P. Vixie
- RFC 2320**  
*Definitions of Managed Objects for Classical IP and ARP Over ATM Using SMIv2 (IPOA-MIB)* M. Greene, J. Luciani, K. White, T. Kuo
- RFC 2328**  
*OSPF Version 2* J. Moy
- RFC 2345**  
*Domain Names and Company Name Retrieval* J. Klensin, T. Wolf, G. Oglesby
- RFC 2352**  
*A Convention for Using Legal Names as Domain Names* O. Vaughn
- RFC 2355**  
*TN3270 Enhancements* B. Kelly
- RFC 2358**  
*Definitions of Managed Objects for the Ethernet-like Interface Types* J. Flick, J. Johnson
- RFC 2373**  
*IP Version 6 Addressing Architecture* R. Hinden, S. Deering
- RFC 2374**  
*An IPv6 Aggregatable Global Unicast Address Format* R. Hinden, M. O'Dell, S. Deering
- RFC 2375**  
*IPv6 Multicast Address Assignments* R. Hinden, S. Deering
- RFC 2385**  
*Protection of BGP Sessions via the TCP MD5 Signature Option* A. Hefferman
- RFC 2389**  
*Feature negotiation mechanism for the File Transfer Protocol* P. Hethmon, R. Elz
- RFC 2401**  
*Security Architecture for Internet Protocol* S. Kent, R. Atkinson
- RFC 2402**  
*IP Authentication Header* S. Kent, R. Atkinson
- RFC 2403**  
*The Use of HMAC-MD5-96 within ESP and AH* C. Madson, R. Glenn



- RFC 2404**  
*The Use of HMAC-SHA-1-96 within ESP and AH* C. Madson, R. Glenn
- RFC 2405**  
*The ESP DES-CBC Cipher Algorithm With Explicit IV* C. Madson, N. Doraswamy
- RFC 2406**  
*IP Encapsulating Security Payload (ESP)* S. Kent, R. Atkinson
- RFC 2407**  
*The Internet IP Security Domain of Interpretation for ISAKMPD*. Piper
- RFC 2408**  
*Internet Security Association and Key Management Protocol (ISAKMP)* D. Maughan, M. Schertler, M. Schneider, J. Turner
- RFC 2409**  
*The Internet Key Exchange (IKE)* D. Harkins, D. Carrel
- RFC 2410**  
*The NULL Encryption Algorithm and Its Use With IPsec* R. Glenn, S. Kent,
- RFC 2428**  
*FTP Extensions for IPv6 and NATs* M. Allman, S. Ostermann, C. Metz
- RFC 2445**  
*Internet Calendaring and Scheduling Core Object Specification (iCalendar)* F. Dawson, D. Stenerson
- RFC 2459**  
*Internet X.509 Public Key Infrastructure Certificate and CRL Profile* R. Housley, W. Ford, W. Polk, D. Solo
- RFC 2460**  
*Internet Protocol, Version 6 (IPv6) Specification* S. Deering, R. Hinden
- RFC 2461**  
*Neighbor Discovery for IP Version 6 (IPv6)* T. Narten, E. Nordmark, W. Simpson
- RFC 2462**  
*IPv6 Stateless Address Autoconfiguration* S. Thomson, T. Narten
- RFC 2463**  
*Internet Control Message Protocol (ICMPv6) for the Internet Protocol Version 6 (IPv6) Specification* A. Conta, S. Deering
- RFC 2464**  
*Transmission of IPv6 Packets over Ethernet Networks* M. Crawford
- RFC 2466**  
*Management Information Base for IP Version 6: ICMPv6 Group* D. Haskin, S. Onishi
- RFC 2476**  
*Message Submission* R. Gellens, J. Klensin
- RFC 2487**  
*SMTP Service Extension for Secure SMTP over TLS* P. Hoffman
- RFC 2505**  
*Anti-Spam Recommendations for SMTP MTAs* G. Lindberg

- RFC 2523**  
*Photuris: Extended Schemes and Attributes* P. Karn, W. Simpson
- RFC 2535**  
*Domain Name System Security Extensions* D. Eastlake 3rd
- RFC 2538**  
*Storing Certificates in the Domain Name System (DNS)* D. Eastlake 3rd, O. Gudmundsson
- RFC 2539**  
*Storage of Diffie-Hellman Keys in the Domain Name System (DNS)* D. Eastlake 3rd
- RFC 2540**  
*Detached Domain Name System (DNS) Information* D. Eastlake 3rd
- RFC 2554**  
*SMTP Service Extension for Authentication* J. Myers
- RFC 2570**  
*Introduction to Version 3 of the Internet-standard Network Management Framework* J. Case, R. Mundy, D. Partain, B. Stewart
- RFC 2571**  
*An Architecture for Describing SNMP Management Frameworks* B. Wijnen, D. Harrington, R. Presuhn
- RFC 2572**  
*Message Processing and Dispatching for the Simple Network Management Protocol (SNMP)* J. Case, D. Harrington, R. Presuhn, B. Wijnen
- RFC 2573**  
*SNMP Applications* D. Levi, P. Meyer, B. Stewart
- RFC 2574**  
*User-based Security Model (USM) for version 3 of the Simple Network Management Protocol (SNMPv3)* U. Blumenthal, B. Wijnen
- RFC 2575**  
*View-based Access Control Model (VACM) for the Simple Network Management Protocol (SNMP)* B. Wijnen, R. Presuhn, K. McCloghrie
- RFC 2576**  
*Co-Existence between Version 1, Version 2, and Version 3 of the Internet-standard Network Management Framework* R. Frye, D. Levi, S. Routhier, B. Wijnen
- RFC 2578**  
*Structure of Management Information Version 2 (SMIPv2)* K. McCloghrie, D. Perkins, J. Schoenwaelder
- RFC 2579**  
*Textual Conventions for SMIPv2* K. McCloghrie, D. Perkins, J. Schoenwaelder
- RFC 2580**  
*Conformance Statements for SMIPv2* K. McCloghrie, D. Perkins, J. Schoenwaelder
- RFC 2581**  
*TCP Congestion Control* M. Allman, V. Paxson, W. Stevens
- RFC 2583**  
*Guidelines for Next Hop Client (NHC) Developers* R. Carlson, L. Winkler

- RFC 2591**  
*Definitions of Managed Objects for Scheduling Management Operations* D. Levi,  
J. Schoenwaelder
- RFC 2625**  
*IP and ARP over Fibre Channel* M. Rajagopal, R. Bhagwat, W. Rickard
- RFC 2635**  
*Don't SPEW A Set of Guidelines for Mass Unsolicited Mailings and Postings  
(spam\*)* S. Hambridge, A. Lunde
- RFC 2637**  
*Point-to-Point Tunneling Protocol* K. Hamzeh, G. Pall, W. Verthein, J. Taarud,  
W. Little, G. Zorn
- RFC 2640**  
*Internationalization of the File Transfer Protocol* B. Curtin
- RFC 2665**  
*Definitions of Managed Objects for the Ethernet-like Interface Types* J. Flick, J.  
Johnson
- RFC 2671**  
*Extension Mechanisms for DNS (EDNS0)* P. Vixie
- RFC 2672**  
*Non-Terminal DNS Name Redirection* M. Crawford
- RFC 2675**  
*IPv6 Jumbograms* D. Borman, S. Deering, R. Hinden
- RFC 2710**  
*Multicast Listener Discovery (MLD) for IPv6* S. Deering, W. Fenner, B.  
Haberman
- RFC 2711**  
*IPv6 Router Alert Option* C. Partridge, A. Jackson
- RFC 2740**  
*OSPF for IPv6* R. Coltun, D. Ferguson, J. Moy
- RFC 2753**  
*A Framework for Policy-based Admission Control* R. Yavatkar, D. Pendarakis,  
R. Guerin
- RFC 2782**  
*A DNS RR for specifying the location of services (DNS SRV)* A. Gubrandsen, P.  
Vixix, L. Esibov
- RFC 2821**  
*Simple Mail Transfer Protocol* J. Klensin, Ed.
- RFC 2822**  
*Internet Message Format* P. Resnick, Ed.
- RFC 2840**  
*TELNET KERMIT OPTION* J. Altman, F. da Cruz
- RFC 2845**  
*Secret Key Transaction Authentication for DNS (TSIG)* P. Vixie, O.  
Gudmundsson, D. Eastlake 3rd, B. Wellington
- RFC 2851**  
*Textual Conventions for Internet Network Addresses* M. Daniele, B. Haberman,  
S. Routhier, J. Schoenwaelder

- RFC 2852**  
*Deliver By SMTP Service Extension* D. Newman
- RFC 2874**  
*DNS Extensions to Support IPv6 Address Aggregation and Renumbering* M. Crawford, C. Huitema
- RFC 2915**  
*The Naming Authority Pointer (NAPTR) DNS Resource Record* M. Mealling, R. Daniel
- RFC 2920**  
*SMTP Service Extension for Command Pipelining* N. Freed
- RFC 2930**  
*Secret Key Establishment for DNS (TKEY RR)* D. Eastlake, 3rd
- RFC 2941**  
*Telnet Authentication Option* T. Ts'o, ed., J. Altman
- RFC 2942**  
*Telnet Authentication: Kerberos Version 5* T. Ts'o
- RFC 2946**  
*Telnet Data Encryption Option* T. Ts'o
- RFC 2952**  
*Telnet Encryption: DES 64 bit Cipher Feedback* T. Ts'o
- RFC 2953**  
*Telnet Encryption: DES 64 bit Output Feedback* T. Ts'o
- RFC 2992**  
*Analysis of an Equal-Cost Multi-Path Algorithm* C. Hopps
- RFC 3019**  
*IP Version 6 Management Information Base for The Multicast Listener Discovery Protocol* B. Haberman, R. Worzella
- RFC 3060**  
*Policy Core Information Model—Version 1 Specification* B. Moore, E. Ellesson, J. Strassner, A. Westerinen
- RFC 3152**  
*Delegation of IP6.ARPA* R. Bush
- RFC 3164**  
*The BSD Syslog Protocol* C. Lonvick
- RFC 3207**  
*SMTP Service Extension for Secure SMTP over Transport Layer Security* P. Hoffman
- RFC 3226**  
*DNSSEC and IPv6 A6 aware server/resolver message size requirements* O. Gudmundsson
- RFC 3291**  
*Textual Conventions for Internet Network Addresses* M. Daniele, B. Haberman, S. Routhier, J. Schoenwaelder
- RFC 3363**  
*Representing Internet Protocol version 6 (IPv6) Addresses in the Domain Name System* R. Bush, A. Durand, B. Fink, O. Gudmundsson, T. Hain

- RFC 3376**  
*Internet Group Management Protocol, Version 3* B. Cain, S. Deering, I. Kouvelas, B. Fenner, A. Thyagarajan
- RFC 3390**  
*Increasing TCP's Initial Window* M. Allman, S. Floyd, C. Partridge
- RFC 3410**  
*Introduction and Applicability Statements for Internet-Standard Management Framework* J. Case, R. Mundy, D. Partain, B. Stewart
- RFC 3411**  
*An Architecture for Describing Simple Network Management Protocol (SNMP) Management Frameworks* D. Harrington, R. Presuhn, B. Wijnen
- RFC 3412**  
*Message Processing and Dispatching for the Simple Network Management Protocol (SNMP)* J. Case, D. Harrington, R. Presuhn, B. Wijnen
- RFC 3413**  
*Simple Network Management Protocol (SNMP) Applications* D. Levi, P. Meyer, B. Stewart
- RFC 3414**  
*User-based Security Model (USM) for version 3 of the Simple Network Management Protocol (SNMPv3)* U. Blumenthal, B. Wijnen
- RFC 3415**  
*View-based Access Control Model (VACM) for the Simple Network Management Protocol (SNMP)* B. Wijnen, R. Presuhn, K. McCloghrie
- RFC 3416**  
*Version 2 of the Protocol Operations for the Simple Network Management Protocol (SNMP)* R. Presuhn, J. Case, K. McCloghrie, M. Rose, S. Waldbusser
- RFC 3417**  
*Transport Mappings for the Simple Network Management Protocol (SNMP)* R. Presuhn, J. Case, K. McCloghrie, M. Rose, S. Waldbusser
- RFC 3418**  
*Management Information Base (MIB) for the Simple Network Management Protocol (SNMP)* R. Presuhn, J. Case, K. McCloghrie, M. Rose, S. Waldbusser
- RFC 3419**  
*Textual Conventions for Transport Addresses* M. Daniele, J. Schoenwaelder
- RFC 3484**  
*Default Address Selection for Internet Protocol version 6 (IPv6)* R. Draves
- RFC 3493**  
*Basic Socket Interface Extensions for IPv6* R. Gilligan, S. Thomson, J. Bound, J. McCann, W. Stevens
- RFC 3513**  
*Internet Protocol Version 6 (IPv6) Addressing Architecture* R. Hinden, S. Deering
- RFC 3526**  
*More Modular Exponential (MODP) Diffie-Hellman groups for Internet Key Exchange (IKE)* T. Kivinen, M. Kojo

- RFC 3542**  
*Advanced Sockets Application Programming Interface (API) for IPv6* W. Richard Stevens, M. Thomas, E. Nordmark, T. Jinmei
- RFC 3566**  
*The AES-XCBC-MAC-96 Algorithm and Its Use With IPsec* S. Frankel, H. Herbert
- RFC 3569**  
*An Overview of Source-Specific Multicast (SSM)* S. Bhattacharyya, Ed.
- RFC 3584**  
*Coexistence between Version 1, Version 2, and Version 3 of the Internet-standard Network Management Framework* R. Frye, D. Levi, S. Routhier, B. Wijnen
- RFC 3602**  
*The AES-CBC Cipher Algorithm and Its Use with IPsec* S. Frankel, R. Glenn, S. Kelly
- RFC 3629**  
*UTF-8, a transformation format of ISO 10646* R. Kermode, C. Vicisano
- RFC 3658**  
*Delegation Signer (DS) Resource Record (RR)* O. Gudmundsson
- RFC 3678**  
*Socket Interface Extensions for Multicast Source Filters* D. Thaler, B. Fenner, B. Quinn
- RFC 3715**  
*IPsec-Network Address Translation (NAT) Compatibility Requirements* B. Aboba, W. Dixon
- RFC 3810**  
*Multicast Listener Discovery Version 2 (MLDv2) for IPv6* R. Vida, Ed., L. Costa, Ed.
- RFC 3947**  
*Negotiation of NAT-Traversal in the IKE* T. Kivinen, B. Swander, A. Huttunen, V. Volpe
- RFC 3948**  
*UDP Encapsulation of IPsec ESP Packets* A. Huttunen, B. Swander, V. Volpe, L. DiBurro, M. Stenberg
- RFC 4001**  
*Textual Conventions for Internet Network Addresses* M. Daniele, B. Haberman, S. Routhier, J. Schoenwaelder
- RFC 4007**  
*IPv6 Scoped Address Architecture* S. Deering, B. Haberman, T. Jinmei, E. Nordmark, B. Zill
- RFC 4022**  
*Management Information Base for the Transmission Control Protocol (TCP)* R. Raghunathan
- RFC 4106**  
*The Use of Galois/Counter Mode (GCM) in IPsec Encapsulating Security Payload (ESP)* J. Viega, D. McGrew
- RFC 4109**  
*Algorithms for Internet Key Exchange version 1 (IKEv1)* P. Hoffman

- RFC 4113**  
*Management Information Base for the User Datagram Protocol (UDP)* B. Fenner,  
J. Flick
- RFC 4191**  
*Default Router Preferences and More-Specific Routes* R. Draves, D. Thaler
- RFC 4217**  
*Securing FTP with TLS* P. Ford-Hutchinson
- RFC 4292**  
*IP Forwarding Table MIB* B. Haberman
- RFC 4293**  
*Management Information Base for the Internet Protocol (IP)* S. Routhier
- RFC 4301**  
*Security Architecture for the Internet Protocol* S. Kent, K. Seo
- RFC 4302**  
*IP Authentication Header* S. Kent
- RFC 4303**  
*IP Encapsulating Security Payload (ESP)* S. Kent
- RFC 4304**  
*Extended Sequence Number (ESN) Addendum to IPsec Domain of Interpretation (DOI) for Internet Security Association and Key Management Protocol (ISAKMP)* S. Kent
- RFC 4307**  
*Cryptographic Algorithms for Use in the Internet Key Exchange Version 2 (IKEv2)* J. Schiller
- RFC 4308**  
*Cryptographic Suites for IPsec* P. Hoffman
- RFC 4434**  
*The AES-XCBC-PRF-128 Algorithm for the Internet Key Exchange Protocol* P. Hoffman
- RFC 4443**  
*Internet Control Message Protocol (ICMPv6) for the Internet Protocol Version 6 (IPv6) Specification* A. Conta, S. Deering
- RFC 4552**  
*Authentication/Confidentiality for OSPFv3* M. Gupta, N. Melam
- RFC 4678**  
*Server/Application State Protocol v1* A. Bivens
- RFC 4753**  
*ECP Groups for IKE and IKEv2* D. Fu, J. Solinas
- RFC 4754**  
*IKE and IKEv2 Authentication Using the Elliptic Curve Digital Signature Algorithm (ECDSA)* D. Fu, J. Solinas
- RFC 4809**  
*Requirements for an IPsec Certificate Management Profile* C. Bonatti, Ed., S. Turner, Ed., G. Lebovitz, Ed.
- RFC 4835**  
*Cryptographic Algorithm Implementation Requirements for Encapsulating Security Payload (ESP) and Authentication Header (AH)* V. Manral

- RFC 4862**  
*IPv6 Stateless Address Autoconfiguration* S. Thomson, T. Narten, T. Jinmei
- RFC 4868**  
*Using HMAC-SHA-256, HMAC-SHA-384, and HMAC-SHA-512 with IPsec* S. Kelly, S. Frankel
- RFC 4869**  
*Suite B Cryptographic Suites for IPsec* L. Law, J. Solinas
- RFC 4941**  
*Privacy Extensions for Stateless Address Autoconfiguration in IPv6* T. Narten, R. Draves, S. Krishnan
- RFC 4945**  
*The Internet IP Security PKI Profile of IKEv1/ISAKMP, IKEv2, and PKIX* B. Korver
- RFC 5014**  
*IPv6 Socket API for Source Address Selection* E. Nordmark, S. Chakrabarti, J. Laganier
- RFC 5095**  
*Deprecation of Type 0 Routing Headers in IPv6* J. Abley, P. Savola, G. Neville-Neil
- RFC 5175**  
*IPv6 Router Advertisement Flags Option* B. Haberman, Ed., R. Hinden
- RFC 5282**  
*Using Authenticated Encryption Algorithms with the Encrypted Payload of the Internet Key Exchange version 2 (IKEv2) Protocol* D. Black, D. McGrew
- RFC 5996**  
*Internet Key Exchange Protocol Version 2 (IKEv2)* C. Kaufman, P. Hoffman, Y. Nir, P. Eronen

## **Internet drafts**

Internet drafts are working documents of the Internet Engineering Task Force (IETF), its areas, and its working groups. Other groups can also distribute working documents as Internet drafts. You can see Internet drafts at <http://www.ietf.org/ID.html>.



---

## Appendix D. Architectural specifications

This appendix lists documents that provide architectural specifications for the SNA Protocol.

The APPN Implementers' Workshop (AIW) architecture documentation includes the following architectural specifications for SNA APPN and HPR:

- APPN Architecture Reference (SG30-3422-04)
- APPN Branch Extender Architecture Reference Version 1.1
- APPN Dependent LU Requester Architecture Reference Version 1.5
- APPN Extended Border Node Architecture Reference Version 1.0
- APPN High Performance Routing Architecture Reference Version 4.0
- SNA Formats (GA27-3136-20)
- SNA Technical Overview (GC30-3073-04)

For more information, see the AIW documentation page at <http://www.ibm.com/support/docview.wss?rs=852&uid=swg27017843>.

The following RFC also contains SNA architectural specifications:

- RFC 2353 *APPN/HPR in IP Networks APPN Implementers' Workshop Closed Pages Document*

RFCs can be obtained from:

Government Systems, Inc.  
Attn: Network Information Center  
14200 Park Meadow Drive  
Suite 200  
Chantilly, VA 22021

Many RFCs are available online. Hardcopies of all RFCs are available from the NIC, either individually or by subscription. Online copies are available using FTP from the NIC at <http://www.rfc-editor.org/rfc.html>.

Use FTP to download the files, using the following format:

```
RFC:RFC-INDEX.TXT  
RFC:RFCnnnn.TXT  
RFC:RFCnnnn.PS
```

where:

- *nnnn* is the RFC number.
- TXT is the text format.
- PS is the postscript format.

You can also request RFCs through electronic mail, from the automated NIC mail server, by sending a message to [service@nic.ddn.mil](mailto:service@nic.ddn.mil) with a subject line of RFC *nnnn* for text versions or a subject line of RFC *nnnn*.PS for PostScript versions. To request a copy of the RFC index, send a message with a subject line of RFC INDEX.

For more information, contact [nic@nic.ddn.mil](mailto:nic@nic.ddn.mil).



---

## Appendix E. Accessibility

Publications for this product are offered in Adobe Portable Document Format (PDF) and should be compliant with accessibility standards. If you experience difficulties when using PDF files, you can view the information through the z/OS Internet Library website or the z/OS Information Center. If you continue to experience problems, send an email to [mhvrcfs@us.ibm.com](mailto:mhvrcfs@us.ibm.com) or write to:

IBM Corporation  
Attention: MHVRCFS Reader Comments  
Department H6MA, Building 707  
2455 South Road  
Poughkeepsie, NY 12601-5400  
USA

Accessibility features help a user who has a physical disability, such as restricted mobility or limited vision, to use software products successfully. The major accessibility features in z/OS enable users to:

- Use assistive technologies such as screen readers and screen magnifier software
- Operate specific or equivalent features using only the keyboard
- Customize display attributes such as color, contrast, and font size

### Using assistive technologies

Assistive technology products, such as screen readers, function with the user interfaces found in z/OS. Consult the assistive technology documentation for specific information when using such products to access z/OS interfaces.

### Keyboard navigation of the user interface

Users can access z/OS user interfaces using TSO/E or ISPF. See *z/OS TSO/E Primer*, *z/OS TSO/E User's Guide*, and *z/OS ISPF User's Guide Vol I* for information about accessing TSO/E and ISPF interfaces. These guides describe how to use TSO/E and ISPF, including the use of keyboard shortcuts or function keys (PF keys). Each guide includes the default settings for the PF keys and explains how to modify their functions.

### z/OS information

z/OS information is accessible using screen readers with the BookServer or Library Server versions of z/OS books in the Internet library at [www.ibm.com/systems/z/os/zos/bkserv/](http://www.ibm.com/systems/z/os/zos/bkserv/).

One exception is command syntax that is published in railroad track format, which is accessible using screen readers with the Information Center, as described in "Dotted decimal syntax diagrams."

### Dotted decimal syntax diagrams

Syntax diagrams are provided in dotted decimal format for users accessing the Information Center using a screen reader. In dotted decimal format, each syntax element is written on a separate line. If two or more syntax elements are always

present together (or always absent together), they can appear on the same line, because they can be considered as a single compound syntax element.

Each line starts with a dotted decimal number; for example, 3 or 3.1 or 3.1.1. To hear these numbers correctly, make sure that your screen reader is set to read out punctuation. All the syntax elements that have the same dotted decimal number (for example, all the syntax elements that have the number 3.1) are mutually exclusive alternatives. If you hear the lines 3.1 USERID and 3.1 SYSTEMID, you know that your syntax can include either USERID or SYSTEMID, but not both.

The dotted decimal numbering level denotes the level of nesting. For example, if a syntax element with dotted decimal number 3 is followed by a series of syntax elements with dotted decimal number 3.1, all the syntax elements numbered 3.1 are subordinate to the syntax element numbered 3.

Certain words and symbols are used next to the dotted decimal numbers to add information about the syntax elements. Occasionally, these words and symbols might occur at the beginning of the element itself. For ease of identification, if the word or symbol is a part of the syntax element, it is preceded by the backslash (\) character. The \* symbol can be used next to a dotted decimal number to indicate that the syntax element repeats. For example, syntax element \*FILE with dotted decimal number 3 is given the format 3 \\* FILE. Format 3\* FILE indicates that syntax element FILE repeats. Format 3\* \\* FILE indicates that syntax element \* FILE repeats.

Characters such as commas, which are used to separate a string of syntax elements, are shown in the syntax just before the items they separate. These characters can appear on the same line as each item, or on a separate line with the same dotted decimal number as the relevant items. The line can also show another symbol giving information about the syntax elements. For example, the lines 5.1\*, 5.1 LASTRUN, and 5.1 DELETE mean that if you use more than one of the LASTRUN and DELETE syntax elements, the elements must be separated by a comma. If no separator is given, assume that you use a blank to separate each syntax element.

If a syntax element is preceded by the % symbol, this indicates a reference that is defined elsewhere. The string following the % symbol is the name of a syntax fragment rather than a literal. For example, the line 2.1 %OP1 means that you should see separate syntax fragment OP1.

The following words and symbols are used next to the dotted decimal numbers:

- A question mark (?) means an optional syntax element. A dotted decimal number followed by the ? symbol indicates that all the syntax elements with a corresponding dotted decimal number, and any subordinate syntax elements, are optional. If there is only one syntax element with a dotted decimal number, the ? symbol is displayed on the same line as the syntax element, (for example 5? NOTIFY). If there is more than one syntax element with a dotted decimal number, the ? symbol is displayed on a line by itself, followed by the syntax elements that are optional. For example, if you hear the lines 5 ?, 5 NOTIFY, and 5 UPDATE, you know that syntax elements NOTIFY and UPDATE are optional; that is, you can choose one or none of them. The ? symbol is equivalent to a bypass line in a railroad diagram.
- An exclamation mark (!) means a default syntax element. A dotted decimal number followed by the ! symbol and a syntax element indicate that the syntax element is the default option for all syntax elements that share the same dotted

decimal number. Only one of the syntax elements that share the same dotted decimal number can specify a ! symbol. For example, if you hear the lines 2? FILE, 2.1! (KEEP), and 2.1 (DELETE), you know that (KEEP) is the default option for the FILE keyword. In this example, if you include the FILE keyword but do not specify an option, default option KEEP will be applied. A default option also applies to the next higher dotted decimal number. In this example, if the FILE keyword is omitted, default FILE(KEEP) is used. However, if you hear the lines 2? FILE, 2.1, 2.1.1! (KEEP), and 2.1.1 (DELETE), the default option KEEP applies only to the next higher dotted decimal number, 2.1 (which does not have an associated keyword), and does not apply to 2? FILE. Nothing is used if the keyword FILE is omitted.

- An asterisk (\*) means a syntax element that can be repeated 0 or more times. A dotted decimal number followed by the \* symbol indicates that this syntax element can be used zero or more times; that is, it is optional and can be repeated. For example, if you hear the line 5.1\* data area, you know that you can include one data area, more than one data area, or no data area. If you hear the lines 3\*, 3 HOST, and 3 STATE, you know that you can include HOST, STATE, both together, or nothing.

**Notes:**

1. If a dotted decimal number has an asterisk (\*) next to it and there is only one item with that dotted decimal number, you can repeat that same item more than once.
  2. If a dotted decimal number has an asterisk next to it and several items have that dotted decimal number, you can use more than one item from the list, but you cannot use the items more than once each. In the previous example, you could write HOST STATE, but you could not write HOST HOST.
  3. The \* symbol is equivalent to a loop-back line in a railroad syntax diagram.
- + means a syntax element that must be included one or more times. A dotted decimal number followed by the + symbol indicates that this syntax element must be included one or more times; that is, it must be included at least once and can be repeated. For example, if you hear the line 6.1+ data area, you must include at least one data area. If you hear the lines 2+, 2 HOST, and 2 STATE, you know that you must include HOST, STATE, or both. Similar to the \* symbol, the + symbol can only repeat a particular item if it is the only item with that dotted decimal number. The + symbol, like the \* symbol, is equivalent to a loop-back line in a railroad syntax diagram.



---

## Notices

This information was developed for products and services offered in the USA.

IBM may not offer all of the products, services, or features discussed in this document in other countries. Consult your local IBM representative for information on the products and services currently available in your area. Any reference to an IBM product, program, or service is not intended to state or imply that only that IBM product, program, or service may be used. Any functionally equivalent product, program, or service that does not infringe any IBM intellectual property right may be used instead. However, it is the user's responsibility to evaluate and verify the operation of any non-IBM product, program, or service.

IBM may have patents or pending patent applications covering subject matter described in this document. The furnishing of this document does not give you any license to these patents. You can send license inquiries, in writing, to:

IBM Director of Licensing  
IBM Corporation  
North Castle Drive  
Armonk, NY 10504-1785  
U.S.A.

For license inquiries regarding double-byte (DBCS) information, contact the IBM Intellectual Property Department in your country or send inquiries, in writing, to:

Intellectual Property Licensing  
Legal and Intellectual Property Law  
IBM Japan, Ltd.  
19-21, Nihonbashi-Hakozakicho, Chuo-ku  
Tokyo 103-8510, Japan

The following paragraph does not apply to the United Kingdom or any other country where such provisions are inconsistent with local law: INTERNATIONAL BUSINESS MACHINES CORPORATION PROVIDES THIS PUBLICATION "AS IS" WITHOUT WARRANTY OF ANY KIND, EITHER EXPRESS OR IMPLIED, INCLUDING, BUT NOT LIMITED TO, THE IMPLIED WARRANTIES OF NON-INFRINGEMENT, MERCHANTABILITY OR FITNESS FOR A PARTICULAR PURPOSE. Some states do not allow disclaimer of express or implied warranties in certain transactions, therefore, this statement may not apply to you.

This information could include technical inaccuracies or typographical errors. Changes are periodically made to the information herein; these changes will be incorporated in new editions of the publication. IBM may make improvements and/or changes in the product(s) and/or the program(s) described in this publication at any time without notice.

Any references in this information to non-IBM websites are provided for convenience only and do not in any manner serve as an endorsement of those websites. The materials at those websites are not part of the materials for this IBM product and use of those websites is at your own risk.

IBM may use or distribute any of the information you supply in any way it believes appropriate without incurring any obligation to you.

Licensees of this program who want to have information about it for the purpose of enabling: (i) the exchange of information between independently created programs and other programs (including this one) and (ii) the mutual use of the information which has been exchanged, should contact:

Site Counsel  
IBM Corporation  
P.O. Box 12195  
3039 Cornwallis Road  
Research Triangle Park, North Carolina 27709-2195  
U.S.A

Such information may be available, subject to appropriate terms and conditions, including in some cases, payment of a fee.

The licensed program described in this information and all licensed material available for it are provided by IBM under terms of the IBM Customer Agreement, IBM International Program License Agreement, or any equivalent agreement between us.

Any performance data contained herein was determined in a controlled environment. Therefore, the results obtained in other operating environments may vary significantly. Some measurements may have been made on development-level systems and there is no guarantee that these measurements will be the same on generally available systems. Furthermore, some measurement may have been estimated through extrapolation. Actual results may vary. Users of this document should verify the applicable data for their specific environment.

Information concerning non-IBM products was obtained from the suppliers of those products, their published announcements or other publicly available sources. IBM has not tested those products and cannot confirm the accuracy of performance, compatibility or any other claims related to non-IBM products. Questions on the capabilities of non-IBM products should be addressed to the suppliers of those products.

All statements regarding IBM's future direction or intent are subject to change or withdrawal without notice, and represent goals and objectives only.

This information contains examples of data and reports used in daily business operations. To illustrate them as completely as possible, the examples include the names of individuals, companies, brands, and products. All of these names are fictitious and any similarity to the names and addresses used by an actual business enterprise is entirely coincidental.

If you are viewing this information softcopy, the photographs and color illustrations might not appear.

#### COPYRIGHT LICENSE:

This information might contain sample application programs in source language, which illustrates programming techniques on various operating platforms. You may copy, modify, and distribute these sample programs in any form without payment to IBM, for the purposes of developing, using, marketing or distributing



application programs conforming to the application programming interface for the operating platform for which the sample programs are written. These examples have not been thoroughly tested under all conditions. IBM, therefore, cannot guarantee or imply reliability, serviceability, or function of these programs. The sample programs are provided "AS IS", without warranty of any kind. IBM shall not be liable for any damages arising out of your use of the sample programs.

Each copy or any portion of these sample programs or any derivative work must include a copyright notice as follows:

© (your company name) (year). Portions of this code are derived from IBM Corp. Sample Programs. © Copyright IBM Corp. \_enter the year or years\_.

IBM is required to include the following statements in order to distribute portions of this document and the software described herein to which contributions have been made by The University of California. Portions herein © Copyright 1979, 1980, 1983, 1986, Regents of the University of California. Reproduced by permission. Portions herein were developed at the Electrical Engineering and Computer Sciences Department at the Berkeley campus of the University of California under the auspices of the Regents of the University of California.

Portions of this publication relating to RPC are Copyright © Sun Microsystems, Inc., 1988, 1989.

Some portions of this publication relating to X Window System\*\* are Copyright © 1987, 1988 by Digital Equipment Corporation, Maynard, Massachusetts, and the Massachusetts Institute Of Technology, Cambridge, Massachusetts.

Some portions of this publication relating to X Window System are Copyright © 1986, 1987, 1988 by Hewlett-Packard Corporation.

Permission to use, copy, modify, and distribute the M.I.T., Digital Equipment Corporation, and Hewlett-Packard Corporation portions of this software and its documentation for any purpose without fee is hereby granted, provided that the above copyright notice appears in all copies and that both that copyright notice and this permission notice appear in supporting documentation, and that the names of M.I.T., Digital, and Hewlett-Packard not be used in advertising or publicity pertaining to distribution of the software without specific, written prior permission. M.I.T., Digital, and Hewlett-Packard make no representation about the suitability of this software for any purpose. It is provided "as is" without express or implied warranty.

Copyright © 1983, 1995-1997 Eric P. Allman

Copyright © 1988, 1993 The Regents of the University of California.

Redistribution and use in source and binary forms, with or without modification, are permitted provided that the following conditions are met:

1. Redistributions of source code must retain the above copyright notice, this list of conditions and the following disclaimer.
2. Redistributions in binary form must reproduce the above copyright notice, this list of conditions and the following disclaimer in the documentation and/or other materials provided with the distribution.
3. All advertising materials mentioning features or use of this software must display the following acknowledgment:

This product includes software developed by the University of California, Berkeley and its contributors.

4. Neither the name of the University nor the names of its contributors may be used to endorse or promote products derived from this software without specific prior written permission.

THIS SOFTWARE IS PROVIDED BY THE REGENTS AND CONTRIBUTORS "AS IS" AND ANY EXPRESS OR IMPLIED WARRANTIES, INCLUDING, BUT NOT LIMITED TO, THE IMPLIED WARRANTIES OF MERCHANTABILITY AND FITNESS FOR A PARTICULAR PURPOSE ARE DISCLAIMED. IN NO EVENT SHALL THE REGENTS OR CONTRIBUTORS BE LIABLE FOR ANY DIRECT, INDIRECT, INCIDENTAL, SPECIAL, EXEMPLARY, OR CONSEQUENTIAL DAMAGES (INCLUDING, BUT NOT LIMITED TO, PROCUREMENT OF SUBSTITUTE GOODS OR SERVICES; LOSS OF USE, DATA, OR PROFITS; OR BUSINESS INTERRUPTION) HOWEVER CAUSED AND ON ANY THEORY OF LIABILITY, WHETHER IN CONTRACT, STRICT LIABILITY, OR TORT (INCLUDING NEGLIGENCE OR OTHERWISE) ARISING IN ANY WAY OUT OF THE USE OF THIS SOFTWARE, EVEN IF ADVISED OF THE POSSIBILITY OF SUCH DAMAGE.

This software program contains code, and/or derivatives or modifications of code originating from the software program "Popper." Popper is Copyright ©1989-1991 The Regents of the University of California. Popper was created by Austin Shelton, Information Systems and Technology, University of California, Berkeley.

Permission from the Regents of the University of California to use, copy, modify, and distribute the "Popper" software contained herein for any purpose, without fee, and without a written agreement is hereby granted, provided that the above copyright notice and this paragraph and the following two paragraphs appear in all copies. HOWEVER, ADDITIONAL PERMISSIONS MAY BE NECESSARY FROM OTHER PERSONS OR ENTITIES, TO USE DERIVATIVES OR MODIFICATIONS OF POPPER.

IN NO EVENT SHALL THE UNIVERSITY OF CALIFORNIA BE LIABLE TO ANY PARTY FOR DIRECT, INDIRECT, SPECIAL, INCIDENTAL, OR CONSEQUENTIAL DAMAGES, INCLUDING LOST PROFITS, ARISING OUT OF THE USE OF THE POPPER SOFTWARE, OR ITS DERIVATIVES OR MODIFICATIONS, AND ITS DOCUMENTATION, EVEN IF THE UNIVERSITY OF CALIFORNIA HAS BEEN ADVISED OF THE POSSIBILITY OF SUCH DAMAGE.

THE UNIVERSITY OF CALIFORNIA SPECIFICALLY DISCLAIMS ANY WARRANTIES, INCLUDING, BUT NOT LIMITED TO, THE IMPLIED WARRANTIES OF MERCHANTABILITY AND FITNESS FOR A PARTICULAR PURPOSE. THE POPPER SOFTWARE PROVIDED HEREUNDER IS ON AN "AS IS" BASIS, AND THE UNIVERSITY OF CALIFORNIA HAS NO OBLIGATIONS TO PROVIDE MAINTENANCE, SUPPORT, UPDATES, ENHANCEMENTS, OR MODIFICATIONS.

Copyright © 1983 The Regents of the University of California.

Redistribution and use in source and binary forms are permitted provided that the above copyright notice and this paragraph are duplicated in all such forms and that any documentation, advertising materials, and other materials related to such distribution and use acknowledge that the software was developed by the University of California, Berkeley. The name of the University may not be used to endorse or promote products derived from this software without specific prior

written permission. THIS SOFTWARE IS PROVIDED ``AS IS" AND WITHOUT ANY EXPRESS OR IMPLIED WARRANTIES, INCLUDING, WITHOUT LIMITATION, THE IMPLIED WARRANTIES OF MERCHANTABILITY AND FITNESS FOR A PARTICULAR PURPOSE.

Copyright © 1991, 1993 The Regents of the University of California.

Redistribution and use in source and binary forms, with or without modification, are permitted provided that the following conditions are met:

1. Redistributions of source code must retain the above copyright notice, this list of conditions and the following disclaimer.
2. Redistributions in binary form must reproduce the above copyright notice, this list of conditions and the following disclaimer in the documentation and/or other materials provided with the distribution.
3. All advertising materials mentioning features or use of this software must display the following acknowledgment:  
This product includes software developed by the University of California, Berkeley and its contributors.
4. Neither the name of the University nor the names of its contributors may be used to endorse or promote products derived from this software without specific prior written permission.

THIS SOFTWARE IS PROVIDED BY THE REGENTS AND CONTRIBUTORS ``AS IS" AND ANY EXPRESS OR IMPLIED WARRANTIES, INCLUDING, BUT NOT LIMITED TO, THE IMPLIED WARRANTIES OF MERCHANTABILITY AND FITNESS FOR A PARTICULAR PURPOSE ARE DISCLAIMED. IN NO EVENT SHALL THE REGENTS OR CONTRIBUTORS BE LIABLE FOR ANY DIRECT, INDIRECT, INCIDENTAL, SPECIAL, EXEMPLARY, OR CONSEQUENTIAL DAMAGES (INCLUDING, BUT NOT LIMITED TO, PROCUREMENT OF SUBSTITUTE GOODS OR SERVICES; LOSS OF USE, DATA, OR PROFITS; OR BUSINESS INTERRUPTION) HOWEVER CAUSED AND ON ANY THEORY OF LIABILITY, WHETHER IN CONTRACT, STRICT LIABILITY, OR TORT (INCLUDING NEGLIGENCE OR OTHERWISE) ARISING IN ANY WAY OUT OF THE USE OF THIS SOFTWARE, EVEN IF ADVISED OF THE POSSIBILITY OF SUCH DAMAGE.

Copyright © 1990 by the Massachusetts Institute of Technology

Export of this software from the United States of America may require a specific license from the United States Government. It is the responsibility of any person or organization contemplating export to obtain such a license before exporting.

WITHIN THAT CONSTRAINT, permission to use, copy, modify, and distribute this software and its documentation for any purpose and without fee is hereby granted, provided that the above copyright notice appear in all copies and that both that copyright notice and this permission notice appear in supporting documentation, and that the name of M.I.T. not be used in advertising or publicity pertaining to distribution of the software without specific, written prior permission. Furthermore if you modify this software you must label your software as modified software and not distribute it in such a fashion that it might be confused with the original M.I.T. software. M.I.T. makes no representations about the suitability of this software for any purpose. It is provided "as is" without express or implied warranty.

Copyright © 1998 by the FundsXpress, INC.

Export of this software from the United States of America may require a specific license from the United States Government. It is the responsibility of any person or organization contemplating export to obtain such a license before exporting.

WITHIN THAT CONSTRAINT, permission to use, copy, modify, and distribute this software and its documentation for any purpose and without fee is hereby granted, provided that the above copyright notice appear in all copies and that both that copyright notice and this permission notice appear in supporting documentation, and that the name of FundsXpress not be used in advertising or publicity pertaining to distribution of the software without specific, written prior permission. FundsXpress makes no representations about the suitability of this software for any purpose. It is provided "as is" without express or implied warranty.

THIS SOFTWARE IS PROVIDED ``AS IS" AND WITHOUT ANY EXPRESS OR IMPLIED WARRANTIES, INCLUDING, WITHOUT LIMITATION, THE IMPLIED WARRANTIES OF MERCHANTABILITY AND FITNESS FOR A PARTICULAR PURPOSE.

Copyright © 1999, 2000 Internet Software Consortium.

Permission to use, copy, modify, and distribute this software for any purpose with or without fee is hereby granted, provided that the above copyright notice and this permission notice appear in all copies.

THE SOFTWARE IS PROVIDED "AS IS" AND INTERNET SOFTWARE CONSORTIUM DISCLAIMS ALL WARRANTIES WITH REGARD TO THIS SOFTWARE INCLUDING ALL IMPLIED WARRANTIES OF MERCHANTABILITY AND FITNESS. IN NO EVENT SHALL INTERNET SOFTWARE CONSORTIUM BE LIABLE FOR ANY SPECIAL, DIRECT, INDIRECT, OR CONSEQUENTIAL DAMAGES OR ANY DAMAGES WHATSOEVER RESULTING FROM LOSS OF USE, DATA OR PROFITS, WHETHER IN AN ACTION OF CONTRACT, NEGLIGENCE OR OTHER TORTIOUS ACTION, ARISING OUT OF OR IN CONNECTION WITH THE USE OR PERFORMANCE OF THIS SOFTWARE.

Copyright © 1995-1998 Eric Young (eay@cryptsoft.com)

This package is an SSL implementation written by Eric Young (eay@cryptsoft.com). The implementation was written so as to conform with Netscape's SSL.

This library is free for commercial and non-commercial use as long as the following conditions are adhered to. The following conditions apply to all code found in this distribution, be it the RC4, RSA, lhash, DES, etc., code; not just the SSL code. The SSL documentation included with this distribution is covered by the same copyright terms except that the holder is Tim Hudson (tjh@cryptsoft.com).

Copyright remains Eric Young's, and as such any Copyright notices in the code are not to be removed. If this package is used in a product, Eric Young should be given attribution as the author of the parts of the library used. This can be in the form of a textual message at program startup or in documentation (online or textual) provided with the package.

Redistribution and use in source and binary forms, with or without modification, are permitted provided that the following conditions are met:

1. Redistributions of source code must retain the copyright notice, this list of conditions and the following disclaimer.

2. Redistributions in binary form must reproduce the above copyright notice, this list of conditions and the following disclaimer in the documentation and/or other materials provided with the distribution.
3. All advertising materials mentioning features or use of this software must display the following acknowledgment: "This product includes cryptographic software written by Eric Young (eay@cryptsoft.com)". The word 'cryptographic' can be left out if the routines from the library being used are not cryptographic related.
4. If you include any Windows specific code (or a derivative thereof) from the apps directory (application code) you must include acknowledgment:  
"This product includes software written by Tim Hudson (tjh@cryptsoft.com)"

THIS SOFTWARE IS PROVIDED BY ERIC YOUNG ``AS IS" AND ANY EXPRESS OR IMPLIED WARRANTIES, INCLUDING, BUT NOT LIMITED TO, THE IMPLIED WARRANTIES OF MERCHANTABILITY AND FITNESS FOR A PARTICULAR PURPOSE ARE DISCLAIMED. IN NO EVENT SHALL THE AUTHOR OR CONTRIBUTORS BE LIABLE FOR ANY DIRECT, INDIRECT, INCIDENTAL, SPECIAL, EXEMPLARY, OR CONSEQUENTIAL DAMAGES (INCLUDING, BUT NOT LIMITED TO, PROCUREMENT OF SUBSTITUTE GOODS OR SERVICES; LOSS OF USE, DATA, OR PROFITS; OR BUSINESS INTERRUPTION) HOWEVER CAUSED AND ON ANY THEORY OF LIABILITY, WHETHER IN CONTRACT, STRICT LIABILITY, OR TORT (INCLUDING NEGLIGENCE OR OTHERWISE) ARISING IN ANY WAY OUT OF THE USE OF THIS SOFTWARE, EVEN IF ADVISED OF THE POSSIBILITY OF SUCH DAMAGE.

The license and distribution terms for any publicly available version or derivative of this code cannot be changed. i.e. this code cannot simply be copied and put under another distribution license [including the GNU Public License.]

This product includes cryptographic software written by Eric Young.

Copyright © 1999, 2000 Internet Software Consortium.

Permission to use, copy, modify, and distribute this software for any purpose with or without fee is hereby granted, provided that the above copyright notice and this permission notice appear in all copies.

THE SOFTWARE IS PROVIDED "AS IS" AND INTERNET SOFTWARE CONSORTIUM DISCLAIMS ALL WARRANTIES WITH REGARD TO THIS SOFTWARE INCLUDING ALL IMPLIED WARRANTIES OF MERCHANTABILITY AND FITNESS. IN NO EVENT SHALL INTERNET SOFTWARE CONSORTIUM BE LIABLE FOR ANY SPECIAL, DIRECT, INDIRECT, OR CONSEQUENTIAL DAMAGES OR ANY DAMAGES WHATSOEVER RESULTING FROM LOSS OF USE, DATA OR PROFITS, WHETHER IN AN ACTION OF CONTRACT, NEGLIGENCE OR OTHER TORTIOUS ACTION, ARISING OUT OF OR IN CONNECTION WITH THE USE OR PERFORMANCE OF THIS SOFTWARE.

Copyright © 2004 IBM Corporation and its licensors, including Sendmail, Inc., and the Regents of the University of California.

Copyright © 1999,2000,2001 Compaq Computer Corporation

Copyright © 1999,2000,2001 Hewlett-Packard Company

Copyright © 1999,2000,2001 IBM Corporation

Copyright © 1999,2000,2001 Hummingbird Communications Ltd.

Copyright © 1999,2000,2001 Silicon Graphics, Inc.

Copyright © 1999,2000,2001 Sun Microsystems, Inc.

Copyright © 1999,2000,2001 The Open Group

Permission is hereby granted, free of charge, to any person obtaining a copy of this software and associated documentation files (the "Software"), to deal in the Software without restriction, including without limitation the rights to use, copy, modify, merge, publish, distribute, and/or sell copies of the Software, and to permit persons to whom the Software is furnished to do so, provided that the above copyright notice(s) and this permission notice appear in all copies of the Software and that both the above copyright notice(s) and this permission notice appear in supporting documentation.

THE SOFTWARE IS PROVIDED "AS IS", WITHOUT WARRANTY OF ANY KIND, EXPRESS OR IMPLIED, INCLUDING BUT NOT LIMITED TO THE WARRANTIES OF MERCHANTABILITY, FITNESS FOR A PARTICULAR PURPOSE AND NONINFRINGEMENT OF THIRD PARTY RIGHTS. IN NO EVENT SHALL THE COPYRIGHT HOLDER OR HOLDERS INCLUDED IN THIS NOTICE BE LIABLE FOR ANY CLAIM, OR ANY SPECIAL INDIRECT OR CONSEQUENTIAL DAMAGES, OR ANY DAMAGES WHATSOEVER RESULTING FROM LOSS OF USE, DATA OR PROFITS, WHETHER IN AN ACTION OF CONTRACT, NEGLIGENCE OR OTHER TORTIOUS ACTION, ARISING OUT OF OR IN CONNECTION WITH THE USE OR PERFORMANCE OF THIS SOFTWARE.

Except as contained in this notice, the name of a copyright holder shall not be used in advertising or otherwise to promote the sale, use or other dealings in this Software without prior written authorization of the copyright holder.

X Window System is a trademark of The Open Group.

If you are viewing this information softcopy, the photographs and color illustrations may not appear.

You can obtain softcopy from the z/OS Collection (SK3T-4269), which contains BookManager and PDF formats.

### **Minimum supported hardware**

The minimum supported hardware for z/OS releases identified in z/OS announcements can subsequently change when service for particular servers or devices is withdrawn. Likewise, the levels of other software products supported on a particular release of z/OS are subject to the service support lifecycle of those products. Therefore, z/OS and its product publications (for example, panels, samples, messages, and product documentation) can include references to hardware and software that is no longer supported.

- For information about software support lifecycle, see: <http://www-01.ibm.com/software/support/systemsz/lifecycle/>
- For information about currently-supported IBM hardware, contact your IBM representative.

---

## Programming interface information

This publication documents intended Programming Interfaces that allow the customer to write programs to obtain the services of z/OS Communications Server.

---

## Policy for unsupported hardware

Various z/OS elements, such as DFSMS, HCD, JES2, JES3, and MVS, contain code that supports specific hardware servers or devices. In some cases, this device-related element support remains in the product even after the hardware devices pass their announced End of Service date. z/OS may continue to service element code; however, it will not provide service related to unsupported hardware devices. Software problems related to these devices will not be accepted for service, and current service activity will cease if a problem is determined to be associated with out-of-support devices. In such cases, fixes will not be issued.

---

## Trademarks

IBM, the IBM logo, and [ibm.com](http://www.ibm.com)<sup>®</sup> are trademarks or registered trademarks of International Business Machines Corp., registered in many jurisdictions worldwide. Other product and service names might be trademarks of IBM or other companies. A current list of IBM trademarks is available on the web at Copyright and trademark information at [www.ibm.com/legal/copytrade.shtml](http://www.ibm.com/legal/copytrade.shtml).

Intel is a registered trademark of Intel Corporation or its subsidiaries in the United States and other countries.

Java<sup>™</sup> and all Java-based trademarks are trademarks or registered trademarks of Oracle and/or its affiliates.

Linux is a registered trademark of Linus Torvalds in the United States, other countries, or both.

Microsoft, Windows, and Windows NT are trademarks of Microsoft Corporation in the United States, other countries, or both.

Adobe and PostScript are either registered trademarks or trademarks of Adobe Systems Incorporated in the United States, and/or other countries.

UNIX is a registered trademark of The Open Group in the United States and other countries.

Other product and service names might be trademarks of IBM or other companies.





---

## Bibliography

This bibliography contains descriptions of the documents in the z/OS Communications Server library.

z/OS Communications Server documentation is available in the following forms:

- Online at the z/OS Internet Library web page at [www.ibm.com/systems/z/os/zos/bkserv/](http://www.ibm.com/systems/z/os/zos/bkserv/)
- In softcopy on CD-ROM collections. See “Softcopy information” on page xiv.

### **z/OS Communications Server library updates**

An index to z/OS Communications Server book updates is at <http://www.ibm.com/support/docview.wss?uid=swg21178966>. Updates to documents are also available on RETAIN<sup>®</sup> and in information APARs (info APARs). Go to <http://www.ibm.com/software/network/commserver/zos/support> to view information APARs. In addition, Info APARs for z/OS documents are in *z/OS and z/OS.e DOC APAR and PTF ++HOLD Documentation*, which can be found at [http://publibz.boulder.ibm.com/cgi-bin/bookmgr\\_OS390/Shelves/ZDOCAPAR](http://publibz.boulder.ibm.com/cgi-bin/bookmgr_OS390/Shelves/ZDOCAPAR).

### **z/OS Communications Server information**

z/OS Communications Server product information is grouped by task in the following tables.

#### **Planning**

Title	Number	Description
z/OS Communications Server: New Function Summary	GC27-3664	This document is intended to help you plan for new IP or SNA function, whether you are migrating from a previous version or installing z/OS for the first time. It summarizes what is new in the release and identifies the suggested and required modifications needed to use the enhanced functions.
z/OS Communications Server: IPv6 Network and Application Design Guide	SC27-3663	This document is a high-level introduction to IPv6. It describes concepts of z/OS Communications Server's support of IPv6, coexistence with IPv4, and migration issues.

#### **Resource definition, configuration, and tuning**

Title	Number	Description
z/OS Communications Server: IP Configuration Guide	SC27-3650	This document describes the major concepts involved in understanding and configuring an IP network. Familiarity with the z/OS operating system, IP protocols, z/OS UNIX System Services, and IBM Time Sharing Option (TSO) is recommended. Use this document with the z/OS Communications Server: IP Configuration Reference.

Title	Number	Description
z/OS Communications Server: IP Configuration Reference	SC27-3651	This document presents information for people who want to administer and maintain IP. Use this document with the z/OS Communications Server: IP Configuration Guide. The information in this document includes: <ul style="list-style-type: none"> <li>• TCP/IP configuration data sets</li> <li>• Configuration statements</li> <li>• Translation tables</li> <li>• Protocol number and port assignments</li> </ul>
z/OS Communications Server: SNA Network Implementation Guide	SC27-3672	This document presents the major concepts involved in implementing an SNA network. Use this document with the z/OS Communications Server: SNA Resource Definition Reference.
z/OS Communications Server: SNA Resource Definition Reference	SC27-3675	This document describes each SNA definition statement, start option, and macroinstruction for user tables. It also describes NCP definition statements that affect SNA. Use this document with the z/OS Communications Server: SNA Network Implementation Guide.
z/OS Communications Server: SNA Resource Definition Samples	SC27-3676	This document contains sample definitions to help you implement SNA functions in your networks, and includes sample major node definitions.
z/OS Communications Server: IP Network Print Facility	SC27-3658	This document is for systems programmers and network administrators who need to prepare their network to route SNA, JES2, or JES3 printer output to remote printers using TCP/IP Services.

## Operation

Title	Number	Description
z/OS Communications Server: IP User's Guide and Commands	SC27-3662	This document describes how to use TCP/IP applications. It contains requests with which a user can log on to a remote host using Telnet, transfer data sets using FTP, send and receive electronic mail, print on remote printers, and authenticate network users.
z/OS Communications Server: IP System Administrator's Commands	SC27-3661	This document describes the functions and commands helpful in configuring or monitoring your system. It contains system administrator's commands, such as TSO NETSTAT, PING, TRACERTE and their UNIX counterparts. It also includes TSO and MVS commands commonly used during the IP configuration process.
z/OS Communications Server: SNA Operation	SC27-3673	This document serves as a reference for programmers and operators requiring detailed information about specific operator commands.
z/OS Communications Server: Quick Reference	SC27-3665	This document contains essential information about SNA and IP commands.

## Customization

Title	Number	Description
z/OS Communications Server: SNA Customization	SC27-3666	This document enables you to customize SNA, and includes the following information: <ul style="list-style-type: none"> <li>• Communication network management (CNM) routing table</li> <li>• Logon-interpret routine requirements</li> <li>• Logon manager installation-wide exit routine for the CLU search exit</li> <li>• TSO/SNA installation-wide exit routines</li> <li>• SNA installation-wide exit routines</li> </ul>

## Writing application programs

Title	Number	Description
z/OS Communications Server: IP Sockets Application Programming Interface Guide and Reference	SC27-3660	This document describes the syntax and semantics of program source code necessary to write your own application programming interface (API) into TCP/IP. You can use this interface as the communication base for writing your own client or server application. You can also use this document to adapt your existing applications to communicate with each other using sockets over TCP/IP.
z/OS Communications Server: IP CICS Sockets Guide	SC27-3649	This document is for programmers who want to set up, write application programs for, and diagnose problems with the socket interface for CICS® using z/OS TCP/IP.
z/OS Communications Server: IP IMS Sockets Guide	SC27-3653	This document is for programmers who want application programs that use the IMS™ TCP/IP application development services provided by the TCP/IP Services of IBM.
z/OS Communications Server: IP Programmer's Guide and Reference	SC27-3659	This document describes the syntax and semantics of a set of high-level application functions that you can use to program your own applications in a TCP/IP environment. These functions provide support for application facilities, such as user authentication, distributed databases, distributed processing, network management, and device sharing. Familiarity with the z/OS operating system, TCP/IP protocols, and IBM Time Sharing Option (TSO) is recommended.
z/OS Communications Server: SNA Programming	SC27-3674	This document describes how to use SNA macroinstructions to send data to and receive data from (1) a terminal in either the same or a different domain, or (2) another application program in either the same or a different domain.
z/OS Communications Server: SNA Programmer's LU 6.2 Guide	SC27-3669	This document describes how to use the SNA LU 6.2 application programming interface for host application programs. This document applies to programs that use only LU 6.2 sessions or that use LU 6.2 sessions along with other session types. (Only LU 6.2 sessions are covered in this document.)
z/OS Communications Server: SNA Programmer's LU 6.2 Reference	SC27-3670	This document provides reference material for the SNA LU 6.2 programming interface for host application programs.
z/OS Communications Server: CSM Guide	SC27-3647	This document describes how applications use the communications storage manager.

Title	Number	Description
z/OS Communications Server: CMIP Services and Topology Agent Guide	SC27-3646	This document describes the Common Management Information Protocol (CMIP) programming interface for application programmers to use in coding CMIP application programs. The document provides guide and reference information about CMIP services and the SNA topology agent.

## Diagnosis

Title	Number	Description
z/OS Communications Server: IP Diagnosis Guide	GC27-3652	This document explains how to diagnose TCP/IP problems and how to determine whether a specific problem is in the TCP/IP product code. It explains how to gather information for and describe problems to the IBM Software Support Center.
z/OS Communications Server: ACF/TAP Trace Analysis Handbook	GC27-3645	This document explains how to gather the trace data that is collected and stored in the host processor. It also explains how to use the Advanced Communications Function/Trace Analysis Program (ACF/TAP) service aid to produce reports for analyzing the trace data information.
z/OS Communications Server: SNA Diagnosis Vol 1, Techniques and Procedures and z/OS Communications Server: SNA Diagnosis Vol 2, FFST Dumps and the VIT	GC27-3667 GC27-3668	These documents help you identify an SNA problem, classify it, and collect information about it before you call the IBM Support Center. The information collected includes traces, dumps, and other problem documentation.
z/OS Communications Server: SNA Data Areas Volume 1 and z/OS Communications Server: SNA Data Areas Volume 2	GC31-6852 GC31-6853	These documents describe SNA data areas and can be used to read an SNA dump. They are intended for IBM programming service representatives and customer personnel who are diagnosing problems with SNA.

## Messages and codes

Title	Number	Description
z/OS Communications Server: SNA Messages	SC27-3671	This document describes the ELM, IKT, IST, IUT, IVT, and USS messages. Other information in this document includes: <ul style="list-style-type: none"> <li>• Command and RU types in SNA messages</li> <li>• Node and ID types in SNA messages</li> <li>• Supplemental message-related information</li> </ul>
z/OS Communications Server: IP Messages Volume 1 (EZA)	SC27-3654	This volume contains TCP/IP messages beginning with EZA.
z/OS Communications Server: IP Messages Volume 2 (EZB, EZD)	SC27-3655	This volume contains TCP/IP messages beginning with EZB or EZD.
z/OS Communications Server: IP Messages Volume 3 (EZY)	SC27-3656	This volume contains TCP/IP messages beginning with EZY.
z/OS Communications Server: IP Messages Volume 4 (EZZ, SNM)	SC27-3657	This volume contains TCP/IP messages beginning with EZZ and SNM.
z/OS Communications Server: IP and SNA Codes	SC27-3648	This document describes codes and other information that appear in z/OS Communications Server messages.

---

# Index

## A

abnormal termination 19  
accessibility 111  
accessing another user's data 5  
address space identifier (ASID) 3, 10  
API  
    CSM 1  
application design considerations 5  
application programming interface  
    CSM 1  
ASID (address space identifier) 3, 10  
ASSIGN\_BUFFER macroinstruction  
    description 14, 23  
    effect on DISPLAY CSM command 3  
authorization 5

## B

borrowers 5  
buffer list  
    contents 9  
    purpose 9  
buffer ownership 2  
buffer pool tokens 8  
buffer pools  
    sizes 1  
    types 1  
buffer return exit routine 9, 18  
buffer states 10  
buffer types 10  
buffers, sharing 3  
BUFLIST parameter 9  
BUFTYPE parameter 10

## C

CHANGE\_OWNER macroinstruction 11, 29  
changing buffer ownership 29  
CLEAR parameter 12  
clearing data from buffers 12  
codes  
    summary of reason codes 77  
    summary of return codes 77  
commands  
    DISPLAY CSM 2  
    DISPLAY TRL 4  
    MODIFY CSM 3  
Communications Server for z/OS, online information xv  
communications storage manager  
    defining 2  
    initializing 2  
    installing 2  
    starting 2  
    system definition 2  
communications storage manager, see CSM 1  
contraction, CSM buffer pools 18  
COPY\_DATA macroinstruction  
    description 13, 34  
    storage key differences 5  
copying data from a CSM buffer 34

CREATE\_POOL macroinstruction 8, 40  
creating a buffer pool 8  
CSM  
    API 1  
    application programming interface 1  
    data space 2  
    defining 2  
    definition of 1  
    initializing 2  
    installing 2  
    overview 1  
    starting 2  
    system definition 2  
CSM buffer list  
    contents 9  
    purpose 9  
CSM parmlib member 2, 17  
CSM storage usage 4

## D

data handling 5  
data space 6  
data space in CSM 2  
defining storage limits 17  
DELETE\_POOL macroinstruction 13, 46  
design considerations, application 5  
diagnosing CSM problems 4  
disability 111  
DISPLAY CSM command 2  
DISPLAY TRL command 2, 4  
DNS, online information xvii  
documentation 6  
DSECTS  
    IVTBUFL (CSM Buffer List Entry) 81  
    IVTDATSP (CSM Data Space Information) 83  
    IVTSTAT (CSM Resource Status Area) 83  
DUMP\_INFO macroinstruction 49  
dumps 5, 15

## E

ECSA (extended common service area) 6  
EXPBUF parameter 17  
extended common service area (ECSA) 6

## F

FIX\_BUFFER macroinstruction 52  
fixed buffers, guaranteed 10  
FREE\_BUFFER macroinstruction 12, 56  
FREERTN parameter 18  
FREETO parameter 12

## G

GET\_BUFFER macroinstruction  
    description 61  
    original requester 5

GET\_BUFFER macroinstruction (*continued*)  
usage 9  
getting dump information 49  
getting storage 9, 61  
GTF trace facility 4

## H

handling data 5  
high performance data transfer (HPDT)  
changing buffer ownership 12  
description 1  
design considerations 5  
HPDT (high performance data transfer)  
changing buffer ownership 12  
description 1  
design considerations 5

## I

IBM Software Support Center, contacting x  
Information APARs xiii  
INITBUF parameter 17  
interfaces  
definition 2  
macroinstructions 6  
messages 2  
monitoring storage 2  
operator commands 2  
programming (API) 1  
trace records 4  
Internet, finding z/OS information online xv  
IVTBUFL (CSM Buffer List Entry) 81  
IVTCSM macroinstruction, return and reason codes 77  
IVTDATSP (CSM Data Space Information) 83  
IVTPRM00 2, 17  
IVTSTATA (CSM Resource Status Area) 83

## K

key, storage 1, 5  
keyboard 111

## L

license, patent, and copyright information 115

## M

macroinstructions  
ASSIGN\_BUFFER request 14, 23  
CHANGE\_OWNER request 11, 29  
COPY\_DATA request 13, 34  
CREATE\_POOL request 8, 40  
DELETE\_POOL request 13, 46  
DUMP\_INFO request 15, 49  
FIX\_BUFFER request 52  
FREE\_BUFFER request 12, 56  
GET\_BUFFER request 9, 61  
PAGE\_BUFFER request 68  
RESOURCE\_STATS request 16, 73  
summary of types 6  
mainframe  
education xiii  
MINFREE parameter 17

MODIFY\_CSM command 3  
monitoring storage 16

## N

normal termination 19

## O

obtaining storage 9, 61  
original requester 5  
OWNERID 3, 10  
ownership of buffers, changing 29  
ownership, buffer 2

## P

PAGE\_BUFFER macroinstruction 68  
paged buffers, eligible 10  
paged buffers, guaranteed 10  
parmlib member 2, 17  
performance monitor interface 4  
PMI 4  
pool registration 40  
pools, buffer  
sizes 1  
types 1  
prerequisite information xiii

## R

reason codes, summary 77  
registering a buffer pool 8  
registration 40  
registration to use a CSM buffer pool 8  
requester, original 5  
requesting buffer pools 9, 61  
RESOURCE\_STATS macroinstruction  
description 6, 73  
usage 16  
responsibilities of ownership 5, 11  
RETPTOKN parameter 8  
return codes, summary 77  
returning buffers to application 9, 18  
returning buffers to CSM 12, 56  
RFC (request for comments) 85  
accessing online xv

## S

SDUMPX macro 15  
sharing buffers 3, 14, 23  
shortcut keys 111  
SNA protocol specifications 109  
softcopy information xiii  
SRCLIST parameter 9  
storage  
constraint 3  
DISPLAY\_CSM command 2  
DISPLAY\_TRL command 4  
MODIFY\_CSM command 4  
monitoring 2  
storage constraint 16  
storage key 1, 5  
storage limits 2

storage limits, defining 17  
storage usage, CSM 4  
storage use, critical 16  
syntax diagram, how to read xi

## T

TARGLIST parameter 9  
task control block 11  
TASKID 11  
TCP/IP  
    online information xv  
    protocol specifications 85  
Technotes xiii  
termination 19  
tokens  
    for buffer pools 8  
    for individual buffers 9  
tracing 4  
trademark information 123  
tuning buffer pools 8

## U

usage 11, 12, 13, 14, 15

## V

VIT 4  
VTAM internal trace 4  
VTAM, online information xv

## Z

z/OS Basic Skills Information Center xiii  
z/OS, documentation library listing 125





---

## Communicating your comments to IBM

If you especially like or dislike anything about this document, use one of the methods listed below to send your comments to IBM. Whichever method you choose, make sure you send your name, address, and telephone number if you would like a reply.

Feel free to comment on specific errors or omissions, accuracy, organization, subject matter, or completeness of this document. However, the comments you send should pertain to only the information in this manual and the way in which the information is presented. To request additional publications, or to ask questions or make comments about the functions of IBM products or systems, you should talk to your IBM representative or to your IBM authorized remarketer.

When you send comments to IBM, you grant IBM a nonexclusive right to use or distribute your comments in any way it believes appropriate without incurring any obligation to you.

Send your comments to us in any of the following ways:

- To send comments by FAX, use this number: 1+919-254-1258
- To send comments electronically, use this address:
  - [comsvrcf@us.ibm.com](mailto:comsvrcf@us.ibm.com)
- To send comments by post, use this address:

International Business Machines Corporation  
Attn: z/OS Communications Server Information Development  
P.O. Box 12195, 3039 Cornwallis Road  
Department AKCA, Building 501  
Research Triangle Park, North Carolina 27709-2195

Make sure to include the following information in your note:

- Title and publication number of this document
- Page number or topic to which your comment applies







Product Number: 5650-ZOS

Printed in USA

SC27-3647-00

