



Power Systems

Managing the control panel functions





Power Systems

Managing the control panel functions

Note

Before using this information and the product it supports, read the information in “Notices,” on page 21, “Safety notices” on page v, the *IBM Systems Safety Notices* manual, G229-9054, and the *IBM Environmental Notices and User Guide*, Z125-5823.

This edition applies to IBM Power Systems™ servers that contain the POWER6® processor and to all associated models.

© Copyright IBM Corporation 2007, 2009.

US Government Users Restricted Rights – Use, duplication or disclosure restricted by GSA ADP Schedule Contract with IBM Corp.

Contents

Safety notices	v
Managing the control panel functions	1
What's new in Managing the control panel functions	1
Control panel concepts	1
Physical control panel	1
Accessing the control panel functions using the physical control panel	3
Putting the physical control panel in manual operating mode	3
Control panel function codes	3
Primary control panel functions	5
Function 01: Display selected IPL type, system operating mode, and IPL speed	5
Function 02: Select IPL type, IPL speed override, system operating mode, and firmware mode	6
Function 03: Restart IPL	8
Function 04: Lamp test	8
Functions 05 - 06: Reserved	8
Function 07: SPCN functions	9
Function 08: Fast power off	10
Functions 09 - 10: Reserved	10
Function 11: SRC display (ASCII string)	10
Function 12: SRC display (hex words 2 - 5)	10
Function 13: SRC display (hex words 6 - 9)	11
Functions 14 - 19: SRC display (callouts)	11
Function 20: System type, model, feature code, and IPL type	12
Customer-extended panel functions	12
Function 21: Service tool initiation	12
Function 22: Partition dump	12
Functions 23 - 24: Reserved	13
Functions 25 - 26: Service switches 1 and 2	13
Functions 27 - 29: Reserved	13
Function 30: Service processor IP address and port location	13
Functions 31 - 33: Reserved	14
Function 34: Retry partition dump	14
Functions 35 - 41: Reserved	14
Function 42: Platform dump	14
Function 43: Service processor dump	14
Functions 44 - 54: Reserved	15
Function 55: View and change platform dump data	15
Functions 56 - 62: Reserved	16
Function 63: Display system status SRCs	16
Function 64: Display diagnostic status SRCs	17
Functions 65 - 70: Not applicable	17
Functions 71 - 99: Reserved	17
Values for IPL types, system operating modes, and speeds	18
Appendix. Notices	21
Trademarks	22
Electronic emission notices	22
Class A Notices	22
Terms and conditions	26

Safety notices

Safety notices may be printed throughout this guide:

- **DANGER** notices call attention to a situation that is potentially lethal or extremely hazardous to people.
- **CAUTION** notices call attention to a situation that is potentially hazardous to people because of some existing condition.
- **Attention** notices call attention to the possibility of damage to a program, device, system, or data.

World Trade safety information

Several countries require the safety information contained in product publications to be presented in their national languages. If this requirement applies to your country, a safety information booklet is included in the publications package shipped with the product. The booklet contains the safety information in your national language with references to the U.S. English source. Before using a U.S. English publication to install, operate, or service this product, you must first become familiar with the related safety information in the booklet. You should also refer to the booklet any time you do not clearly understand any safety information in the U.S. English publications.

German safety information

Das Produkt ist nicht für den Einsatz an Bildschirmarbeitsplätzen im Sinne § 2 der Bildschirmarbeitsverordnung geeignet.

Laser safety information

IBM® servers can use I/O cards or features that are fiber-optic based and that utilize lasers or LEDs.

Laser compliance

All lasers are certified in the U.S. to conform to the requirements of DHHS 21 CFR Subchapter J for class 1 laser products. Outside the U.S., they are certified to be in compliance with IEC 60825 as a class 1 laser product. Consult the label on each part for laser certification numbers and approval information.

CAUTION:

This product might contain one or more of the following devices: CD-ROM drive, DVD-ROM drive, DVD-RAM drive, or laser module, which are Class 1 laser products. Note the following information:

- **Do not remove the covers. Removing the covers of the laser product could result in exposure to hazardous laser radiation. There are no serviceable parts inside the device.**
- **Use of the controls or adjustments or performance of procedures other than those specified herein might result in hazardous radiation exposure.**

(C026)

CAUTION:

Data processing environments can contain equipment transmitting on system links with laser modules that operate at greater than Class 1 power levels. For this reason, never look into the end of an optical fiber cable or open receptacle. (C027)

CAUTION:

This product contains a Class 1M laser. Do not view directly with optical instruments. (C028)

CAUTION:

Some laser products contain an embedded Class 3A or Class 3B laser diode. Note the following information: laser radiation when open. Do not stare into the beam, do not view directly with optical instruments, and avoid direct exposure to the beam. (C030)

Power and cabling information for NEBS (Network Equipment-Building System) GR-1089-CORE

The following comments apply to the IBM servers that have been designated as conforming to NEBS (Network Equipment-Building System) GR-1089-CORE:

The equipment is suitable for installation in the following:

- Network telecommunications facilities
- Locations where the NEC (National Electrical Code) applies

The intrabuilding ports of this equipment are suitable for connection to intrabuilding or unexposed wiring or cabling only. The intrabuilding ports of this equipment *must not* be metallically connected to the interfaces that connect to the OSP (outside plant) or its wiring. These interfaces are designed for use as intrabuilding interfaces only (Type 2 or Type 4 ports as described in GR-1089-CORE) and require isolation from the exposed OSP cabling. The addition of primary protectors is not sufficient protection to connect these interfaces metallically to OSP wiring.

Note: All Ethernet cables must be shielded and grounded at both ends.

The ac-powered system does not require the use of an external surge protection device (SPD).

The dc-powered system employs an isolated DC return (DC-I) design. The DC battery return terminal *shall not* be connected to the chassis or frame ground.

Managing the control panel functions

The control panel functions allow you to interface with the server. Control panel functions range in complexity from functions that display status (such as IPL speed) to service functions that only service representatives must access.

What's new in Managing the control panel functions

Read about new or significantly changed information in Managing the control panel functions since the previous update of this topic collection.

October 2009

Miscellaneous changes have been made throughout the information.

Control panel concepts

Learn about the control panel functions, IPL modes and values, and other concepts.

Physical control panel

The physical control panel is your initial interface with the server. You can use the physical control panel to perform functions such as IPL, power on, and power off.

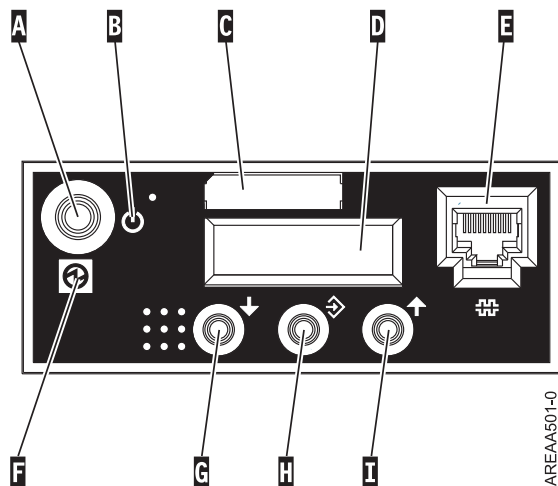

Figure 1. 570 control panel

- **A:** Power-on button
- **B:** On/off power symbol
- **C:** Serial number label
- **D:** Function/Data display
- **E:** System port (S1)
- **F:** Power LED
 - A blinking light indicates standby power to the unit.
 - A constant light indicates full system power to the unit.

Note: There is approximately a 30-second transition period from the time the power-on button is pressed to when the power LED goes from blinking to solid. During the transition period, you might observe the blinking intervals speed up.

- **G:** Decrement button
- **H:** Enter button
- **I:** Increment button

The system attention light is located along the upper right edge of the first drawer.

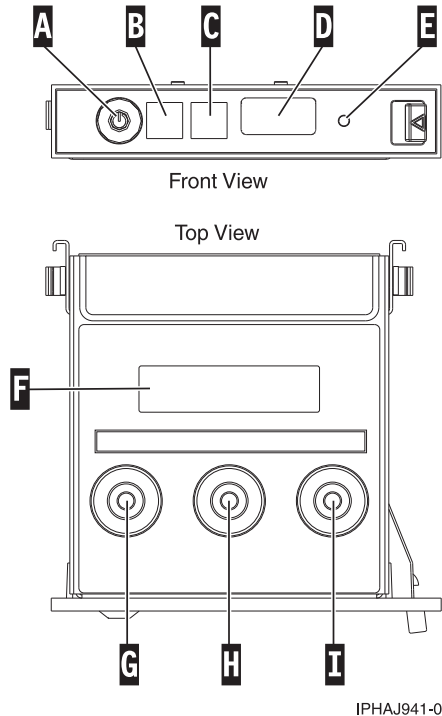

Figure 2. Control panel for the 8203-E4A, 8204-E8A, 9407-M15, 9408-M25, and 9409-M50.

- **A:** Power-on button
- **B:** Power LED
 - A blinking light indicates standby power to the unit.
 - A constant light indicates full system power to the unit.

Note: There is approximately a 30-second transition period from the time the power-on button is pressed to when the power LED goes from blinking to solid. During the transition period, you might observe the blinking intervals speed up.

- **C:** Attention light
- **D:** USB port
- **E:** Pinhole reset button
- **F:** Function/Data display
- **G:** Decrement button
- **H:** Enter button
- **I:** Increment button

Accessing the control panel functions using the physical control panel

The control panel functions correspond to function numbers on the control panel.

To activate a control panel function, do the following:

1. Select a function number by pressing the Increment (↑) or Decrement (↓) button on the control panel.
2. To activate the function, press Enter on the control panel.

Putting the physical control panel in manual operating mode

You must first put the physical control panel in manual operating mode before you can select or activate certain functions.

To put the physical control panel in manual operating mode, do the following:

1. Use the Increment button to scroll to function 02.

```
0 2 _ _ _ _ _ _ _ _ _ _  
_ _ _ _ _ _ _ _ _ _
```

2. Press Enter to start function 02.
3. Press Enter again to move to the second character on the function 02 menu. The current system operating mode is displayed with a pointer, as shown in the following example:

```
0 2 _ _ B _ _ N < _ _ _ _ P _ _ _ _  
_ _ _ _ _ _ _ _ _ _
```

4. Use the Increment button to scroll through the system operating modes, and select M for manual, as shown in the following example:

```
0 2 _ _ B _ _ M < _ _ _ _ P _ _ _ _  
_ _ _ _ _ _ _ _ _ _
```

5. Press Enter to select the system operating mode.
6. Press Enter again to exit function 02.

The control panel is in manual operating mode.

Related reference

“Function 02: Select IPL type, IPL speed override, system operating mode, and firmware mode” on page 6

This function allows you to select the IPL type and logical key mode when the system is either powered on or off.

Control panel function codes

Learn about function codes that are displayed on the control panel to indicate status and function options.

To display all functions, put the control panel in manual operating mode. For details, see Putting the physical control panel in manual operating mode.

The following table includes descriptions of the primary and customer-extended control panel function codes.

Table 1. Primary and customer-extended control panel (32-character) function codes

Function code	Function selected
01	Displays the current IPL parameters. This function is available in both normal and manual operating mode.
02	Used to select the IPL type, system operating mode, IPL speed, and firmware IPL mode. This function is available in both normal and manual operating mode.

Table 1. Primary and customer-extended control panel (32-character) function codes (continued)

Function code	Function selected
03	Restarts an IPL of the system using the selected IPL parameters. This function is available only in manual operating mode and when the system power is on.
04	Performs a lamp test; all displays and indicators are lit. This function is available in both normal and manual operating mode.
05 - 06	Reserved.
07	Allows you to perform SPCN service functions. This function is available only in the manual operating mode and from power on standby.
08	Causes a fast power off. This function is available only when the system is in manual operating mode and the system power is on.
09 - 10	Reserved.
11	Displays a system reference code (SRC) on the control panel using up to 32 ASCII characters, including non-hexadecimal characters. This function is available in both normal and manual operating mode when an SRC is available.
12	Displays an SRC on the control panel using up to four extended SRC data words. This function is available in both normal and manual operating mode when an SRC is available.
13	Displays an SRC on the control panel using up to eight extended SRC data words. This function is available in both normal and manual operating mode when an SRC is available.
14 - 19	Displays an SRC on the control panel using callout data. These functions are available in both normal and manual operating mode when an SRC is available.
20	Displays the machine type and model, VPD card CCIN, and IPL types. This function is available in both normal and manual operating mode.
21	For System i [®] models, it causes the Use Dedicated Service Tool (DST) display to appear on the system console. To exit the DST, select the Resume operating system display option. This function is available only in the manual operating mode and when activated by the IBM i operating system. Not applicable for System p [®] servers.
22	Forces a partition dump. For more information on dumps, see Performing dumps. This function is available only in the manual operating mode and when activated by the operating system.
23 - 24	Reserved.
25 - 26	Use service switches 1 and 2 to enable or disable functions 50 through 99. These functions are available only in the manual operating mode.
27 - 29	Reserved.
30	Displays the service processor IP address and port location. This function is available only in the manual operating mode and in standby. Note: If IPv6 is displayed, then the service processor's network ports are configured with IPv6 IP addresses. There are not enough characters on the control panel to display the entire address.
31 - 33	Reserved.
34	For System i models, it retries the partition dump. This function is available only in the manual operating mode and when activated by the IBM i operating system. Not applicable for System p servers.
35 - 41	Reserved.
42	Performs a platform dump. This function is available only in the manual operating mode and when activated by the operating system or the service processor.

Table 1. Primary and customer-extended control panel (32-character) function codes (continued)

Function code	Function selected
43	Performs a service processor dump. This function is available only in the manual operating mode.
44 - 54	Reserved.
55	Displays or changes the platform dump collection policy, platform dump hardware content, and platform dump firmware content settings. This function is available only in the manual operating mode.
56 - 62	Reserved.
63	Displays up to the last 25 system status SRCs. This function is available only in the manual operation mode.
64	Displays up to the last 25 diagnostic status SRCs. This function is available only in the manual operation mode.
65 - 70	Not applicable.
71 - 99	Reserved.

If you cannot find the function code in this chart, added features or devices might not have been available when this information was produced. Look on the control panel for supplemental unit function code information for the function code that you displayed.

Related tasks

“Putting the physical control panel in manual operating mode” on page 3

You must first put the physical control panel in manual operating mode before you can select or activate certain functions.

Primary control panel functions

The primary control panel functions, include displaying the selected IPL type, selecting the firmware mode, or restarting an IPL.

Function 01: Display selected IPL type, system operating mode, and IPL speed

This function allows you to display the current system operating mode, the IPL speed for the next IPL, the firmware mode for the next IPL, and the operating system IPL mode (when enabled).

This function is available in both normal and manual operating mode.

This function displays the following information:

- The operating system (OS) IPL types (A, B, C, or D).
- The valid logical key modes (M or N).
- The IPL speed (F, V=F, S, V=S, H, V=H, X, or V=X).
- The firmware mode (P or T).

Table 2. Function 01 on systems without OS IPL enabled

Function/Data	Action or description
0 1 _	Use the Increment or Decrement buttons to scroll to function 01.

Table 2. Function 01 on systems without OS IPL enabled (continued)

Function/Data	Action or description
0 1 _ _ A _ _ M _ _ V = F _ _ _ _ _ _ _ _ _ _ _ _ _ _ P _ _ _ _	Valid OS IPL types are A, B, C, and D. Valid system operating modes are M and N. Valid IPL speed displays are F, V=F, S, V=S, H, and V=H. Valid firmware IPL modes are P and T.
0 1 _	Use the Increment or Decrement buttons to scroll through the control panel functions.

Function 02: Select IPL type, IPL speed override, system operating mode, and firmware mode

This function allows you to select the IPL type and logical key mode when the system is either powered on or off.

This function is available in both normal and manual operating mode.

Before you can select the IPL speed, the system must be at power on standby.

For powered-on systems, function 02 is used to select the operating system (OS) IPL type, system operation mode, or firmware IPL mode. The following table shows an example of the function 02 IPL type, system operating mode, and firmware IPL mode selection sequence for a powered-on system.

Table 3. Function 02: Select IPL type, system operating mode, and firmware IPL mode on powered-on systems

Function/Data	Action or description
0 2 _	Use the Increment or Decrement buttons to scroll to function 02.
0 2 _ _ A < _ M _ _ _ _ _ _ _ _ _ _ _ _ _ _ _ _ P _ _ _ _	Press Enter to start function 02. <ul style="list-style-type: none"> The current OS IPL type is displayed with a pointer. The current system operating mode is displayed. The current firmware mode is displayed.
0 2 _ _ B < _ M _ _ _ _ _ _ _ _ _ _ _ _ _ _ _ _ P _ _ _ _	Use the Increment or Decrement buttons to scroll through the OS IPL types.
0 2 _ _ B _ _ M < _ _ _ _ _ _ _ _ _ _ _ _ _ _ _ _ P _ _ _ _	Press Enter to select the OS IPL type. <ul style="list-style-type: none"> The current OS IPL type is displayed. The current system operating mode is displayed with a pointer. The current firmware mode is displayed.
0 2 _ _ B _ _ N < _ _ _ _ _ _ _ _ _ _ _ _ _ _ _ _ P _ _ _ _	Use the Increment or Decrement buttons to scroll through the system operating modes.
0 2 _ _ B _ _ N _ _ _ _ _ _ _ _ _ _ _ _ _ _ _ _ P < _ _ _	Press Enter to select the system operating mode. <ul style="list-style-type: none"> The current OS IPL type is displayed. The current system operating mode is displayed. The current firmware mode is displayed with a pointer.
0 2 _ _ B _ _ N _ _ _ _ _ _ _ _ _ _ _ _ _ _ _ _ T < _ _ _	Use the Increment or Decrement buttons to scroll through the firmware IPL modes.

Table 3. Function 02: Select IPL type, system operating mode, and firmware IPL mode on powered-on systems (continued)

Function/Data	Action or description
0 2 _ _ _ _ _ _ _ _ _ _	Press Enter to select the firmware IPL mode and exit function 02.
0 1 _ _ _ _ _ _ _ _ _ _	Use the Increment or Decrement buttons to scroll through the control panel functions.

For powered-off systems, function 02 is used to select the OS IPL type, system operating mode, system IPL speed, and firmware IPL mode. The following table shows an example of the function 02 OS IPL type, system operating mode, system IPL speed, and firmware IPL mode selection sequence for a powered-off system.

Table 4. Function 02: Select IPL type, system operating mode, system IPL speed, and firmware IPL mode on powered-off systems

Function/Data	Action or description
0 2 _ _ _ _ _ _ _ _ _ _	Use the Increment or Decrement buttons to scroll to function 02.
0 2 _ _ A < _ M _ _ _ _ V _ _ _ _ _ _ _ _ _ T _ _ _ _	Press Enter to start function 02. <ul style="list-style-type: none"> The current OS IPL type is displayed with a pointer. The current system operating mode is displayed. The current IPL speed is displayed. The current firmware IPL mode is displayed.
0 2 _ _ B < _ M _ _ _ _ V _ _ _ _ _ _ _ _ _ T _ _ _ _	Use the Increment or Decrement buttons to scroll through the OS IPL types.
0 2 _ _ B _ _ M < _ _ _ V _ _ _ _ _ _ _ _ _ T _ _ _ _	Press Enter to select the IPL type. <ul style="list-style-type: none"> The current IPL type is displayed. The current system operating mode is displayed with a pointer. The current IPL speed is displayed. The current firmware IPL mode is displayed.
0 2 _ _ B _ _ N < _ _ _ V _ _ _ _ _ _ _ _ _ T _ _ _ _	Use the Increment or Decrement buttons to scroll through the system operating modes.
0 2 _ _ B _ _ N _ _ _ _ V < _ _ _ _ _ _ _ _ T _ _ _ _	Press Enter to select the system operating mode. <ul style="list-style-type: none"> The current IPL type is displayed. The current system operation mode is displayed. The current IPL speed is displayed with a pointer. The current firmware IPL mode is displayed.
0 2 _ _ B _ _ N _ _ _ _ S < _ _ _ _ _ _ _ _ T _ _ _ _	Use the Increment or Decrement buttons to scroll through the IPL speeds.
0 2 _ _ B _ _ N _ _ _ _ S _ _ _ _ _ _ _ _ _ T < _ _ _ _	Press Enter to select the IPL speed. <ul style="list-style-type: none"> The current IPL type is displayed. The current system operation mode is displayed. The current IPL speed is displayed. The current firmware IPL mode is displayed with a pointer.
0 2 _ _ B _ _ N _ _ _ _ S _ _ _ _ _ _ _ _ _ P < _ _ _ _	Use the Increment or Decrement buttons to scroll through the firmware IPL modes.

Table 4. Function 02: Select IPL type, system operating mode, system IPL speed, and firmware IPL mode on powered-off systems (continued)

Function/Data	Action or description
0 2 _	Press Enter to select the firmware IPL mode and exit function 02.
0 1 _	Use the Increment or Decrement buttons to scroll through the control panel functions.

Function 03: Restart IPL

This function restarts an IPL of the system using the selected IPL parameters.

This function is available only in manual operating mode and when the system power is on.

When you select function 03 and press Enter, a confirm action SRC (A1008003) is displayed. If you want to perform a restart IPL operation, select function 03 and press Enter again.

Notifications are not required prior to restarting the IPL.

Function 04: Lamp test

This function shows whether any of the control panel indicators are not working correctly, and whether characters that are displayed in the Function/Data display on the control panel are valid.

This function is available in both normal and manual operating mode.

When a lamp test is initiated, the firmware-controlled indicators in the central electronics complex (CEC) and the expansion units are turned on solid for 4 minutes, and then restored to their previous states.

Use the following procedure to verify that the lights on the system control panel are working correctly.

1. Power on the system.
2. Press the Increment (↑) or Decrement (↓) buttons on the control panel to display function 04.
Press Enter on the control panel.
3. Do all of the lights and indicators on the system control panel come on?

Yes	No
↓	Exchange the FRU with the faulty LED indicator. For example, replace the fan if the LED on a fan does not turn on.

4. Do the expansion unit control panel lights all come on?

Note: The expansion unit control panel lights will be lit for only about 25 seconds after function 04 is entered.

Yes	No
The lights on the system control panel are working correctly.	Exchange the control panel on the expansion unit.

Functions 05 - 06: Reserved

This function is reserved.

Function 07: SPCN functions

This function allows you to perform a system power control network (SPCN) operation.

This function is available only in the manual operating mode and from power on standby.

Notes:

- The system that will display the ID must be powered off with ac power applied.
- If you have just restored power to the system, the service processor must return to standby mode before the control panel functions will work correctly. Returning the service processor to standby mode takes a few minutes *after* the panel appears to be operational.
- The control panel must be in manual operating mode to access function 07 options.

To perform an SPCN operation that is controlled by function 07, do the following:

1. Select function 07, and then press Enter. 07** is displayed.
2. Select the function that you want to perform (see Table 5). Use the Increment or Decrement buttons (↑↓) to scroll to the appropriate function. Press Enter to display 07nn00, where nn is the function that you selected.

Table 5. SPCN functions in function 07

Function	Description	For more information
A1	Broadcasts a power-on command.	Go to step 5.
A6	Displays frame address on all I/O enclosures.	Go to step 5.
A8	Displays the SPCN configuration ID number for a selected frame.	07A8 is displayed. Go to step 3.
A9	Sets the SPCN configuration ID for a selected frame.	07A9 is displayed. Go to step 4.

3. If you selected function A8 in step 2, complete the following steps to display the configuration of the I/O enclosure:
 - a. Use the Increment (↑) or Decrement (↓) buttons to select the first two characters of the frame address of the I/O enclosure, and then press Enter. 07nn00 is displayed, where nn is the first byte of the frame address.
 - b. Use the Increment (↑) or Decrement (↓) buttons to select the second two characters of the frame address of the I/O enclosure, and then press Enter. 07nn00 is displayed on the selected I/O enclosure, where nn is the second byte of the frame address.

Notes:

- The display on the addressed I/O enclosure is blinking on and off.
 - The configuration ID is the last two characters of the bottom line.
4. If you selected function A9 in step 2, complete the following steps to set the configuration of the selected I/O enclosure:
 - a. Ensure that the system power of the selected I/O enclosure is in standby mode. If the system power of the selected I/O enclosure is not in standby mode, power it off. Then return to step 1.
 - b. Use the (↑) or Decrement (↓) buttons to select the first two characters of the frame address of the I/O enclosure to configure, and then press Enter. 07nn00 is displayed, where nn is the first byte of the unit address.
 - c. Use the Increment (↑) or Decrement (↓) buttons to select the second two characters of the frame address of the I/O enclosure, and then press Enter. 07nn00 is displayed, where nn is the second byte of the frame address.

Note: The display on the addressed I/O enclosure is blinking on and off.

- d. Use the Increment (↑) or Decrement (↓) buttons to select the correct configuration ID. *07nn* is displayed, where *nn* is the configuration ID.
 - e. Press Enter. *07nn00* is displayed. After 20 to 30 seconds, the display on the addressed I/O enclosure stops blinking and returns to the normal display format.
5. Scroll to *07*** using the Increment (↑) or Decrement (↓) buttons, and then press Enter. This returns the control panel to the normal display.

Function 08: Fast power off

This function allows you to power off the system when it is suspended. This function is available only when the system is in manual operating mode and the system power is on.

When you select function 08 and press Enter, a confirm action SRC (A1008008) is displayed. If you want to perform a fast power off (FPO) operation, select function 08 and press Enter again. After the fast power off, the system returns to its default display.

Attention: Because of the potential for causing a loss of data, do not use this function if you can shut down the system from the operating system.

Note: If you changed the system password at the most recent IPL, performing a fast power off might cause that new password information to be lost.

Functions 09 - 10: Reserved

These functions are reserved.

Function 11: SRC display (ASCII string)

This function displays a system reference code (SRC) on the control panel using up to 32 ASCII characters, including nonhexadecimal characters, and can be displayed in all display positions. This function serves as a diagnostic aid that helps you determine the source of a hardware or operating system problem.

This function is the default SRC display and is available in both normal and manual operating mode when an SRC is available.

Function 11, if enabled, represents the words of the SRC.

Record SRC information for error reporting. For more information, see *Using the control panel to collect reference codes and system information*.

Related information

Using the control panel to collect reference codes and system information

Function 12: SRC display (hex words 2 - 5)

This function displays a system reference code (SRC) on the control panel to serve as a diagnostic aid that helps you determine the source of a hardware or operating system problem.

This function is available in both normal and manual operating mode when an SRC is available.

The extended SRC data words are displayed depending on the number in the SRC. Extended SRC data words are displayed four words at a time. If any extended SRC data words exist, function 12 is scrollable. Unused words are presented as blanks in the required display.

Record SRC information for error reporting. For more information, see *Using the control panel to collect reference codes and system information*.

Function 13: SRC display (hex words 6 - 9)

This function displays a system reference code (SRC) on the control panel to serve as a diagnostic aid that helps you determine the source of a hardware or operating system problem.

This function is available in both normal and manual operating mode when an SRC is available.

The extended SRC data words are displayed depending on the number in the SRC. Extended SRC data words are displayed four words at a time. If there are only one to four extended SRC data words, function 13 is not scrollable. If there are five to eight extended SRC data words, function 13 is scrollable. Unused words are presented as blanks in the required display.

Record SRC information for error reporting. For more information, see Using the control panel to collect reference codes and system information..

Related information

Using the control panel to collect reference codes and system information

Functions 14 - 19: SRC display (callouts)

These functions display a system reference code (SRC) on the control panel to serve as a diagnostic aid to help you determine the source of a hardware or operating system problem.

These functions are available in both normal and manual operating mode when an SRC is available.

Functions 14 - 19, if enabled, display field replaceable unit (FRU) and procedure callout data. This data is displayed following any present extended SRC data words. Multiple FRU and procedure callout data entries can be included with each SRC. One FRU or procedure callout data entry is displayed for each function number. Up to six different FRU or procedure callout data entries can be presented at the control panel using functions 14 - 19.

The following table shows an example of a function 14 FRU callout display selection sequence.

Table 6. Function 14: FRU callout display selection sequence

Function/Data	Action or description
1 4 _	Use the Increment or Decrement buttons to scroll to function 14.
H_ -PARTNUM_ CCIN_ _ U970305010ABCDE- _ _ _	Press Enter to select function 14. The FRU callout data is displayed.
1 4 _	Pressing Enter toggles between function and data display.

The following table shows an example of a function 15 procedure callout display selection sequence.

Table 7. Function 15: Procedure callout display selection sequence

Function/Data	Action or description
1 5 _	Use the Increment or Decrement buttons to scroll to function 15.
M_ -FSPSP04_ _ _ _ _ _ _ _ _ _ _ _ _ _ _ _ _ _	Press Enter to select function 15. The procedure callout data is displayed.
1 5 _	Pressing Enter toggles between function and data display.

Record SRC information for error reporting.

Related information

Using the control panel to collect reference codes and system information

Function 20: System type, model, feature code, and IPL type

This function displays the machine type and model, the custom card identification number (CCIN) for the vital product data (VPD) card, and IPL types. This function is available in both normal and manual operating mode.

The machine type, model, CCIN for the VPD card, and IPL type are displayed in the following format:

```
p p p p - m m m _ _ _ c c c c  
T T T T T T T t t t t t t t
```

The values are indicated as follows:

- Values for *p* indicate the machine type.
- Values for *m* indicate the machine model.
- Values for *c* indicate the system CCIN for the VPD card.
- Values for *T* indicate the CEC IPL type.
- Values for *t* indicate the FSP IPL type.

Record this information with the system reference code (SRC).

If you select this function and it has not been activated, the command is rejected.

Customer-extended panel functions

The customer-extended panel functions include partition dumps, service processor IP address and port location.

Function 21: Service tool initiation

For System i models, this function makes dedicated service tools (DST) available on the system console display. For System p servers, it is not applicable.

This function is available only in the manual operating mode and when activated by the operating system.

The Use dedicated service tools (DST) display is available on the primary or alternative console.

To exit the DST and return to the operating system, select the **Resume operating system display** option on the Use dedicated service tools (DST) display.

Function 22: Partition dump

This function initiates a dump of the operating system data in a logical partition.

This function is available only in the manual operating mode and when activated by the operating system.

You must perform two consecutive function 22 selections to initiate a partition dump. The following table shows an example of function 22.

Table 8. Function 22: Initiate a partition dump

Function/Data	Action or description
2 2 _	Use the Increment or Decrement buttons to scroll to function 22.
2 2 _ _ _ _ 0 0 _ _ _ _ _ _ _ _ _ _ _ _ _ _ _	Press Enter to start function 22.
A 1 0 0 3 0 2 2 _ _ _ _ _ _ _ _ _ _ _ _ _ _ _	Displays the partition dump verification system reference code (SRC).
2 2 _	Use the Increment or Decrement buttons to scroll to function 22.
2 2 _ _ _ _ 0 0 _ _ _ _ _ _ _ _ _ _ _ _ _ _ _	Press Enter to start function 22.

Functions 23 - 24: Reserved

These functions are reserved.

Functions 25 - 26: Service switches 1 and 2

These functions are used to set the service function range (50 to 99). These functions are available only in the manual operating mode.

To set the service function range (50 to 99), use function 25 to set the service representative switch 1, and then use function 26 to set the service representative switch 2.

Functions 27 - 29: Reserved

These functions are reserved.

Function 30: Service processor IP address and port location

This function displays the service processor IP address and port location. This function is available only in the manual operating mode and from power on standby.

Note: If IPv6 is displayed on the control panel, then the service processor's network ports are configured with IPv6 IP addresses. There are not enough characters on the control panel to display the entire address.

The following table shows an example of function 30.

Table 9. Function 30: Service processor IP address and port location

Function/Data	Action or description
3 0 _	Use the Increment or Decrement buttons to scroll to function 30.
3 0 * * _ _ _ _ _ _ _ _ _ _ _ _ _ _ _ _ _ _	Press Enter to enter subfunction mode.
3 0 0 0 _ _ _ _ _ _ _ _ _ _ _ _ _ _ _ _ _ _	Use the Increment or Decrement buttons to select an IP address 00 = SP A: ETH0 (primary enclosure) 01 = SP A: ETH1 (primary enclosure) 02 = SP B: ETH0 (secondary enclosure) 03 = SP B: ETH1 (secondary enclosure)

Table 9. Function 30: Service processor IP address and port location (continued)

Function/Data	Action or description
S P _ A : _ E T H O : _ _ _ T 5 9 . 5 . 1 0 5 . 2 4 3 _ _ _ _ _	Press Enter to display the selected IP address.
3 0 * * _	Use the Increment or Decrement buttons to select subfunction exit.
3 0 _	Press Enter to exit subfunction mode.

Functions 31 - 33: Reserved

These functions are reserved.

Function 34: Retry partition dump

Not applicable.

Functions 35 - 41: Reserved

These functions are reserved.

Function 42: Platform dump

This function initiates a platform dump. This function is available only in the manual operating mode and when activated by the operating system or the service processor.

You can use function 42 to dump IBM POWER® Hypervisor™ main storage and hardware data. You must perform two consecutive function 42 selections to initiate a platform dump. The following table shows an example of function 42.

Table 10. Function 42: Initiate a platform dump

Function/Data	Action or description
4 2 _	Use the Increment or Decrement buttons to scroll to function 42.
4 2 _ _ _ _ 0 0 _	Press Enter to start function 42.
A 1 0 0 3 0 4 2 _	Displays the confirmation SRC.
4 2 _	Use the Increment or Decrement buttons to scroll to function 42.
4 2 _ _ _ _ 0 0 _	Press Enter to start function 42.

Function 43: Service processor dump

This function initiates a service processor dump. This function is available only in the manual operating mode.

You must perform two consecutive function 43 selections to initiate a service processor dump. The following table shows an example of function 43.

Table 11. Function 43: Initiate a service processor dump

Function/Data	Action or description
4 3 _	Use the Increment or Decrement buttons to scroll to function 43.
4 3 0 0 _ _ _ _ _ _ _ _ _ _ _ _ _ _ _ _ _ _	Press Enter to confirm.
A 1 0 0 3 0 4 3 _ _ _ _ _ _ _ _ _ _ _ _ _ _ _	Displays the confirmation system reference code (SRC).
4 3 _	Use the Increment or Decrement buttons to scroll to function 43.
4 3 0 0 _ _ _ _ _ _ _ _ _ _ _ _ _ _ _ _ _ _	Press Enter to confirm.

Functions 44 - 54: Reserved

These functions are reserved.

Function 55: View and change platform dump data

This function allows you to view and change the platform dump data. This function is available only in the manual operating mode.

When you select function 55 and press Enter, you can view and change the platform dump collection policy, platform dump hardware content, and platform dump firmware content settings.

The following table shows an example of how to view the platform dump data.

Table 12. Function 55: View the platform dump data

Function/Data	Action or description
5 5 _	Use the Increment or Decrement buttons to scroll to function 55.
5 5 * * _ _ _ _ _ _ _ _ _ _ _ _ _ _ _ _ _ _	Press Enter to enter subfunction mode.
5 5 0 0 _ _ _ _ _ _ _ _ _ _ _ _ _ _ _ _ _ _	Use the Increment or Decrement buttons to view the platform dump variables.
5 5 0 0 _ xxyyzz _ _ _ _ _ _ _ _ _ _ _ _ _ _ _	Press Enter to process the selected subfunction. xx = Collection policy yy = Hardware content zz = Firmware content
5 5 * * _ _ _ _ _ _ _ _ _ _ _ _ _ _ _ _ _ _	Use the Increment or Decrement buttons to select subfunction exit.
5 5 _	Press Enter to exit subfunction mode.

The following table shows an example of how to change the platform dump data.

Table 13. Function 55: Change the platform dump data

Function/Data	Action or description
5 5 _	Use the Increment or Decrement buttons to scroll to function 55.

Table 13. Function 55: Change the platform dump data (continued)

Function/Data	Action or description
5 5 * * _	Press Enter to enter subfunction mode.
5 5 0 2 _	Use the Increment or Decrement buttons to select to change the platform dump variable. 01 = Set platform dump collection policy to <i>disable</i> 02 = Set platform dump collection policy to <i>enable</i> 03 = N/A - will always display FF in Line 1 when selected 04 = Set platform dump hardware content to <i>maximum</i> 05 = Set platform dump hardware content to <i>automatic</i> 06 = N/A - will always display FF in Line 1 when selected 07 = N/A - will always display FF in Line 1 when selected 08 = Set platform dump firmware content to <i>minimum</i> 09 = Set platform dump firmware content to <i>maximum</i> 0A = Set platform dump firmware content to <i>physical I/O</i> 0B = Set platform dump firmware content to <i>virtual I/O</i> 0C = Set platform dump firmware content to <i>HPS cluster</i> 0D = Set platform dump firmware content to <i>InfiniBand I/O</i>
5 5 0 2 _ 0 0 _ _ _ _ _ _ _ _ _ _ _ _ _ _ _ _ _ _	Press Enter to process the selected subfunction. 00 = Accept FF = Reject
5 5 * * _	Use the Increment or Decrement buttons to select subfunction exit.
5 5 _	Press Enter to exit subfunction mode.

Functions 56 - 62: Reserved

These functions are reserved.

Function 63: Display system status SRCs

When you select function 63 and press Enter, you can display up to the last 25 system status SRCs. This function is available only in the manual operating mode.

The following table shows an example of how to display the last 25 system status SRCs.

Table 14. Function 63: Display system status SRCs

Function/Data	Action or description
6 3 _	Use the Increment or Decrement buttons to scroll to function 63.
6 3 * * _	Press Enter to enter subfunction mode.

Table 14. Function 63: Display system status SRCs (continued)

Function/Data	Action or description
6 3 1 8 _ _ _ _ _ _ _ _ _ _	Use the Increment or Decrement buttons to select the address offset. Note: Enter a subfunction between 00 and 18 to view the SRCs in sequential order. The most recent SRC displays at the highest possible subfunction number (18). If no system status SRCs exist, then only subfunction 00 is available and it will not display an SRC when selected.
C 1 0 0 1 0 3 4 _ _ _ _ _ _ _ _ _ _	Press Enter to read the SRC data.
6 3 * * _ _ _ _ _ _ _ _ _ _	Use the Increment or Decrement buttons to select subfunction exit.
6 3 _ _ _ _ _ _ _ _ _ _	Press Enter to exit subfunction mode.

Function 64: Display diagnostic status SRCs

When you select function 64 and press Enter, you can display up to the last 25 diagnostic status SRCs. This function is available only in the manual operating mode.

The following table shows an example of how to display the diagnostic status SRCs.

Table 15. Function 63: Display diagnostic status SRCs

Function/Data	Action or description
6 4 _ _ _ _ _ _ _ _ _ _	Use the Increment or Decrement buttons to scroll to function 64.
6 4 * * _ _ _ _ _ _ _ _ _ _	Press Enter to enter subfunction mode.
6 4 0 2 _ _ _ _ _ _ _ _ _ _	Use the Increment or Decrement buttons to select the address offset. Note: Enter a subfunction between 00 and 18 to view the SRCs in sequential order. The most recent SRC displays at the highest possible subfunction number (18). If no diagnostic status SRCs exist, then only subfunction 00 is available and it will not display an SRC when selected.
D 1 2 3 4 5 6 7 _ _ _ _ _ _ _ _ _ _	Press Enter to read the SRC data.
6 4 * * _ _ _ _ _ _ _ _ _ _	Use the Increment or Decrement buttons to select subfunction exit.
6 4 _ _ _ _ _ _ _ _ _ _	Press Enter to exit subfunction mode.

Functions 65 - 70: Not applicable

These functions are not applicable.

Functions 71 - 99: Reserved

These functions are reserved.

Values for IPL types, system operating modes, and speeds

Learn about the valid initial program load (IPL) types, system operating modes, IPL speeds, and firmware IPL types that are used in control panel functions.

The following table shows examples of the IPL types and descriptions.

Note: Operating system IPL types are displayed only when the operating system IPL mode has been enabled from the operating system.

Table 16. Operating system IPL types

Initial program load (IPL) type	Action or description
A	IPL from disk using copy A of the system Licensed Internal Code.
B	IPL from disk using copy B of the system Licensed Internal Code.
C	Reserved for hardware service use only. Attention: Incorrect use of this function can cause severe data loss.
D	IPL from media other than load-source disk. Alternate IPL for code installation support.

The following table shows examples of the operating mode values.

Table 17. System operating mode values

System operating mode	Action or description
Manual (M)	Allows you to perform an attended IPL and provides access to restricted control panel functions.
Normal (N)	Allows you to perform an unattended IPL.

The following table shows examples of the IPL speeds.

Table 18. IPL speeds

IPL speed	Action or description	Details
F	Fast override for one IPL.	Fast IPL runs. Some hardware diagnostics are passed over.
S	Slow override for one IPL.	Full hardware diagnostics runs. Use this speed whenever hardware is changed, for intermittent hardware failure, or on the first installation IPL. The following diagnostics are run: <ul style="list-style-type: none">• Main storage tests.• Service processor inter-chip interface tests (wire test).• Extended logical built-in self tests.
V=F	Use system-defined speed.	Fast IPL set by the system value (displayed at function 01).
V=S	Use system-defined speed.	Slow IPL set by the system value (displayed at function 01).
V	Fast IPL or slow IPL set by the system value (selected at function 02).	Function 02 selection, or the system default at each IPL.

Table 18. IPL speeds (continued)

IPL speed	Action or description	Details
H	Hyperboot override for one IPL.	Hyperboot IPL runs. Most hardware diagnostics are skipped and the system's cached data is used unless new VPD is discovered.
V=H	Use system-defined speed.	Hyperboot IPL is set by the system value (displayed at function 01).

The following table shows examples of firmware IPL types.

Table 19. Firmware IPL types

IPL type	Action or description
P	IPL from disk using copy P of the system Licensed Internal Code.
T	IPL from disk using copy T of the system Licensed Internal Code.

Appendix. Notices

This information was developed for products and services offered in the U.S.A.

The manufacturer may not offer the products, services, or features discussed in this document in other countries. Consult the manufacturer's representative for information on the products and services currently available in your area. Any reference to the manufacturer's product, program, or service is not intended to state or imply that only that product, program, or service may be used. Any functionally equivalent product, program, or service that does not infringe any intellectual property right of the manufacturer may be used instead. However, it is the user's responsibility to evaluate and verify the operation of any product, program, or service.

The manufacturer may have patents or pending patent applications covering subject matter described in this document. The furnishing of this document does not grant you any license to these patents. You can send license inquiries, in writing, to the manufacturer.

The following paragraph does not apply to the United Kingdom or any other country where such provisions are inconsistent with local law: THIS INFORMATION IS PROVIDED "AS IS" WITHOUT WARRANTY OF ANY KIND, EITHER EXPRESS OR IMPLIED, INCLUDING, BUT NOT LIMITED TO, THE IMPLIED WARRANTIES OF NON-INFRINGEMENT, MERCHANTABILITY OR FITNESS FOR A PARTICULAR PURPOSE. Some states do not allow disclaimer of express or implied warranties in certain transactions, therefore, this statement may not apply to you.

This information could include technical inaccuracies or typographical errors. Changes are periodically made to the information herein; these changes will be incorporated in new editions of the publication. The manufacturer may make improvements and/or changes in the product(s) and/or the program(s) described in this publication at any time without notice.

Any references in this information to Web sites not owned by the manufacturer are provided for convenience only and do not in any manner serve as an endorsement of those Web sites. The materials at those Web sites are not part of the materials for this product and use of those Web sites is at your own risk.

The manufacturer may use or distribute any of the information you supply in any way it believes appropriate without incurring any obligation to you.

Any performance data contained herein was determined in a controlled environment. Therefore, the results obtained in other operating environments may vary significantly. Some measurements may have been made on development-level systems and there is no guarantee that these measurements will be the same on generally available systems. Furthermore, some measurements may have been estimated through extrapolation. Actual results may vary. Users of this document should verify the applicable data for their specific environment.

Information concerning products not produced by this manufacturer was obtained from the suppliers of those products, their published announcements or other publicly available sources. This manufacturer has not tested those products and cannot confirm the accuracy of performance, compatibility or any other claims related to products not produced by this manufacturer. Questions on the capabilities of products not produced by this manufacturer should be addressed to the suppliers of those products.

All statements regarding the manufacturer's future direction or intent are subject to change or withdrawal without notice, and represent goals and objectives only.

The manufacturer's prices shown are the manufacturer's suggested retail prices, are current and are subject to change without notice. Dealer prices may vary.

This information is for planning purposes only. The information herein is subject to change before the products described become available.

This information contains examples of data and reports used in daily business operations. To illustrate them as completely as possible, the examples include the names of individuals, companies, brands, and products. All of these names are fictitious and any similarity to the names and addresses used by an actual business enterprise is entirely coincidental.

If you are viewing this information in softcopy, the photographs and color illustrations may not appear.

The drawings and specifications contained herein shall not be reproduced in whole or in part without the written permission of the manufacturer.

The manufacturer has prepared this information for use with the specific machines indicated. The manufacturer makes no representations that it is suitable for any other purpose.

The manufacturer's computer systems contain mechanisms designed to reduce the possibility of undetected data corruption or loss. This risk, however, cannot be eliminated. Users who experience unplanned outages, system failures, power fluctuations or outages, or component failures must verify the accuracy of operations performed and data saved or transmitted by the system at or near the time of the outage or failure. In addition, users must establish procedures to ensure that there is independent data verification before relying on such data in sensitive or critical operations. Users should periodically check the manufacturer's support websites for updated information and fixes applicable to the system and related software.

Trademarks

IBM, the IBM logo, and ibm.com are trademarks or registered trademarks of International Business Machines Corp., registered in many jurisdictions worldwide. Other product and service names might be trademarks of IBM or other companies. A current list of IBM trademarks is available on the Web at Copyright and trademark information at www.ibm.com/legal/copytrade.shtml.

INFINIBAND, InfiniBand Trade Association, and the INFINIBAND design marks are trademarks and/or service marks of the INFINIBAND Trade Association.

Other company, product, or service names may be trademarks or service marks of others.

Electronic emission notices

Class A Notices

The following Class A statements apply to the IBM servers that contain the POWER6 processor.

Federal Communications Commission (FCC) statement

Note: This equipment has been tested and found to comply with the limits for a Class A digital device, pursuant to Part 15 of the FCC Rules. These limits are designed to provide reasonable protection against harmful interference when the equipment is operated in a commercial environment. This equipment generates, uses, and can radiate radio frequency energy and, if not installed and used in accordance with the instruction manual, may cause harmful interference to radio communications. Operation of this equipment in a residential area is likely to cause harmful interference, in which case the user will be required to correct the interference at his own expense.

Properly shielded and grounded cables and connectors must be used in order to meet FCC emission limits. IBM is not responsible for any radio or television interference caused by using other than recommended cables and connectors or by unauthorized changes or modifications to this equipment. Unauthorized changes or modifications could void the user's authority to operate the equipment.

This device complies with Part 15 of the FCC rules. Operation is subject to the following two conditions: (1) this device may not cause harmful interference, and (2) this device must accept any interference received, including interference that may cause undesired operation.

Industry Canada Compliance Statement

This Class A digital apparatus complies with Canadian ICES-003.

Avis de conformité à la réglementation d'Industrie Canada

Cet appareil numérique de la classe A respecte est conforme à la norme NMB-003 du Canada.

European Community Compliance Statement

This product is in conformity with the protection requirements of EU Council Directive 2004/108/EC on the approximation of the laws of the Member States relating to electromagnetic compatibility. IBM cannot accept responsibility for any failure to satisfy the protection requirements resulting from a non-recommended modification of the product, including the fitting of non-IBM option cards.

This product has been tested and found to comply with the limits for Class A Information Technology Equipment according to European Standard EN 55022. The limits for Class A equipment were derived for commercial and industrial environments to provide reasonable protection against interference with licensed communication equipment.

European Community contact:
IBM Technical Regulations
Pascalstr. 100, Stuttgart, Germany 70569
Tele: 0049 (0)711 785 1176
Fax: 0049 (0)711 785 1283
E-mail: tjahn@de.ibm.com

Warning: This is a Class A product. In a domestic environment, this product may cause radio interference, in which case the user may be required to take adequate measures.

VCCI Statement - Japan

この装置は、クラスA情報技術装置です。この装置を家庭環境で使用すると電波妨害を引き起こすことがあります。この場合には使用者が適切な対策を講ずるよう要求されることがあります。

VCCI-A

The following is a summary of the VCCI Japanese statement in the box above:

This is a Class A product based on the standard of the VCCI Council. If this equipment is used in a domestic environment, radio interference may occur, in which case, the user may be required to take corrective actions.

**Japanese Electronics and Information Technology Industries Association (JEITA)
Confirmed Harmonics Guideline (products less than or equal to 20 A per phase)**

高調波ガイドライン適合品

**Japanese Electronics and Information Technology Industries Association (JEITA)
Confirmed Harmonics Guideline with Modifications (products greater than 20 A per phase)**

高調波ガイドライン準用品

Electromagnetic Interference (EMI) Statement - People's Republic of China

声 明

此为 A 级产品,在生活环境
中,该产品可能会造成无线电干
扰。在这种情况下,可能需要用
户对其干扰采取切实可行的措
施。

Declaration: This is a Class A product. In a domestic environment this product may cause radio interference in which case the user may need to perform practical action.

Electromagnetic Interference (EMI) Statement - Taiwan

警告使用者：

這是甲類的資訊產品，在居住的環境中使用時，可能會造成射頻干擾，在這種情況下，使用者會被要求採取某些適當的對策。

The following is a summary of the EMI Taiwan statement above.

Warning: This is a Class A product. In a domestic environment this product may cause radio interference in which case the user will be required to take adequate measures.

IBM Taiwan Contact Information:

台灣IBM 產品服務聯絡方式：
台灣國際商業機器股份有限公司
台北市松仁路7號3樓
電話：0800-016-888

Electromagnetic Interference (EMI) Statement - Korea

이 기기는 업무용으로 전자파적합등록을 한 기기이오니 판매자 또는 사용자는 이점을 주의하시기 바라며, 만약 잘못 판매 또는 구입하였을 때에는 가정용으로 교환하시기 바랍니다.

Please note that this equipment has obtained EMC registration for commercial use. In the event that it has been mistakenly sold or purchased, please exchange it for equipment certified for home use.

Germany Compliance Statement

Deutschsprachiger EU Hinweis: Hinweis für Geräte der Klasse A EU-Richtlinie zur Elektromagnetischen Verträglichkeit

Dieses Produkt entspricht den Schutzanforderungen der EU-Richtlinie 2004/108/EG zur Angleichung der Rechtsvorschriften über die elektromagnetische Verträglichkeit in den EU-Mitgliedsstaaten und hält die Grenzwerte der EN 55022 Klasse A ein.

Um dieses sicherzustellen, sind die Geräte wie in den Handbüchern beschrieben zu installieren und zu betreiben. Des Weiteren dürfen auch nur von der IBM empfohlene Kabel angeschlossen werden. IBM übernimmt keine Verantwortung für die Einhaltung der Schutzanforderungen, wenn das Produkt ohne Zustimmung der IBM verändert bzw. wenn Erweiterungskomponenten von Fremdherstellern ohne Empfehlung der IBM gesteckt/eingebaut werden.

EN 55022 Klasse A Geräte müssen mit folgendem Warnhinweis versehen werden:

"Warnung: Dieses ist eine Einrichtung der Klasse A. Diese Einrichtung kann im Wohnbereich Funk-Störungen verursachen; in diesem Fall kann vom Betreiber verlangt werden, angemessene Maßnahmen zu ergreifen und dafür aufzukommen."

Deutschland: Einhaltung des Gesetzes über die elektromagnetische Verträglichkeit von Geräten

Dieses Produkt entspricht dem "Gesetz über die elektromagnetische Verträglichkeit von Geräten (EMVG)". Dies ist die Umsetzung der EU-Richtlinie 2004/108/EG in der Bundesrepublik Deutschland.

Zulassungsbescheinigung laut dem Deutschen Gesetz über die elektromagnetische Verträglichkeit von Geräten (EMVG) (bzw. der EMC EG Richtlinie 2004/108/EG) für Geräte der Klasse A.

Dieses Gerät ist berechtigt, in Übereinstimmung mit dem Deutschen EMVG das EG-Konformitätszeichen - CE - zu führen.

Verantwortlich für die Konformitätserklärung nach des EMVG ist die IBM Deutschland GmbH, 70548 Stuttgart.

Generelle Informationen:

Das Gerät erfüllt die Schutzanforderungen nach EN 55024 und EN 55022 Klasse A.

Electromagnetic Interference (EMI) Statement - Russia

ВНИМАНИЕ! Настоящее изделие относится к классу А.
В жилых помещениях оно может создавать радиопомехи, для снижения которых необходимы дополнительные меры

Terms and conditions

Permissions for the use of these publications is granted subject to the following terms and conditions.

Personal Use: You may reproduce these publications for your personal, noncommercial use provided that all proprietary notices are preserved. You may not distribute, display or make derivative works of these publications, or any portion thereof, without the express consent of the manufacturer.

Commercial Use: You may reproduce, distribute and display these publications solely within your enterprise provided that all proprietary notices are preserved. You may not make derivative works of these publications, or reproduce, distribute or display these publications or any portion thereof outside your enterprise, without the express consent of the manufacturer.

Except as expressly granted in this permission, no other permissions, licenses or rights are granted, either express or implied, to the publications or any data, software or other intellectual property contained therein.

The manufacturer reserves the right to withdraw the permissions granted herein whenever, in its discretion, the use of the publications is detrimental to its interest or, as determined by the manufacturer, the above instructions are not being properly followed.

You may not download, export or re-export this information except in full compliance with all applicable laws and regulations, including all United States export laws and regulations.

THE MANUFACTURER MAKES NO GUARANTEE ABOUT THE CONTENT OF THESE PUBLICATIONS. THESE PUBLICATIONS ARE PROVIDED "AS-IS" AND WITHOUT WARRANTY OF ANY KIND, EITHER EXPRESSED OR IMPLIED, INCLUDING BUT NOT LIMITED TO IMPLIED WARRANTIES OF MERCHANTABILITY, NON-INFRINGEMENT, AND FITNESS FOR A PARTICULAR PURPOSE.



Printed in USA